

# Lenovo ThinkAgile SX for Microsoft Azure Stack (SXM4200, SXM6200) Product Guide (withdrawn product)

Lenovo ThinkAgile SX for Microsoft Azure Stack delivers a pre-integrated, easy-to-deploy rack-level solution for hybrid clouds to dramatically reduce time-to-value and total cost of ownership (TCO). The solution is based on Lenovo industry-leading data center infrastructure and Microsoft Azure Stack, an extension of Microsoft Azure Services to on-premises environments.

Suggested workloads for the ThinkAgile SX for Microsoft Azure Stack include virtual desktop infrastructure (VDI), back-office applications, server consolidation, enterprise applications, databases, test and development environments, and cloud implementation. Starting with as few as four nodes to keep your acquisition costs down, the solution offers “pay as you grow” scalability as your needs grow.

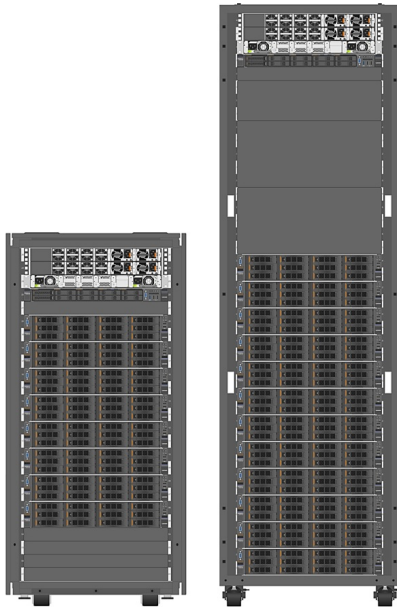

Figure 1. Lenovo ThinkAgile SX for Microsoft Azure Stack: 25U (left) or 42U (right) rack cabinet

## Did you know?

The ThinkAgile SX for Microsoft Azure Stack ships fully integrated into a rack cabinet, tested, configured, and ready to be plugged in and turned on; they are designed to integrate into an existing infrastructure effortlessly, to dramatically accelerate time to value and reduce infrastructure maintenance costs.

There is no up-front cloud software license acquisition cost for the ThinkAgile SX for Microsoft Azure Stack, monthly billing is based on the actual resource usage (capacity-based licenses are also available).

Lenovo provides ThinkAgile Advantage Single Point of Support for the entire ThinkAgile solution with the nodes, networking, and software, for quicker problem determination and minimized downtime.

## Key features

Lenovo ThinkAgile SX for Microsoft Azure Stack integrates computing, storage, networking, and management, and it is designed with industry-standard building blocks, including hyperconverged nodes that are built on powerful and highly reliable Lenovo servers, RackSwitch networking, and Azure Stack software that extends Azure technologies on-premises.

The ThinkAgile SX for Microsoft Azure Stack includes the ThinkAgile SXM4200 25U model that can be scaled from 4 to 8 nodes, the ThinkAgile SXM4200 42U model that can be scaled from 4 to 12 nodes, and the ThinkAgile SXM6200 model that ships with 12 nodes.

ThinkAgile SX for Microsoft Azure Stack offers the following key features:

- Scalable ThinkAgile SX for Microsoft Azure Stack configurations of an on-premises hyperconverged hybrid cloud platform designed to optimize workload's performance and provide the IT agility for business demands.
- Flexible monthly billing that is based on actual resource usage helps lower acquisition cost for the entire solution by eliminating upfront cloud software licensing fees.
- Factory-integrated, pre-configured ready-to-go solutions that are delivered in a rack cabinet with all the hardware customers need for their workloads: servers, storage, and network switches, plus Azure Stack cloud software and Lenovo XClarity hardware management tools.
- Designed for effortless integration into existing infrastructures, thereby reducing deployment time and saving money.
- Lenovo deployment services that are included with the solution help get customers up and running quickly.
- Proven and reliable Lenovo System x servers featuring Intel Xeon processor E5-2600 v4 product family provide compute power for a variety of workloads and applications.
- Lenovo RackSwitch switches deliver exceptional performance and low latency, along with cost savings, and are designed to perform seamlessly with other vendors' upstream switches.
- Microsoft Azure Stack provides a scalable, highly available solution for hybrid cloud extension to deliver Microsoft Azure cloud services on-premises with integrated compute, networking, storage, security, and management services that manage VM lifecycle and automate and orchestrate workload provisioning.
- Microsoft Storage Spaces Direct (S2D), an integrated part of the Azure Stack solution, delivers scalable, highly available distributed shared storage that provides extensive data protection and recovery with no performance bottlenecks and no single point of failure.
- Powerful tools to manage both hardware and applications that come with the ThinkAgile SX for Microsoft Azure Stack simplify and automate the management of the entire cloud solution, allowing customers to manage the infrastructure as a single system, rather than as individual components.
- Lenovo ThinkAgile Advantage provides a single point of contact for all support issues that customers might encounter with the server, networking, storage, and software used in the solution, for quicker problem determination and minimized downtime.

## Components

The ThinkAgile SX for Microsoft Azure Stack consists of the following hardware components:

- One System x3550 M5 management node.
- From 4 to 8 (SXM4200 25U), or from 4 to 12 (SXM4200 42U), or 12 (SXM6200) System x3650 M5 hyperconverged nodes.
- One RackSwitch G8052 1 GbE management network switch.
- Two RackSwitch G8272 10 GbE VM/storage network switches.

The System x3550 M5 management node provides hardware management services and includes the following software components:

- Windows Server 2016 Standard with Hyper-V
- Lenovo XClarity VM: Provides hardware management services.

The System x3650 M5 hyperconverged nodes provide compute and storage resources and includes the following software components:

- Windows Server 2016 with Hyper-V.
- Azure Stack software: Provides scalable hybrid cloud platform.
- Storage Spaces Direct (S2D): Provides highly available, scale-out storage for the cloud workloads.

Network connectivity is provided by the Lenovo RackSwitch switches. The management network consists of one RackSwitch G8052 1 GbE switch that runs Enterprise Network Operating System (ENOS), and the VM/storage network consists of two RackSwitch G8272 10 GbE switches that run Cloud Network Operating System (CNOS).

The front and rear views of the ThinkAgile SXM4200 25U are shown in the following figure.

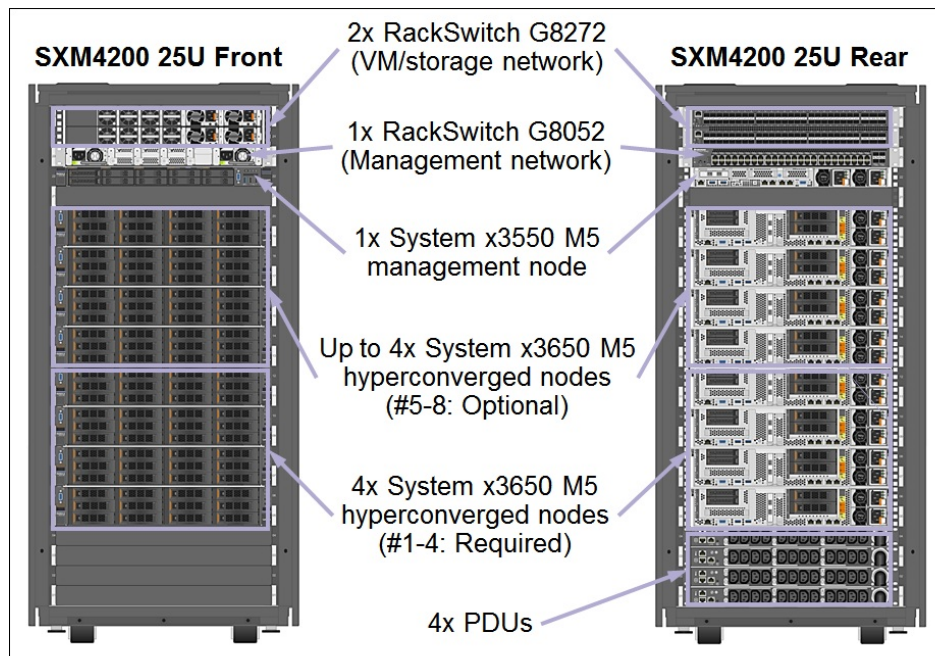

Figure 2. ThinkAgile SXM4200 25U front and rear views

The front and rear views of the ThinkAgile SXM4200 42U are shown in the following figure.

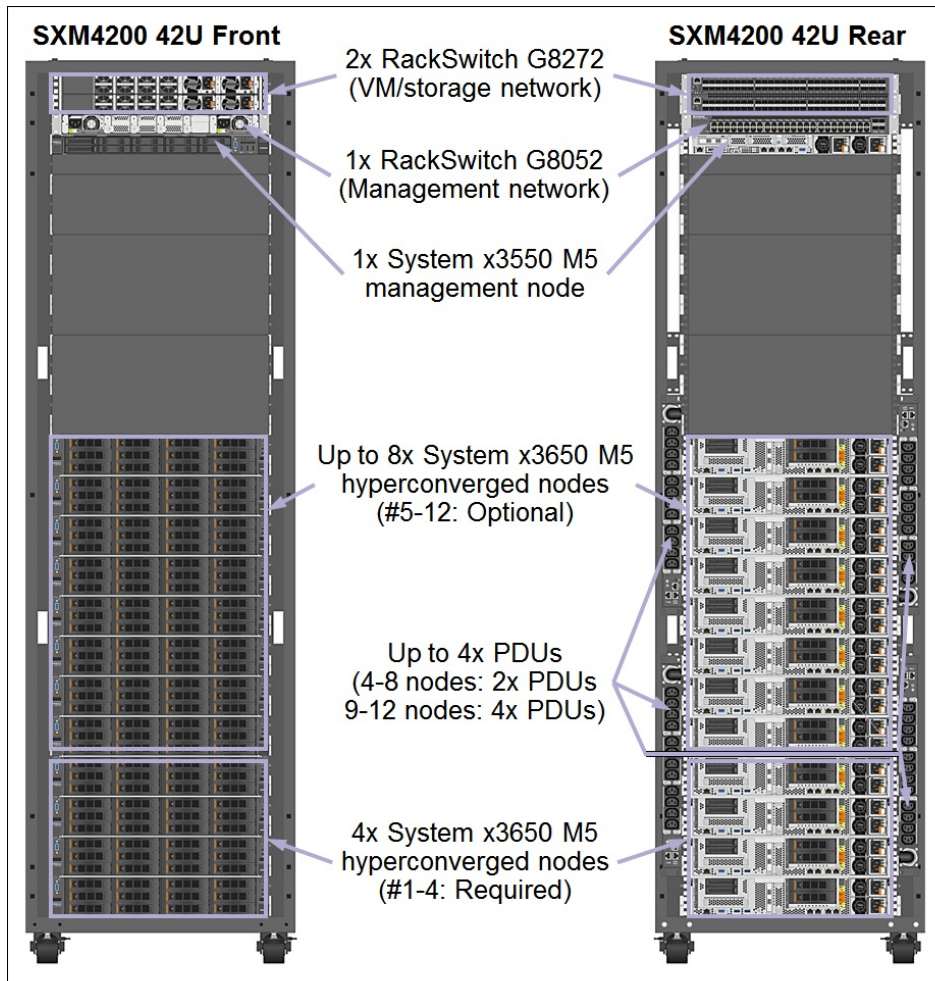

Figure 3. ThinkAgile SXM4200 42U front and rear views

The front and rear views of the ThinkAgile SXM6200 are shown in the following figure.

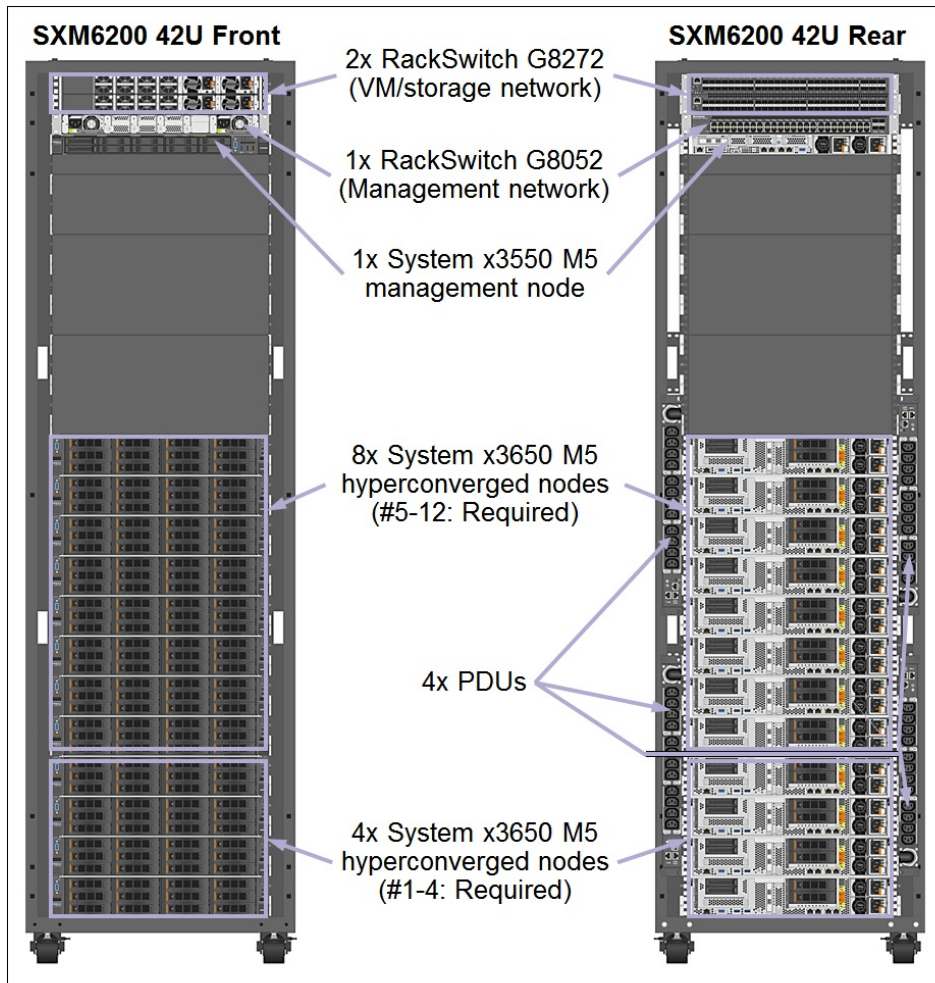

Figure 4. ThinkAgile SXM6200 front and rear views

## System specifications

The following table lists the system specifications of the ThinkAgile SX for Microsoft Azure Stack.

Table 1. ThinkAgile SX for Microsoft Azure Stack system specifications

Attribute	ThinkAgile SX for Microsoft Azure Stack model specifications		
	SXM4200 25U	SXM4200 42U	SXM6200
Form factor	25U Rack cabinet (9565-RCC)	42U Rack cabinet (9565-RCD)	42U Rack cabinet (9565-RCE)
Dimensions	<ul style="list-style-type: none"> <li>Height: 1244 mm</li> <li>Width: 605 mm</li> <li>Depth: 1000 mm</li> </ul>	<ul style="list-style-type: none"> <li>Height: 2009 mm</li> <li>Width: 600 mm</li> <li>Depth: 1096 mm</li> </ul>	<ul style="list-style-type: none"> <li>Height: 2009 mm</li> <li>Width: 600 mm</li> <li>Depth: 1096 mm</li> </ul>
Total rack load capacity	570 kg	953 kg	953 kg
Maximum rack weight	670 kg	1127 kg	1127 kg
AC power distribution	<ul style="list-style-type: none"> <li>4x C13 PDUs (1-Ph, 30A/208V, NEMA L6-30P)</li> <li>4x C13 PDUs (1-Ph, 32A/230V, IEC 309 P+N+G)</li> </ul>	<ul style="list-style-type: none"> <li>2x (4-8 nodes) or 4x (9-12 nodes) C13 PDUs (1-Ph, 60A/208V, IEC 309 2P+G)</li> <li>2x (4-8 nodes) or 4x (9-12 nodes) C13 PDUs (1-Ph, 63A/230V, IEC 309 P+N+G)</li> <li>2x (4-8 nodes) or 4x (9-12 nodes) C13 PDUs (3-Ph, 32A/380-415V, IEC 309 3P+N+G)</li> </ul>	
	All PDUs in a rack cabinet should be of the same type. IEC 320-C13 to C14 AC power cables for connecting all the equipment in a rack cabinet to PDUs are included.		
Hardware warranty	Three-, four-, or five-year customer-replaceable unit and onsite limited warranty with ThinkAgile Advantage Support and selectable service levels: 9x5 next business day (NBD) parts delivered, 24x7x4, or 24x7x2 response (parts delivered or onsite) or 6-hour or 24-hour committed repair (select countries). Also available are 1-year and 2-year post-warranty extensions, Your Drive Your Data and Premier Support.		
Software	Microsoft Windows Server 2016 with Hyper-V, Microsoft Storage Spaces Direct, Microsoft Azure Stack, Lenovo XClarity Administrator with XClarity Pro 3-year software support license.		
<b>Management node</b>			
Base model	Lenovo System x3550 M5 for ThinkAgile SXM (8869-ACD)		
Quantity	1		
Processor	Two Intel Xeon E5-2620 v4 processors.		
Memory	64 GB (8x 8 GB TruDDR4 RDIMMs). ECC memory protection.		
Drive bays	10x 2.5-inch SAS/SATA hot-swap		
Internal storage	2x 2.5" 800 GB Enterprise Performance 12 Gbps SAS SSDs (RAID-1 boot volume)		
Storage controller	1x M5210 (12 Gbps SAS)		
Network interfaces	<ul style="list-style-type: none"> <li>One dual-port 25 GbE SFP28 adapter (Mellanox ConnectX-4 Lx) (one port is connected to the management network switch with one 1m SFP+ DAC cable included [the port operates at 10 Gbps]).</li> <li>4x 1 GbE ports (RJ-45) (Not used).</li> <li>1x 1 GbE dedicated IMM management port (RJ-45) connected to the management network switch with one UTP Category 5E cable included.</li> </ul>		
Ports	<ul style="list-style-type: none"> <li>Front: 3x USB 2.0 ports and 1x VGA port.</li> <li>Rear: 2x USB 3.0 ports and 1x VGA port.</li> </ul>		

Attribute	ThinkAgile SX for Microsoft Azure Stack model specifications		
	SXM4200 25U	SXM4200 42U	SXM6200
I/O expansion slots	Four slots: <ul style="list-style-type: none"> <li>Slot 1: PCIe 3.0 x16; low profile (for the network adapter)</li> <li>Slot 2: PCIe 3.0 x16; low profile (not used)</li> <li>Slot 3: PCIe 3.0 x16; low profile (not used)</li> <li>Slot 4: PCIe 3.0 x8 (for the M5210 RAID controller)</li> </ul>		
Management features	Integrated Management Module II (IMM2.1) with Advanced Upgrade for remote presence (graphics, keyboard and mouse, virtual media), predictive alerts, light path diagnostics.		
Security features	Power-on password, administrator's password, Trusted Platform Module (TPM) 2.0 and Secure Boot.		
Video	Matrox G200eR2 with 16 MB memory integrated into the IMM2.1. Maximum resolution is 1600x1200 at 75 Hz with 16 M colors.		
Cooling	Seven redundant hot-swap system fans; dual fan zones with N+1 fan redundancy.		
Power supplies	Two redundant hot-swap 750 W High Efficiency Titanium AC power supplies.		
Hyperconverged nodes			
Base model	Lenovo System x3650 M5 for ThinkAgile SXM (8871-ACB)		
Expansion model	Lenovo System x3650 M5 Expansion for ThinkAgile SXM (8871-ACC)		
Quantity	4 - 8	4 - 12	12
Processor	Two Intel Xeon E5-2600 v4 processors.		
Memory	24 DIMM sockets with support for 8x or 16x 16 GB RDIMMs or 8x, 16x, or 24x 32 GB RDMMs. Memory speed up to 2400 MHz. ECC and Chipkill memory protection.		
Memory capacity	Up to 768 GB with 24x 32 GB RDIMMs.		
Drive bays	14x 3.5-inch SAS/SATA hot-swap (front) + 2x 2.5-inch SAS/SATA hot-swap (rear)		
Internal storage	<ul style="list-style-type: none"> <li>Boot volume:               <ul style="list-style-type: none"> <li>2x 600GB 10K 12Gbps SAS 2.5" G3HS HDDs in a RAID-1 drive group</li> </ul> </li> <li>Storage Spaces Direct:               <ul style="list-style-type: none"> <li>4x 800GB Enterprise Performance 12G SAS HS 3.5" SSDs + 10x 4TB 7.2K 6Gbps NL SATA 3.5" G2HS HDDs; or</li> <li>4x 1.6TB Enterprise Performance 12G SAS HS 3.5" SSDs + 10x 6TB 7.2K 6Gbps NL SATA 3.5" G2HS 512e HDD.</li> </ul> </li> </ul>		
Storage controller	<ul style="list-style-type: none"> <li>1x ServerRAID M1215 (12 Gbps SAS) for boot volume.</li> <li>1x ServerRAID N2215 (12 Gbps SAS/6 Gbps SATA) for Storage Spaces Direct.</li> </ul>		
Network interfaces	<ul style="list-style-type: none"> <li>One dual-port 25 GbE SFP28 adapter (Mellanox ConnectX-4 Lx) connected to the VM/storage network switches with two SFP+ DAC cable included (the ports operate at 10 Gbps).</li> <li>4x 1 GbE ports (RJ-45) (Not used).</li> <li>1x 1 GbE dedicated IMM management port (RJ-45) connected to the management network switch with one UTP Category 5E cable included.</li> </ul>		
Ports	<ul style="list-style-type: none"> <li>Front: 2x USB 2.0 ports.</li> <li>Rear: 2x USB 3.0 ports and 1x VGA port.</li> </ul>		
I/O expansion slots	Four slots: <ul style="list-style-type: none"> <li>Slot 3: PCIe 3.0 x8; full-height, half-length (for the M1215 RAID controller)</li> <li>Slot 4: PCIe 3.0 x8; low profile (for the network adapter)</li> <li>Slot 5: PCIe 3.0 x8; low profile (not used)</li> <li>Slot 9: PCIe 3.0 x8 (for the N2215 HBA)</li> </ul>		

Attribute	ThinkAgile SX for Microsoft Azure Stack model specifications		
	SXM4200 25U	SXM4200 42U	SXM6200
Management features	Integrated Management Module II (IMM2.1) with Advanced Upgrade for remote presence (graphics, keyboard and mouse, virtual media), predictive alerts, light path diagnostics.		
Security features	Power-on password, administrator's password, Trusted Platform Module (TPM) 2.0 and Secure Boot.		
Video	Matrox G200eR2 with 16 MB memory integrated into the IMM2.1. Maximum resolution is 1600x1200 at 75 Hz with 16 M colors.		
Cooling	Six redundant hot-swap system fans; dual fan zones with N+1 fan redundancy.		
Power supplies	Two redundant hot-swap 900 W High Efficiency Platinum AC power supplies.		
<b>Networking</b>			
Management network	1x RackSwitch G8052 Gigabit Ethernet switch (7159-HCH) with 48x 1 GbE RJ-45 ports and 4x SFP/SFP+ uplink ports.		
VM/storage network	2x RackSwitch G8272 10 Gb Ethernet switches (7159-HCF), each with 48x 10 GbE SFP/SFP+ and 6x 40 GbE QSFP+ ports.		
VM network uplinks	4x 10 GbE upstream VLAG connections (2x per G8272) with SFP+ SR transceivers using customer-supplied MMF OM3 or OM4 fiber optic cables with LC connectors.		
Management interfaces	<ul style="list-style-type: none"> <li>• G8052: In-band management</li> <li>• G8272: 1x 10/100/1000 Mb Ethernet</li> </ul>		
Software features	<ul style="list-style-type: none"> <li>• G8052 (Enterprise Networking Operating System [ENOS]): Layer 2 and Layer 3 switching, VLANs, VLAN tagging, spanning tree, link aggregation, Hot Links, Layer 2 failover, VRRP, QoS, IP v4/v6 management and routing.</li> <li>• G8272 (Cloud Networking Operating System [CNOS]): Layer 2 and Layer 3 switching, VLANs, VLAN tagging, spanning tree, link aggregation, virtual link aggregation, VRRP, QoS, CEE, IP v4/v6 management and routing.</li> </ul>		
Cooling	<ul style="list-style-type: none"> <li>• G8052: Three 2+1 redundant hot-swap fans.</li> <li>• G8272: Four 3+1 redundant hot-swap fans.</li> </ul>		
Power supplies	<ul style="list-style-type: none"> <li>• G8052: Two redundant hot-swap 450 W AC</li> <li>• G8272: Two redundant hot-swap 460 W AC</li> </ul>		

## Models

Factory-integrated SXM4200 and SXM6200 models of the ThinkAgile SX for Microsoft Azure Stack are configured by using the Lenovo Data Center Solution Configurator (DCSC): <http://dcsc.lenovo.com>

**Note:** You are required to engage a Lenovo representative in the project that includes the ThinkAgile SX for Microsoft Azure Stack.

The configuration process includes the following steps:

- Model selection
  - SXM4200
  - SXM6200
- Rack cabinet selection
  - 25U (SXM4200 only)
  - 42U (SXM4200 and SXM6200)
- Power distribution infrastructure selection
  - 208 V AC single-phase (US)
  - 230 V AC single-phase (non-US)



- Node configuration
  - One management node is derived
  - Hyperconverged nodes:
    - Processor model
    - Memory capacity
    - Storage capacity
    - Node quantity
- Networking selection
  - Switch models are derived
- Software selection
  - Microsoft Azure Stack software is derived
  - Lenovo XClarity Administrator with Pro license is derived
- Warranty:
  - Three, four, or five years of warranty service coverage
  - 9x5 Next Business Day response with parts delivered (default selection) or onsite response
  - 24x7 4-hour or 2-hour onsite response or 24x7 6-hour committed service repair (available only in select regions)
  - Premier services (optional)
  - YourDrive YourData (optional)
- Services:
  - Lenovo ThinkAgile Advantage services (included): Deployment services and single point of support
  - Health check (onsite firmware updates from Lenovo) (optional)
  - Managed services (remote monitoring and management by Lenovo managed services team) (optional)

The existing ThinkAgile SX for Microsoft Azure Stack deployments can be expanded up to the maximum number of hyperconverged nodes supported by ordering the expansion node models. Field expansion is handled by Lenovo professional services via a service contract.

**Note:** The configuration of the expansion nodes must be the same as for the existing base nodes.

## Rack cabinets

The following table lists the base models of the ThinkAgile SX for Microsoft Azure Stack rack cabinets.

Table 2. Base models of the ThinkAgile SX for Microsoft Azure Stack rack cabinets

Description	Machine Type-Model	Feature code	SXM4200 25U	SXM4200 42U	SXM6200
ThinkAgile SXM4200 25U Rack	9565-RCC	AX7U	Y	N	N
ThinkAgile SXM4200 42U Rack	9565-RCD	AX7V	N	Y	N
ThinkAgile SXM6200 42U Rack	9565-RCE	AX7W	N	N	Y

**Configuration note:** 1U, 3U, and 5U Filler panels are derived based on the number of nodes selected.

## Power distribution

Power distribution units (PDUs) are used to distribute power from an uninterruptible power supply (UPS) or utility power to the equipment within the ThinkAgile SX for Microsoft Azure Stack rack cabinet and to provide fault-tolerant power redundancy for high availability.

Each node, management network switch, and VM/storage network switch has two redundant power supplies, and each of two power supplies is connected to a separate PDU to support topologies with redundant AC power sources.

The power distribution topology is illustrated in the following figure.

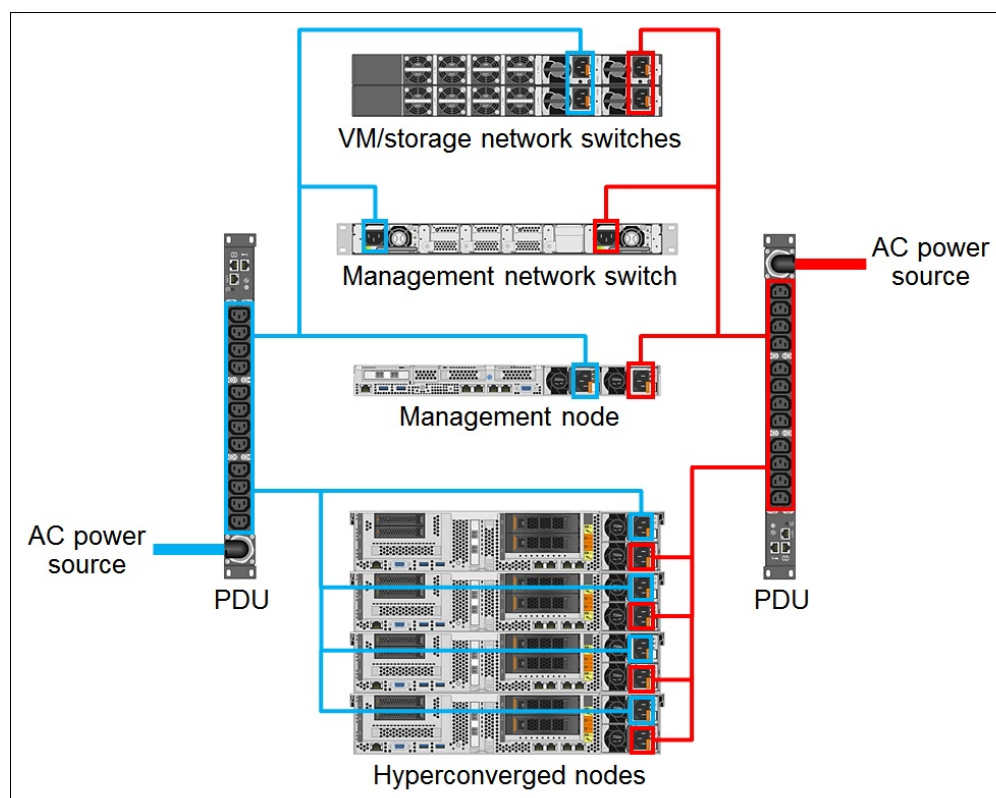

Figure 5. Power distribution topology

The following table lists the PDUs for the ThinkAgile SX for Microsoft Azure Stack rack cabinets.

Table 3. Power distribution units

Description	Feature code	Quantity	SXM4200 25U	SXM4200 42U	SXM6200
1U 12 C13 Switched and Monitored 30A/208V, NEMA L6-30P 1-Phase PDU	5908	4	Y	N	N
1U 12 C13 Switched and Monitored 32A/230V, IEC 309 P+N+G 1-Phase PDU	5910	4	Y	N	N
1U 12 C13 Switched and Monitored 60A/208V, IEC 309 2P+G 1-Phase PDU	5909	2 / 4*	N	Y	Y
1U 12 C13 Switched and Monitored 63A/230V, IEC 309 P+N+G 1-Phase PDU	5911	2 / 4*	N	Y	Y
1U 12 C13 Switched and Monitored 32A/380-415V, IEC 309 3P+N+G 3-Ph. PDU	5912	2 / 4*	N	Y	Y

\* The PDU quantity shown is for 4 - 8 hyperconverged nodes / 9 - 12 hyperconverged nodes.

### Configuration notes:

- Only one type of PDUs is supported within the ThinkAgile SX for Microsoft Azure Stack rack cabinet; different PDU types cannot be mixed within the rack cabinet.
- Power cables are derived based on the ThinkAgile SX for Microsoft Azure Stack model and the number of nodes selected.

The following table summarizes the PDU specifications.

Table 4. PDU specifications

Feature	1U 12 C13 Switched and Monitored DPI PDU				
Feature code	5908	5910	5909	5911	5912
Phase	Single-phase	Single-phase	Single-phase	Single-phase	3-phase WYE
Voltage	208 V AC	230 V AC	208 V AC	230 V AC	380-415 V AC (220-240 V AC)
Line cord input amperage	24 A	32 A	48 A	63 A	32 A / phase
Line cord input connector	NEMA L6-30P	IEC 309 P+N+G	IEC 309 2P+G	IEC 309 P+N+G	IEC 309 3P+N+G
Output connectors	12x IEC 320-C13	12x IEC 320-C13	12x IEC 320-C13	12x IEC 320-C13	12x IEC 320-C13

### Management node

The ThinkAgile SX for Microsoft Azure Stack uses the Lenovo System x3550 M5 server as a management node.

The System x3550 M5 is a cost- and density-balanced 1U, dual-socket server featuring Intel Xeon processor E5-2600 v4 product family and faster, energy-efficient TruDDR4 memory. It offers improved performance and pay-as-you grow flexibility with leadership security, efficiency, and reliability features.

The following table lists the base configuration of the System x3550 M5 for ThinkAgile SXM that is derived.

Table 5. System x3550 M5 for ThinkAgile SX base configuration

Machine Type-Model	Intel Xeon processor	Memory	Storage controller	Drives	Network	Power supply
8869-ACD	2x E5-2620 v4	64 GB (8x 8 GB)	1x M5210	2x 2.5" 800 GB SSDs	1x 10 GbE	2x 750W HS

### Processors

The System x3550 M5 for ThinkAgile SXM requires two Intel Xeon E5-2620 v4 processors. The following table lists the specifications of the processors for the System x3550 M5 for ThinkAgile SXM.

Table 6. CPU specifications (HT = Hyper-Threading, TB = Turbo Boost, VT = Virtualization Technology)

Processor model	Core frequency (Base / TB Max)	Number of cores / threads	Cache	Max DDR4 frequency	QPI speed	TDP	HT	TB	VT-x	VT-d
E5-2620 v4	2.1 / 3 GHz	8 / 16	20 MB	2133 MHz	8.0 GT/s	85 W	Yes	Yes	Yes	Yes

The following table lists feature codes of the derived processors.

Table 7. Processor feature codes

Description	Feature codes*
Intel Xeon Processor E5-2620 v4 8C 2.1GHz 20MB Cache 2133MHz 85W	ATLV / ATMK

\* The first feature code is for the first processor; the second feature code is for the second processor.

## Memory

The System x3550 M5 for ThinkAgile SXM supports 64 GB of memory with 8x 8 GB (2Rx8) 2400 MHz TruDDR4 RDIMMs. Each processor has four memory channels, and there is one DIMM per channel installed. The operating memory speed is 2133 MHz. The memory DIMMs support ECC protection.

The following table lists memory RDIMMs derived for the System x3550 M5 for ThinkAgile SXM.

Table 8. Memory RDIMMs

Description	Feature code	Quantity
8GB TruDDR4 Memory (2Rx8, 1.2V) PC4-19200 CL17 2400MHz LP RDIMM	ATC9	8

## Internal storage

The System x3550 M5 management node has 10x 2.5" hot-swap drive bays connected to the ServeRAID M5210 SAS/SATA Controller.

The following table lists the internal drive configuration for the management node.

Table 9. Internal drive configuration: Management node

Model	4x 2.5-inch hot-swap front drive bays		
	Quantity, drive types	Drive layout	Storage controller
x3550 M5 for ThinkAgile SXM	2x 800GB 12Gb SAS SSDs	RAID-1 (2x SSDs) boot volume	1x M5210

The following table lists the SSDs derived for the x3550 M5 management node.

Table 10. SSDs for management node

Description	Feature code	Quantity
800GB Enterprise Performance 12G SAS G3HS 2.5" SSD	AVL1	2

## Network connectivity

For the management network, the System x3550 M5 for ThinkAgile SXM uses 10 GbE connectivity with the dual-port 25 GbE Mellanox ConnectX-4 Lx network adapter: One port that operates at 10 Gbps is connected to the management switch. Also, the 1 GbE dedicated management port on the IMM is connected to the management network switch. For more information, refer to [Networking](#).

The following table lists the network adapter derived for the management node.

Table 11. Network adapter

Description	Feature code	Quantity
Mellanox ConnectX-4 Lx 2x25GbE SFP28 Adapter	AUAJ	1

**Configuration note:** The 1.5m UTP Cat5e cable for the management network connection and the 1m 10 GbE SFP+ DAC cable for the management network connection are included.

For more information about the System x3550 M5 server, refer to the Lenovo Press Product Guide: <http://lenovopress.com/lp0067>

## Hyperconverged nodes

The ThinkAgile SX for Microsoft Azure Stack uses the Lenovo System x3650 M5 servers as hyperconverged nodes.

The System x3650 M5 is a versatile 2U dual-socket business-critical server that offers improved performance and comprehensive systems management tools that help make deployment easier. Outstanding reliability, availability, and serviceability (RAS) and high-efficiency design improve your business environment and help save operational costs.

The following table lists the base configuration of the System x3650 M5 for ThinkAgile SXM.

Table 12. System x3650 M5 for ThinkAgile SXM base configuration

Machine Type-Model	Intel Xeon processor	Memory (min / max)	Storage controller	Drives	Network	Power supply
Initial deployment						
8871-ACB	2x E5-2600 v4*	128 GB / 768 GB**	1x N2215 1x M1215	2x 2.5" 600 GB HDDs 4x 3.5" SSDs*** 10x 3.5" HDDs***	2x 10 GbE	2x 900W HS
Field expansion						
8871-ACB	2x E5-2600 v4*	128 GB / 768 GB**	1x N2215 1x M1215	2x 2.5" 600 GB HDDs 4x 3.5" SSDs*** 10x 3.5" HDDs***	2x 10 GbE	2x 900W HS

\* Processor model is selectable (See Processors for details).

\*\* Memory capacity is configurable (See Memory for details).

\*\*\* Drives are configurable: 4x 800 GB SSDs + 10x 4 TB HDDs or 4x 1.6 TB SSDs + 10x 6 TB HDDs (See Storage for details).

## Processors

The System x3650 M5 for ThinkAgile SXM requires two Intel Xeon E5-2640 v4 processors. The following table lists the specifications of the processors for the System x3650 M5 for ThinkAgile SXM.

Table 13. CPU specifications (HT = Hyper-Threading, TB = Turbo Boost, VT = Virtualization Technology)

Processor model	Core frequency (Base / TB Max)	Number of cores / threads	Cache	Max DDR4 frequency	QPI speed	TDP	HT	TB	VT-x	VT-d
E5-2680 v4	2.4 / 3.3 GHz	14 / 28	35 MB	2400 MHz	9.6 GT/s	120 W	Yes	Yes	Yes	Yes
E5-2683 v4	2.1 / 3 GHz	16 / 32	40 MB	2400 MHz	9.6 GT/s	120 W	Yes	Yes	Yes	Yes
E5-2690 v4	2.6 / 3.5 GHz	14 / 28	35 MB	2400 MHz	9.6 GT/s	135 W	Yes	Yes	Yes	Yes
E5-2695 v4	2.1 / 3.3 GHz	18 / 36	45 MB	2400 MHz	9.6 GT/s	120 W	Yes	Yes	Yes	Yes
E5-2698 v4	2.2 / 3.6 GHz	20 / 40	50 MB	2400 MHz	9.6 GT/s	135 W	Yes	Yes	Yes	Yes
E5-2699 v4	2.2 / 3.6 GHz	22 / 44	55 MB	2400 MHz	9.6 GT/s	145 W	Yes	Yes	Yes	Yes

The following table lists feature codes of the supported processors.

Table 14. Processor feature codes

Description	Feature codes*
Intel Xeon Processor E5-2680 v4 14C 2.4GHz 35MB Cache 2400MHz 120W	ATET / ATFJ
Intel Xeon Processor E5-2683 v4 16C 2.1GHz 40MB Cache 2400MHz 120W	ATF7 / ATFY
Intel Xeon Processor E5-2690 v4 14C 2.6GHz 35MB Cache 2400MHz 135W	ATER / ATFG
Intel Xeon Processor E5-2695 v4 18C 2.1GHz 45MB Cache 2400MHz 120W	ATEX / ATFN
Intel Xeon Processor E5-2698 v4 20C 2.2GHz 50MB Cache 2400MHz 135W	ATF3 / ATFU
Intel Xeon Processor E5-2699 v4 22C 2.2GHz 55MB Cache 2400MHz 145W	ATF2 / ATFT

\* The first feature code is for the first processor; the second feature code is for the second processor.

## Memory

The System x3650 M5 for ThinkAgile SXM supports up to 768 GB of memory with 24x 32 GB (2Rx4) 2400 MHz TruDDR4 RDIMMs. Each processor has four memory channels, and there are three DIMMs per channel. All DIMMs in the system operate at the same memory speed up to 2400 MHz, which is determined by the selected quantity of DIMMs per channel.

**Note:** Maximum memory speed can be achieved when Max performance mode is enabled in UEFI.

The following memory protection technologies are supported:

- ECC
- Chipkill

System x engineering tested and validated system designs that support memory speeds beyond Intel memory specifications, which provides benefits for workloads that require memory speed and density. System x TruDDR4 memory is fully supported up to the rated speeds that are shown in the following table. Table cells highlighted with a gray background indicate when the DIMMs are allowed to operate at a higher speed than Intel specifications define.

Table 15. System x3650 M5 maximum memory speeds and capacities

DIMMs per channel	RDIMM	
	Memory bus speed	Maximum capacity
1 DPC	2400 MHz	256 GB (8x 32 GB)
2 DPC	2400 MHz	512 GB (16x 32 GB)
3 DPC	1866 MHz	768 GB (24x 32 GB)

The following table lists memory selection options available for the System x3650 M5 for ThinkAgile SXM.

Table 16. Memory options

Description	Feature code	Quantity supported
16GB TruDDR4 Memory (2Rx4, 1.2V) PC4-19200 CL17 2400MHz LP RDIMM	ATCA	8, 16
32GB TruDDR4 Memory (2Rx4, 1.2V) PC4-19200 CL17 2400MHz LP RDIMM	ATCB	8, 16, 24

## Internal storage

Each System x3650 M5 hyperconverged node has 14x 3.5" hot-swap drive bays (12 on the front; 2 on the rear) and 2x 2.5" hot-swap rear drive bays.

The 3.5-inch drive bays are used for data storage, and they are connected to the N2215 SAS/SATA HBA (JBOD mode).

For the boot volume, the hyperconverged nodes use the 2.5" rear drive bays with 2x 2.5" 600GB 10K rpm 12 Gb SAS HS HDDs connected to the ServeRAID M1215 SAS/SATA Controller. The drives are configured in a RAID-1 group that provides highly available boot volume for the system software.

The following table lists the internal drive configuration for the data storage of the hyperconverged nodes.

Table 17. Internal drive configuration: Data storage

Model	12x 3.5-inch (front) + 2x 3.5-inch (rear) hot-swap drive bays (data storage)		
	Quantity, drive types	Drive layout	Storage controller
x3650 M5 for ThinkAgile SXM	Config 1: <ul style="list-style-type: none"> <li>4x 800GB 12Gb SAS SSDs</li> <li>10x 4TB 7.2K 6Gb NL SATA HDDs</li> </ul> Config 2: <ul style="list-style-type: none"> <li>4x 1.6TB 12Gb SAS SSDs</li> <li>10x 6TB 7.2K 6Gb NL SATA HDDs</li> </ul>	4x SSDs (JBOD) S2D caching 10x HDDs (JBOD) S2D capacity	1x N2215

The following table lists the internal drive configurations for the boot volume of the hyperconverged nodes.

Table 18. Internal drive configurations: Boot volume

Model	2.5-inch hot-swap rear drive bays (boot volume)		
	Quantity, drive types	Drive layout	Storage controller
x3650 M5 for ThinkAgile SXM	2x 600GB 10K 12Gbps SAS 2.5" G3HS HDD	1x RAID 1 (2x HDDs) boot volume	1x M1215

The following table lists the HDD and SSD selection options for the x3650 M5 hyperconverged nodes.

Table 19. HDDs and SSDs for hyperconverged nodes: Data storage

Description	Feature code	Quantity	
		Config 1	Config 2
3.5-inch hot-swap HDDs - 6 Gbps NL SATA			
4TB 7.2K 6Gbps NL SATA 3.5" G2HS HDD	A3W9	10	-
6TB 7.2K 6Gbps NL SATA 3.5" G2HS 512e HDD	A5VM	-	10
3.5-inch hot-swap SSDs - 12 Gbps SAS			
800GB Enterprise Performance 12G SAS HS 3.5" SSD	AVL4	4	-
1.6TB Enterprise Performance 12G SAS HS 3.5" SSD	AVL5	-	4



The following table lists the HDD derived for the boot volume of the x3650 M5 hyperconverged nodes.

Table 20. Boot volume HDD

Description	Feature code	Quantity
600GB 10K 12Gbps SAS 2.5" G3HS HDD	AT8A	2

### Network connectivity

For the management network, the System x3650 M5 for ThinkAgile SXM uses 1 GbE connectivity with the 1 GbE dedicated management port on the IMM that is connected to the management network switch.

For the VM/storage network, the System x3650 M5 for ThinkAgile SXM provides two-port 10 GbE connectivity with the dual-port 25 GbE Mellanox ConnectX-4 Lx network adapter: Each port that operates at 10 Gbps is connected to a separate VM/storage switch. For more information, refer to [Networking](#).

The following table lists the network adapter derived for the hyperconverged nodes.

Table 21. Network adapter

Description	Feature code	Quantity
Mellanox ConnectX-4 Lx 2x25GbE SFP28 Adapter	AUAJ	1

**Configuration note:** All required UTP cables for the management network connections and 10 GbE SFP+ DAC cables for the VM/storage network connections are included.

For more information about the System x3650 M5 server, refer to the Lenovo Press Product Guide: <http://lenovopress.com/lp0068>

### Networking

The ThinkAgile SX for Microsoft Azure Stack uses one Lenovo RackSwitch G8052 1 GbE switch for management network connectivity and two Lenovo RackSwitch G8272 10 GbE switches for VM/storage network connectivity.

Dedicated IMM management ports (on the management node and hyperconverged nodes) and management ports on the G8272 VM/storage network switches are connected to the G8052 management network switch via 1 GbE links. The 10 GbE port on the management node is connected to an SFP+ port on the management switch. The management network switch is connected to two VM/storage network switches via 10 GbE links.

10 GbE hyperconverged node ports on the dual-port adapters are connected to a pair of the G8272 VM/storage network switches. The switches are connected to each other via two 40 GbE links (provided by two 40 Gb QSFP+ active optical cables (AOCs) included) that are configured in a link aggregation group (LAG). Each of two G8272 switches provides two 10 GbE uplinks (10 GbE SR SFP+ transceivers) that are configured in a virtual link aggregation group (vLAG) for upstream network integration. VM/storage network uplinks require customer-supplied MMF OM3 or OM4 fiber optic cables with LC connectors.

The network connectivity topology is illustrated in the following figure.

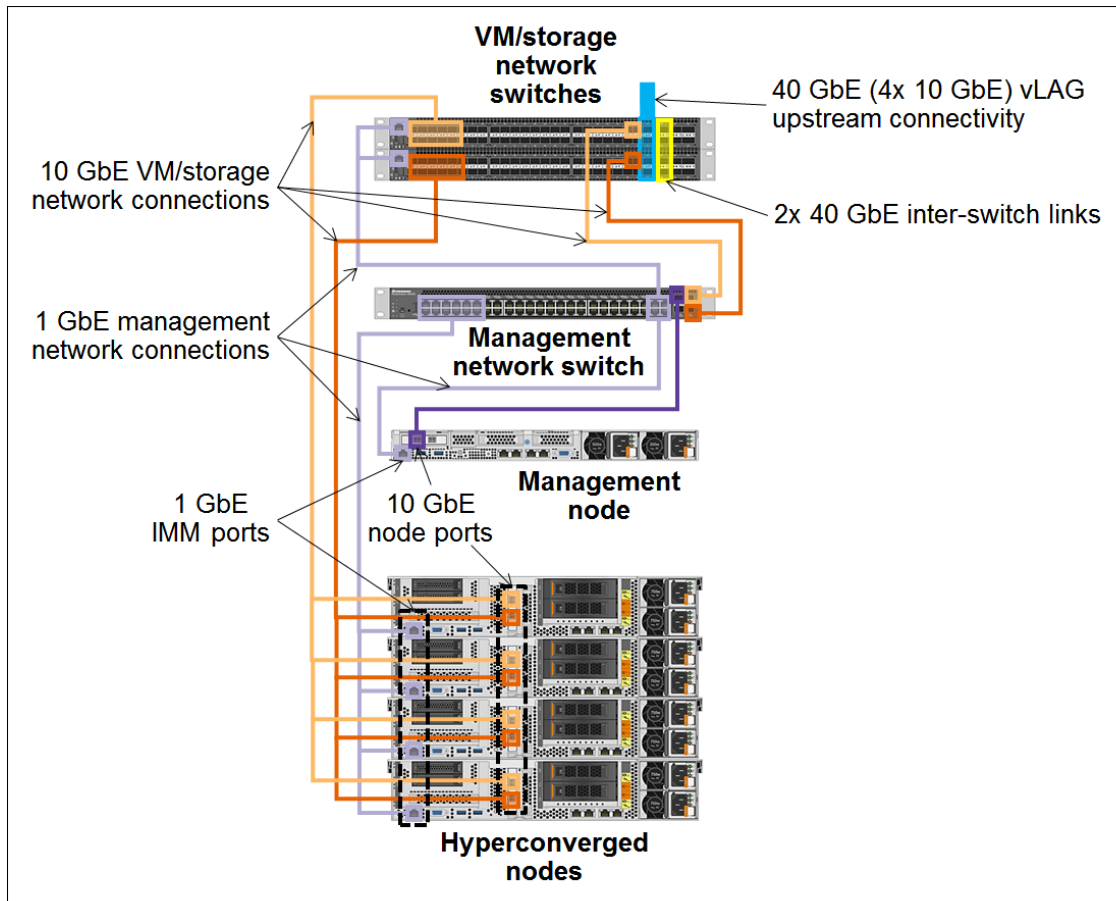

Figure 6. Network connectivity topology

The following table lists the derived network switches.

Table 22. RackSwitch for ThinkAgile SXM Series

Description	Machine Type-Model	Feature code	Quantity
1 GbE management network			
RackSwitch G8052 (Rear to Front) for ThinkAgile SXM	7159-HCH	AX80	1
10 GbE VM/storage network			
RackSwitch G8272 (Rear to Front) for ThinkAgile SXM	7159-HCF	AX81	2

The following table summarizes specifications of the RackSwitch switches for ThinkAgile SXM.

Table 23. RackSwitch specifications summary

Feature	G8052	G8272
Ports	<ul style="list-style-type: none"> <li>• 48x GbE RJ-45 fixed</li> <li>• 4x SFP/SFP+</li> </ul>	<ul style="list-style-type: none"> <li>• 48x SFP/SFP+</li> <li>• 6x QSFP+</li> </ul>
Media types	<ul style="list-style-type: none"> <li>• RJ-45: UTP Category 5, 5e, 6</li> <li>• SFP+: 10 GbE DAC cables</li> </ul>	<ul style="list-style-type: none"> <li>• SFP+: 10 GbE SR SFP+ 10 GbE DAC cables</li> <li>• QSFP+: 40 GbE AOCs</li> </ul>
Management ports	In-band management	1x GbE RJ-45
Layer 2 switching	Yes	Yes
Layer 3 switching	Yes	Yes
VLANs	Yes	Yes
VLAN tagging	Yes	Yes
Link aggregation	Yes	Yes
Virtual link aggregation	Yes	Yes
Quality of Service	Yes	Yes
IPv4/IPv6 management	Yes	Yes
IPv4/IPv6 routing	Yes	Yes
Converged Enhanced Ethernet	No	Yes
Cooling	3x hot-swap fans (2+1 redundancy)	4x hot-swap fans (3+1 redundancy)
Power supplies	2x 450 W AC redundant hot-swap	2x 460 W AC redundant hot-swap

The following table lists the SFP+ transceiver that is derived for the G8272 uplink ports.

Table 24. SFP+ transceiver for the G8272

Description	Feature code	Quantity (min / max)
10 GbE SFP+ SR Transceiver	5053	2 / 2

**Configuration note:** All UTP Category 5E cables for the 1 GbE management network and 10 GbE SFP+ DAC cables for the VM/storage network are derived based on the number of nodes selected.

For more information about the RackSwitch switches, see the following Lenovo Press Product Guides:

- Lenovo RackSwitch G8052  
<http://lenovopress.com/tips1270>
- Lenovo RackSwitch G8272  
<http://lenovopress.com/tips1267>

## Software

The ThinkAgile SX for Microsoft Azure Stack includes the following software components:

- Microsoft Azure Stack
- Lenovo XClarity Pro

### Microsoft Azure Stack

The Microsoft Azure Stack running on ThinkAgile SXM offers the following key features:

- Administrator portal
  - Provides a web-based interface for the cloud infrastructure to perform administrative tasks
  - Supports management of cloud resources and services
  - Enables creation of plans, offers, and subscriptions for tenant users
  - Allows monitoring of health and alerts and managing capacity
- User (Tenant) portal
  - Provides a web-based self-service interface for tenants to interact with the cloud
  - Supports provisioning, monitoring, and management of services for subscribed tenants
- Identity management
  - Provides authentication and authorization for cloud services
  - Uses Azure Active Directory (AAD) or Active Directory Federation Services (AD FS)
  - Supports role-based access control (RBAC) to manage access to resources and services
- Compute Resource Provider
  - Manages lifecycle of Virtual Machines (VMs) in a cloud environment
  - Creates, updates, and deletes VM images
  - Manages VM snapshots, restore points, and availability sets
- Network Resource Provider
  - Delivers Software Defined Networking (SDN) and Network Function Virtualization (NFV)
  - Implements network isolation and segmentation with virtual networks
  - Enables communications across virtual networks with traffic routing
  - Secures cloud resources by filtering network traffic with network security groups
  - Offers load balancing across multiple instances for enhanced availability and performance
- Storage Resource Provider
  - Delivers cloud storage services
  - Supports unstructured objects, structured datasets, message queuing, and SMB file storage
  - Offers storage cloud administration service
- Azure Resource Manager
  - Interacts with resource providers and enables cloud orchestration
  - Automates the deployment of infrastructure, services, and applications
  - Provisions cloud resources from JavaScript Object Notation (JSON) templates
  - Supports security, auditing, and tagging of cloud resources
- Usage data reporting
  - Provides metering for the cloud
  - Monitors various cloud resources and system components
  - Collects and aggregates the resource usage data across all resource providers
  - Transmits collected data to Azure commerce for billing processing

Microsoft Azure Stack uses Storage Spaces Direct (S2D) unified storage that offers the following features:

- Provides distributed scale-out storage for cloud services and resources
- Scales easily by simply adding more hyperconverged nodes
- Protects from node or drive failures with data redundancy and self-healing

## Lenovo XClarity

Lenovo XClarity offers the following features for the ThinkAgile SX for Microsoft Azure Stack:

- Auto-discovery and monitoring of the management node, hyperconverged nodes, and switches
- Firmware updates and compliance enforcement
- Pattern-based configuration management
- Bare-metal deployment of operating systems and hypervisors
- External alerts and notifications via SNMP traps, syslog remote logging, and e-mail
- Secure connections to managed endpoints
- NIST 800-131A or FIPS 140-2 compliant cryptographic standards between the management solution and managed endpoints
- Integration into existing higher level management systems such as cloud automation and orchestration tools through REST APIs, providing extensive external visibility and control over hardware resources
- An intuitive, easy-to-use GUI

## Deployment services

The following Lenovo Professional Services are included with the ThinkAgile SX for Microsoft Azure Stack to get customers up and running quickly:

- Conducting remote preparation and planning
- Verifying firmware versions and performing firmware updates, if needed
- Configuring network switches
- Configuring IMM management settings
- Installing Lenovo XClarity
- Configuring Lenovo XClarity network settings and performing discovery and inventory
- Installing Azure Stack software
- Transferring knowledge
- Developing post-installation documentation

The optional hardware installation services are available from Lenovo Professional Services, including unpacking and inspecting the system on your site, connecting to power and network, verifying operation, and disposing of the packaging.

The following optional professional services are also available for the ThinkAgile SX for Microsoft Azure Stack:

- Health Check Service
- Cloud Strategy and Migration Roadmap
- Cloud TCO Study
- Migration Planning and Design
- Legacy to Cloud Migration
- Hybrid Cloud Managed Services

## Warranty and maintenance

The ThinkAgile SX for Microsoft Azure Stack can be configured with a three-, four, or five-year customer-replaceable unit (CRU) and onsite (for field-replaceable units [FRUs] only) limited hardware warranty with 24x7 ThinkAgile Advantage Single Point of Support (Lenovo hardware and Microsoft Azure Stack software; requires an active Azure Stack software support contract with Microsoft) and various levels of coverage with a well-defined scope of services, including service hours, response time, term of service, and service agreement terms and conditions.

Some regions might have different warranty terms and conditions than the standard warranty. This is due to local business practices or laws in the specific region. Local service teams can assist in explaining region-specific terms when needed. Examples of region-specific warranty terms are second or longer business day parts delivery or parts-only base warranty.

If warranty terms and conditions include onsite labor for repair or replacement of parts, Lenovo will dispatch a service technician to the customer site to perform the replacement. Onsite labor under base warranty is limited to labor for replacement of parts that have been determined to be field-replaceable units (FRUs). Parts that are determined to be customer-replaceable units (CRUs) do not include onsite labor under base warranty.

If warranty terms include parts-only base warranty, Lenovo is responsible for delivering only replacement parts that are under base warranty (including FRUs) that will be sent to a requested location for self-service. Parts-only service does not include a service technician being dispatched onsite. Parts must be changed at customer's own cost and labor and defective parts must be returned following the instructions supplied with the spares parts.

Lenovo warranty service coverage levels are region-specific. Not all warranty service levels are available in every region. For information about Lenovo warranty services that are available in your region, refer to the following resources:

- Service part numbers in Lenovo Data Center Solution Configurator (DCSC):  
<http://dcsc.lenovo.com/#/services>
- Lenovo Services Availability Locator  
<https://lenovocator.com/>

In general, the following Lenovo hardware warranty service levels are available for the ThinkAgile SX for Microsoft Azure Stack:

- 3, 4, or 5 years of warranty service coverage with 1-year or 2-year post-warranty extensions:
  - Base warranty: 9x5 Next Business Day response with parts delivered
  - Foundation Service: 9x5 service coverage with next business day onsite response
  - Essential Service: 24x7 service coverage with 4-hour onsite response or 24-hour committed repair (available only in select regions)
  - Advanced Service: 24x7 service coverage with 2-hour onsite response or 6-hour committed repair (available only in select regions)
- Premier Support  
Premier Support service offers direct access to Lenovo's most advanced technicians for faster troubleshooting with single point of contact for end-to-end problem resolution and collaborative third-party software support.
- YourDrive YourData  
Lenovo's YourDrive YourData service is a multi-drive retention offering that ensures your data is always under your control, regardless of the number of drives that are installed in your Lenovo system. In the unlikely event of a drive failure, you retain possession of your drive while Lenovo replaces the failed drive part. Your data stays safely on your premises, in your hands. The YourDrive YourData service can be purchased in convenient bundles with Foundation, Essential, or Advanced Service upgrades and extensions.

For service definitions, region-specific details, and service limitations, please refer to the following documents:

- Lenovo Statement of Limited Warranty for Infrastructure Solutions Group (ISG) Servers and System Storage  
<http://pcsupport.lenovo.com/us/en/solutions/ht503310>
- Lenovo Data Center Services Agreement  
<http://support.lenovo.com/us/en/solutions/ht116628>

A Microsoft Azure Stack subscription and software support contract for ThinkAgile SX for Microsoft Azure Stack should be obtained from Microsoft by the customer.

## Physical specifications

The ThinkAgile SXM4200 25U model has the following dimensions and weight (approximate):

- Height: 1244 mm (49.0 in)
- Width: 605 mm (23.8 in)
- Depth: 1000 mm (39.4 in)
- Total rack load capacity: 570 kg (1256.6 lb)
- Total rack weight (maximum): 670 kg (1477.1 lb)

The ThinkAgile SXM4200 42U and SXM6200 models have the following dimensions and weight (approximate):

- Height: 2009 mm (79.1 in)
- Width: 600 mm (23.6 in)
- Depth: 1096 mm (43.1 in)
- Total rack load capacity: 953 kg (2101 lb)
- Total rack weight (maximum): 1127 kg (2484.6 lb)

## Operating environment

The ThinkAgile SX for Microsoft Azure Stack models are supported in the following environment:

- Air temperature: 5 °C - 40 °C (41 °F - 104 °F)
- Humidity: 10% to 85% (non-condensing)
- Power load (rated maximum):
  - SXM4200 25U (fully configured solution): 10113 W
  - SXM4200 42U / SXM6200 (fully configured solution): 14273 W
  - Solution components:
    - x3550 M5: 873 W
    - x3650 M5: 1040 W
    - G8052: 200 W
    - G8272: 360 W
- Heat output (maximum):
  - SXM4200 25U (fully configured solution): 34093 BTU/hour
  - SXM4200 42U / SXM6200 (fully configured solution): 48285 BTU/hour
  - Solution components:
    - x3550 M5: 2978 BTU/hour
    - x3650 M5: 3548 BTU/hour
    - G8052: 683 BTU/hour
    - G8272: 1024 BTU/hour

## Related publications and links

For more information, see these resources:

- Lenovo ThinkAgile SX for Microsoft Azure Stack home page  
<http://www3.lenovo.com/us/en/p/WMD00000272>
- Lenovo Data Center Solution Configurator (DCSC):  
<http://dcsc.lenovo.com>
- Lenovo ThinkAgile Documentation  
[http://thinkagile.lenovofiles.com/help/topic/com.lenovo.thinkagile.sxm.doc/sxm\\_introduction.html](http://thinkagile.lenovofiles.com/help/topic/com.lenovo.thinkagile.sxm.doc/sxm_introduction.html)

## Related product families

Product families related to this document are the following:

- [Hyperconverged Infrastructure](#)
- [Microsoft Alliance](#)
- [ThinkAgile SXM Series for Microsoft Azure Stack Hub](#)



## Notices

Lenovo may not offer the products, services, or features discussed in this document in all countries. Consult your local Lenovo representative for information on the products and services currently available in your area. Any reference to a Lenovo product, program, or service is not intended to state or imply that only that Lenovo product, program, or service may be used. Any functionally equivalent product, program, or service that does not infringe any Lenovo intellectual property right may be used instead. However, it is the user's responsibility to evaluate and verify the operation of any other product, program, or service. Lenovo may have patents or pending patent applications covering subject matter described in this document. The furnishing of this document does not give you any license to these patents. You can send license inquiries, in writing, to:

Lenovo (United States), Inc.  
8001 Development Drive  
Morrisville, NC 27560  
U.S.A.  
Attention: Lenovo Director of Licensing

LENOVO PROVIDES THIS PUBLICATION "AS IS" WITHOUT WARRANTY OF ANY KIND, EITHER EXPRESS OR IMPLIED, INCLUDING, BUT NOT LIMITED TO, THE IMPLIED WARRANTIES OF NON-INFRINGEMENT, MERCHANTABILITY OR FITNESS FOR A PARTICULAR PURPOSE. Some jurisdictions do not allow disclaimer of express or implied warranties in certain transactions, therefore, this statement may not apply to you.

This information could include technical inaccuracies or typographical errors. Changes are periodically made to the information herein; these changes will be incorporated in new editions of the publication. Lenovo may make improvements and/or changes in the product(s) and/or the program(s) described in this publication at any time without notice.

The products described in this document are not intended for use in implantation or other life support applications where malfunction may result in injury or death to persons. The information contained in this document does not affect or change Lenovo product specifications or warranties. Nothing in this document shall operate as an express or implied license or indemnity under the intellectual property rights of Lenovo or third parties. All information contained in this document was obtained in specific environments and is presented as an illustration. The result obtained in other operating environments may vary. Lenovo may use or distribute any of the information you supply in any way it believes appropriate without incurring any obligation to you.

Any references in this publication to non-Lenovo Web sites are provided for convenience only and do not in any manner serve as an endorsement of those Web sites. The materials at those Web sites are not part of the materials for this Lenovo product, and use of those Web sites is at your own risk. Any performance data contained herein was determined in a controlled environment. Therefore, the result obtained in other operating environments may vary significantly. Some measurements may have been made on development-level systems and there is no guarantee that these measurements will be the same on generally available systems. Furthermore, some measurements may have been estimated through extrapolation. Actual results may vary. Users of this document should verify the applicable data for their specific environment.

© Copyright Lenovo 2025. All rights reserved.

This document, LP0603, was created or updated on August 28, 2018.

Send us your comments in one of the following ways:

- Use the online Contact us review form found at:  
<https://lenovopress.lenovo.com/LP0603>
- Send your comments in an e-mail to:  
[comments@lenovopress.com](mailto:comments@lenovopress.com)

This document is available online at <https://lenovopress.lenovo.com/LP0603>.

## Trademarks

Lenovo and the Lenovo logo are trademarks or registered trademarks of Lenovo in the United States, other countries, or both. A current list of Lenovo trademarks is available on the Web at <https://www.lenovo.com/us/en/legal/copytrade/>.

The following terms are trademarks of Lenovo in the United States, other countries, or both:

Lenovo®

System x®

ThinkAgile®

ThinkSystem®

XClarity®

The following terms are trademarks of other companies:

Intel® and Xeon® are trademarks of Intel Corporation or its subsidiaries.

Microsoft®, Active Directory®, Azure®, Hyper-V®, Windows Server®, and Windows® are trademarks of Microsoft Corporation in the United States, other countries, or both.

Other company, product, or service names may be trademarks or service marks of others.