

Lenovo ThinkSystem SN850 Server (Xeon SP Gen 1) Product Guide (withdrawn product)

The Lenovo ThinkSystem SN850 is a high-performance server that offers enhanced security, efficiency, and reliability features to handle business-critical workloads. The blade server incorporates up to four Intel Xeon Processor Scalable Family of processors. The processors feature up to 28 cores each and use Lenovo TruDDR4 memory, which runs at speeds up to 2666 MHz.

Suggested uses: large database, virtualization, enterprise applications, HPC, and cloud applications.

Figure 1 shows the ThinkSystem SN850 server



Figure 1. ThinkSystem SN850 server

Did you know?

The SN850 server uses Intel Xeon Scalable Gold and Platinum processors and memory can now operate at speeds up to 2666 MHz. It also includes the next generation UEFI-based Lenovo XClarity Provisioning Manager for rapid system setup and diagnosis, and Lenovo XClarity Controller management processor for systems management and alerting.

Key features

This section describes the key features of the server.

Scalability and performance

The SN850 offers the following features to boost performance, improve scalability, and reduce costs:

- Up to 7 SN850 servers can be installed in one Flex System Enterprise chassis.
- Improves productivity by offering superior system performance with up to 28-core processors, 38.5 MB of L3 cache, up to three 10.4 GT/s Ultra Path Interconnect links and a Thermal Design Power (TDP) rating of up to 165W.
- Supports up to four processors, 112 cores, and 224 threads, which maximizes the concurrent execution of multi-threaded applications. When four processors are installed, they are connected in a Mesh topology to maximize inter-processor communication (requires processors with three UPI connections)
- Intelligent and adaptive system performance with energy-efficient Intel Turbo Boost Technology allows CPU cores to run at maximum speeds during peak workloads by temporarily going beyond processor TDP.
- Intel Hyper-Threading Technology boosts performance for multithreaded applications by enabling simultaneous multithreading within each processor core, up to two threads per core.
- Intel Virtualization Technology integrates hardware-level virtualization hooks that allow operating system vendors to better use the hardware for virtualization workloads.
- Intel Advanced Vector Extensions 512 (AVX-512) enable acceleration of enterprise-class workloads, such as databases and enterprise resource planning.
- Each processor has 6 memory channels with up to 2 two DIMMs per channel running at up to 2666 MHz.
- Up to 3.0 TB using 48x 64 GB LRDIMMs (all processors) or 6.0 TB using 48x 128 GB 3DS RDIMMs (requires M-suffix processors).
- Optional support for high-performance PCIe-attached NVMe Flash Storage solid-state drives (SSDs) can significantly improve I/O performance.
- Embedded 4-port 10Gb Intel adapter built into the system board is based on the Intel Ethernet Connection X722 network controller.
- With Intel Integrated I/O Technology, the PCI Express 3.0 controller is integrated into the Intel Xeon processor Scalable family. This integration helps to dramatically reduce I/O latency and increase overall system performance.
- Support for high-bandwidth I/O adapters; up to four in each SN850 server.
- Support for 40 Gb Ethernet, 16 Gb Fibre Channel, and FDR InfiniBand.
- High-speed USB 3.0 port for connectivity to external devices.

Availability and serviceability

The SN850 provides the following features to simplify serviceability and increase system up-time:

- The server offers Single Device Data Correction (SDDC, also known as Chipkill), Adaptive Double- Device Data Correction (ADDDC, also known as Redundant Bit Steering or RBS), memory mirroring, and memory rank sparing for redundancy in the event of a non-correctable memory failure.
- Tool-less cover removal provides easy access to upgrades and serviceable parts, such as CPU, memory, and adapter cards.
- The Dual M.2 Boot Adapter supports RAID-1 which enables two installed M.2 drives to be configured as a redundant pair.
- Hot-swap drives support integrated RAID-1 redundancy for data protection and greater system up-time.
- Solid-state drives (SSDs), which offer significantly better reliability than mechanical HDDs for greater uptime.
- The power source independent light path diagnostics functionality provides individual LEDs that lead the technician to failed (or failing) components, which simplifies servicing, speeds up problem resolution, and helps improve system availability.

- The built-in XClarity Controller continuously monitors system parameters, triggers alerts, and performs recovery actions in case of failures to minimize downtime.
- Proactive Platform Alerts (including PFA and SMART alerts): Processors, voltage regulators, memory, internal storage (SAS/SATA HDDs and SSDs, NVMe SSDs, flash storage adapters), RAID controllers, and server ambient and sub-component temperatures. Alerts can be surfaced through the system XClarity Controller to managers such as Lenovo XClarity Administrator, VMware vCenter, and Microsoft System Center. These proactive alerts let you take appropriate actions in advance of possible failure, thereby increasing server uptime and application availability.
- Built-in diagnostics in UEFI, using Lenovo XClarity Provisioning Manager, speed up troubleshooting tasks to reduce service time, and supports diagnostic function and to collect service data to USB key drive or remote CIFS share folder.
- Auto-restart in the event of a momentary loss of AC power (based on power policy setting in the XClarity Controller service processor).
- Support for the XClarity Administrator Mobile app running on a supported smartphone and connected to the server through the service-enabled USB port, enables additional local systems management functions.
- Three-year customer replaceable unit and on-site limited warranty; next business day 9x5. Optional service upgrades are available.

Manageability and security

The following powerful systems management features simplify the local and remote management of the SN850:

- Support for Lenovo XClarity Administrator, providing auto-discovery, inventory tracking, monitoring, policy-based firmware updates, address pool management, configuration patterns and operating system installation.
- The server includes an XClarity Controller (XCC) to monitor server availability and perform remote management. XCC Advanced is supported as standard, which enables remote KVM, mounting of remote media files (ISO and IMG image files), boot capture, and power capping.
- UEFI-based Lenovo XClarity Provisioning Manager, accessible from F1 during boot, provides system inventory information, graphical UEFI Setup, platform update function, RAID Setup wizard, operating system installation function, and diagnostic functions
- Integrated Trusted Platform Module (TPM) 2.0 support enables advanced cryptographic functionality, such as digital signatures and remote attestation.
- Supports Secure Boot to ensure only a digitally signed operating system can be used. Supported with HDDs and SSDs as well as M.2 drives.
- Support for Lenovo XClarity Energy Manager which captures real-time power and temperature data from the server and provides automated controls to lower energy costs.
- Industry-standard Advanced Encryption Standard (AES) NI support for faster, stronger encryption.
- Intel Execute Disable Bit functionality can help prevent certain classes of malicious buffer overflow attacks when combined with a supporting operating system.
- Intel Trusted Execution Technology provides enhanced security through hardware-based resistance to malicious software attacks, which allows an application to run in its own isolated space that is protected from all other software that is running on a system.

Energy efficiency

The SN850 offers the following energy-efficiency features to save energy, reduce operational costs, increase energy availability, and contribute to a green environment:

- The component-sharing design of the Flex System chassis provides ultimate power and cooling savings.
- The Intel Xeon Processor Scalable Family of processors offer significantly better performance than previous generations of processors, while fitting into the same TDP limits.
- Intel Intelligent Power Capability powers individual processor elements on and off as needed, which reduces power draw.
- Solid state drives (SSDs) use as much as 80% less power than traditional spinning 2.5-inch HDDs.
- The SN850 uses hexagonal ventilation holes which can be grouped more densely than round holes, providing more efficient airflow through the system.

Locations of key components and connectors

Figure 2 shows the front of the server.

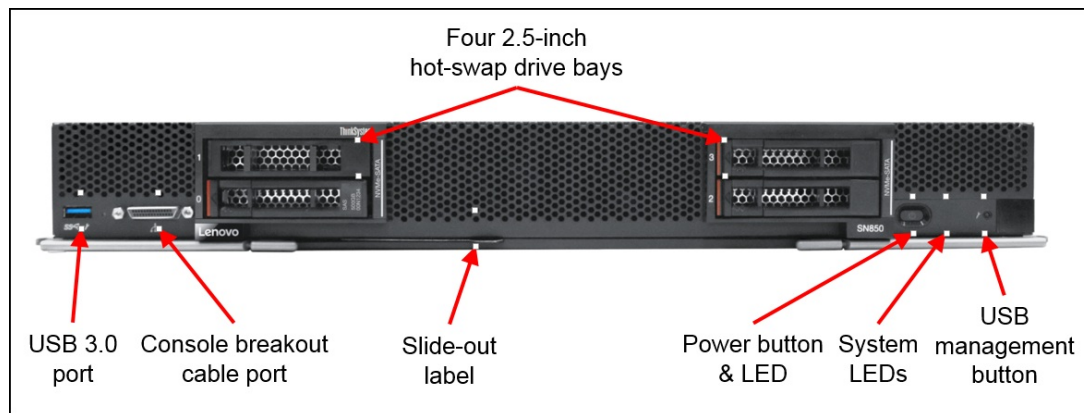

Figure 2. Front view of the SN850 server

Figure 3 shows the locations of key components inside the server.

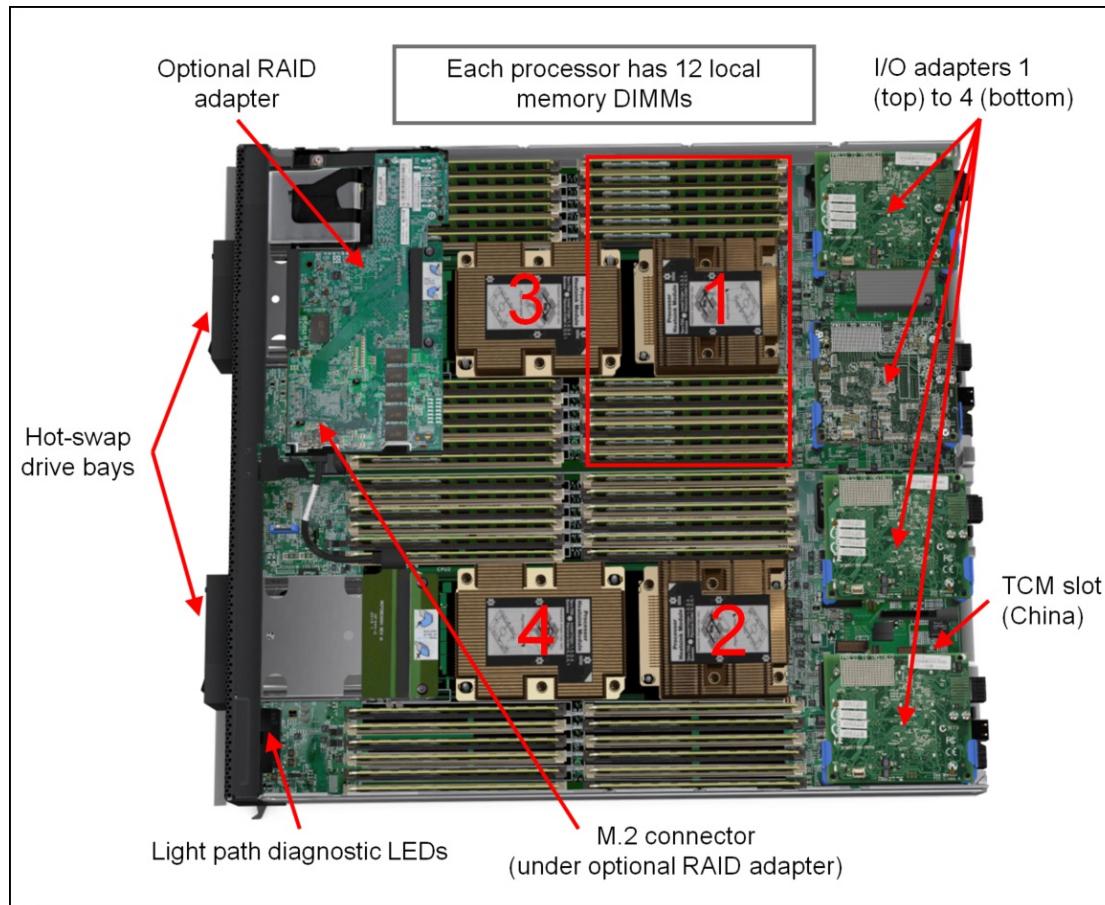

Figure 3. Inside view of the SN850 server

System architecture

The following figure shows the architectural block diagram of the SN850, showing the major components and their connections.

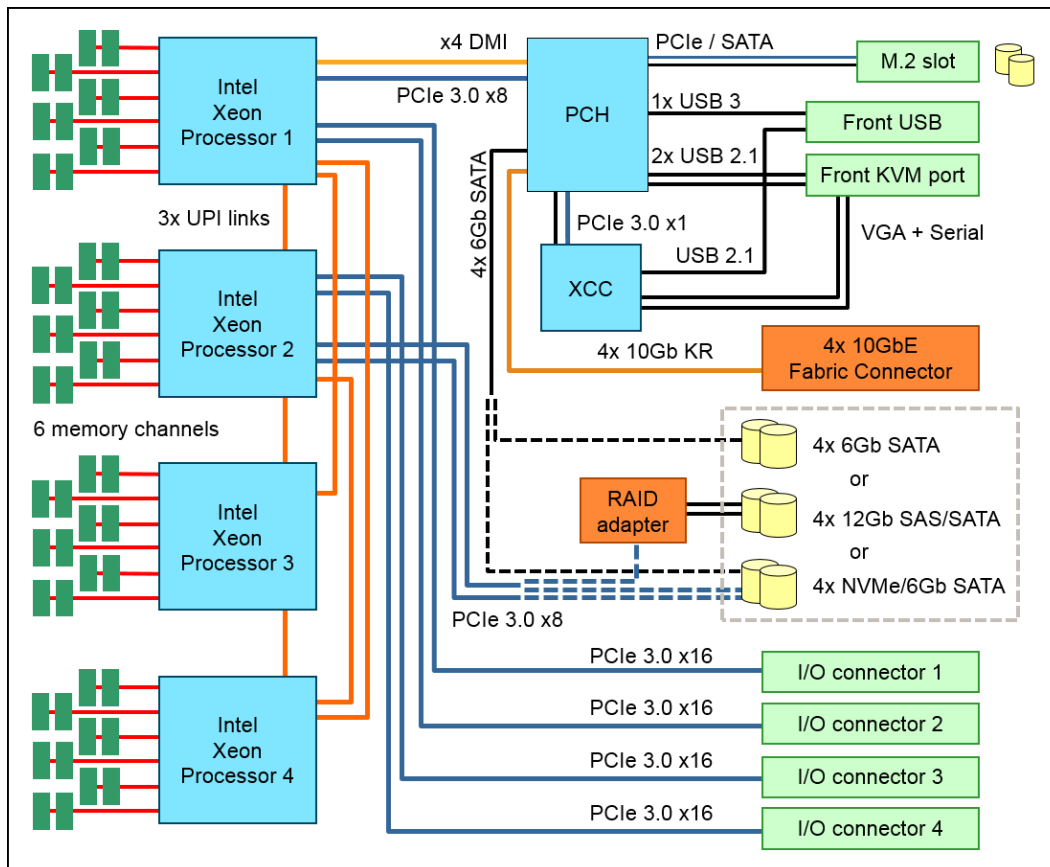

Figure 4. SN850 system architectural block diagram

Standard specifications

The following table lists the standard specifications.

Table 1. Standard specifications

Components	Specification
Machine Type	7X15
Form factor	Double-width Flex System compute node.
Chassis support	Flex System Enterprise Chassis with CMM2.
Processor	Up to four Intel Xeon processor Scalable product family CPUs: from 4 cores to 28 cores; core speeds from 1.7 GHz to 3.6 GHz; up to 38.5 MB L3 cache. Up to 3 UPI links with up to 10.4 GT/s each (processor dependent). Up to 2666 MHz memory speed.
Chipset	Intel C624

Components	Specification
Memory	Up to 48 DIMM sockets (12 DIMMs on 6 channels per processor) supporting Lenovo TruDDR4 DIMMs at up to 2666 MHz. RDIMMs, LRDIMMs and 3DS RDIMMs are supported, but memory types cannot be intermixed.
Memory maximums	With RDIMMs: Up to 1.5 TB with 48x 32 GB RDIMMs and four CPUs With LRDIMMs: Up to 3 TB with 48x 64 GB LRDIMMs and four CPUs With 3DS RDIMMs: Up to 6 TB with 48x 128 GB 3DS RDIMMs and four CPUs (requires M-suffix processors that support greater than 786 GB memory per processor)
Memory protection	ECC, SDDC (for x4-based memory DIMMs), ADDDC (for x4-based memory DIMMs, requires Intel Xeon Gold or Platinum processors), memory mirroring, and memory sparing.
Disk drive bays	Four 2.5-inch hot-swap SAS/SATA drive bays that support SAS, SATA, and SSDs. Optional support for four 2.5-inch NVMe PCIe SSDs.
Maximum internal storage	<ul style="list-style-type: none"> • 61.44TB using 4x 15.36TB 2.5-inch SAS SSDs • 30.72TB using 4x 7.68TB 2.5-inch NVMe SSDs • 9.6TB using 4x 2.4TB 2.5-inch HDDs • No support for the Flex System Storage Expansion Node
RAID support	RAID-0, RAID-1, RAID-5 and RAID-10 with integrated Intel RSTe controller and optional Basic RAID 530-4i controller; RAID-0, RAID-1, RAID-5, RAID-6 and RAID-10 with optional Advanced RAID 930-4i controller.
Network interfaces	Integrated Intel 10 GbE; optional 1 Gb, 10 GbE, or 40 GbE adapters.
PCI Expansion slots	Four I/O connectors for adapters. PCI Express 3.0 x16 interface. No support for the Flex System PCIe Expansion Node.
Ports	Front: One USB 3.0 port and one console breakout cable port that provides local KVM and serial ports (cable standard with chassis; more cables optional).
Systems management	UEFI, Lenovo XClarity Controller with Pilot4 XE401 baseboard management controller (BMC), Predictive Failure Analysis, light path diagnostics panel, automatic server restart, remote presence. Support for Lenovo XClarity Administrator and Lenovo XClarity Energy Manager.
Security features	Power-on password, administrator's password, Trusted Platform Module (TPM) 1.2 and 2.0, Trusted Cryptographic Module (TCM) - China only.
Video	G200 graphics with 16 MB memory and 2D hardware accelerator, integrated into the XClarity Controller. Maximum resolution is 1920x1200 32bpp at 60Hz.
Limited warranty	Three-year customer-replaceable unit and on-site limited warranty with 9x5/NBD.
Operating systems supported	Microsoft Windows Server, Red Hat Enterprise Linux, SUSE Linux Enterprise Server, VMware ESXi. See the Operating system support section for specifics.
Service and support	Optional service upgrades are available through Lenovo Services: 4-hour or 2-hour response time, 6-hour fix time, 1-year or 2-year warranty extension, software support for Lenovo hardware and some third-party applications.
Dimensions	Width: 435 mm (17.1 inches), height 55 mm (2.2 inches), depth 493 mm (19.4 inches).
Weight	Maximum configuration: 12.3 kg (27 lb).

The SN850 server is shipped with the following items:

- Statement of Limited Warranty
- Important Notices

Chassis support

The SN850 server is supported in the Flex System chassis as listed in the following table.

Table 2. Chassis support

Chassis models	Description	Supports SN850
8721-HC1 based: 8721-A1x, LRx, DCx 8721-K1G, E1Y, E2Y	Lenovo Flex System Enterprise Chassis with CMM (68Y7030) standard	No
8721-HC2 based: 8721-ALx, DLx 8721-E3Y, E4Y	Lenovo Flex System Enterprise Chassis with CMM2 (00FJ669) standard	Yes
7385-DCx	Lenovo Flex System Carrier-Grade Chassis	No

Note: CMM2 firmware should be 1.6.1 or later to support ThinkSystem compute nodes

Up to seven SN850 servers can be installed in the chassis; however, the actual number that can be installed in a chassis depends on the following factors:

- TDP power rating for the processors that are installed in the SN850
- Number of power supplies that are installed in the chassis
- Capacity of the installed power supplies (2100 W or 2500 W)
- Chassis power redundancy policy that is used (N+1 or N+N)
- Node throttling is allowed

The following table provides guidelines about what number of SN850 servers can be installed. For more information, use Lenovo Capacity Planner, which is found at the following web page:

<https://datacentersupport.lenovo.com/us/en/products/solutions-and-software/software/lenovo-capacity-planner/solutions/ht504651>

The following color coding was used in the table:

- Green = No restriction on the number of SN850 servers that can be installed
- Yellow = Some bays must be left empty in the chassis

Table 3. Maximum number of SN850 servers that can be installed based on input voltage and power redundancy policy used (2500 W power supply)

SN850 CPU TDP rating	With 208V AC supply (2500 W power output)					With 220V or higher AC supply (2745 W power output)				
	N+1, N=5, 6 power supplies, without throttle	N+1, N=4, 5 power supplies, with throttling	N+1, N=3, 4 power supplies, with throttling	N+N, N=3, 6 power supplies, with throttling	N+N, N=3, 6 power supplies, without throttle	N+1, N=5, 6 power supplies, without throttle	N+1, N=4, 5 power supplies, without throttle	N+1, N=3, 4 power supplies, with throttling	N+N, N=3, 6 power supplies, with throttling	N+N, N=3, 6 power supplies, without throttle
85 W	7	7	7	7	6	7	7	7	7	6
105 W	7	7	7	7	5	7	7	7	7	6
125 W	7	7	7	7	5	7	7	7	7	5
130 W	7	7	7	7	5	7	7	7	7	5
140 W	7	7	6	7	4	7	7	7	7	5
150 W	7	7	6	7	4	7	7	7	7	5
165 W	7	7	6	6	4	7	7	7	7	4

Processor options

The SN850 supports the Intel Xeon Processor Scalable Family options that are listed in the following table. The server supports two or four processors. When four processors are installed, they are connected in the Mesh topology to maximize inter-processor communication (requires processors with three UPI connections).

All supported processors have the following characteristics:

- 14 nm process technology
- Six DDR4 memory channels
- 48 PCIe 3.0 I/O lanes
- 1 MB L2 cache
- 1.375 MB L3 cache per core (except where larger, as noted with ** in the table below)
- Intel Hyper-Threading Technology
- Intel Turbo Boost Technology 2.0
- Intel Advanced Vector Extensions 512 (AVX-512)
- Intel Ultra Path Interconnect (UPI) links at 10.4 GT/s (replaces QPI)

Depending on the processor model installed, the processors are connected together using either two or three UPI links. Processors with a T suffix are those that have more robust thermal characteristics (higher T-case). Processors with an M suffix support support greater than 768 GB per processor.

Note: The SN850 processor part numbers listed include two processors.

Table 4. SN850 processor options

Part number	Feature code	Intel Xeon processor	Memory speed	Supports >768 GB per CPU	L3 cache**	AVX-512 FMA units*	UPI Links
7XG7A06281	AX8M	Xeon Gold 5115 10C 85W 2.4GHz	2400 MHz	No	13.75 MB	1	2
4XG7A09155	B13A	Xeon Gold 5117 14C 105W 2.0GHz	2400 MHz	No	19.25 MB	1	2
7XG7A06282	AX7D	Xeon Gold 5118 12C 105W 2.3GHz	2400 MHz	No	16.5 MB	1	2
4XG7A09154	AX7F	Xeon Gold 5119T 14C 85W 1.9GHz	2400 MHz	No	19.25 MB	1	2
7XG7A06284	AX7C	Xeon Gold 5120 14C 105W 2.2GHz	2400 MHz	No	19.25 MB	1	2
7XG7A06283	AX7E	Xeon Gold 5120T 14C 105W 2.2GHz	2400 MHz	No	19.25 MB	1	2
7XG7A06270	AX70	Xeon Gold 5122 4C 105W 3.6GHz	2666 MHz*	No	16.5 MB**	2*	2
7XG7A06268	AWEX	Xeon Gold 6126 12C 125W 2.6GHz	2666 MHz	No	19.25 MB**	2	3
4XG7A37098	AX73	Xeon Gold 6126T 12C 125W 2.6GHz	2666 MHz	No	19.25 MB**	2	3
4XG7A09152	AX6Z	Xeon Gold 6128 6C 115W 3.4GHz	2666 MHz	No	19.25 MB**	2	3
7XG7A06265	AX6D	Xeon Gold 6130 16C 125W 2.1GHz	2666 MHz	No	22 MB	2	3
7XG7A06263	AX72	Xeon Gold 6130T 16C 125W 2.1GHz	2666 MHz	No	22 MB	2	3
4XG7A09151	AX6U	Xeon Gold 6132 14C 140W 2.6GHz	2666 MHz	No	19.25 MB	2	3
7XG7A06269	AX6Y	Xeon Gold 6134 8C 130W 3.2GHz	2666 MHz	No	24.75 MB**	2	3
4XG7A09150	AX7A	Xeon Gold 6134M 8C 130W 3.2GHz	2666 MHz	Yes	24.75 MB**	2	3
7XG7A06267	AX6W	Xeon Gold 6136 12C 150W 3.0GHz	2666 MHz	No	24.75 MB**	2	3

Part number	Feature code	Intel Xeon processor	Memory speed	Supports >768 GB per CPU	L3 cache**	AVX-512 FMA units*	UPI Links
7XG7A06260	AX6Q	Xeon Gold 6138 20C 125W 2.0GHz	2666 MHz	No	27.5 MB	2	3
4XG7A09153	AX71	Xeon Gold 6138T 20C 125W 2.0GHz	2666 MHz	No	27.5 MB	2	3
7XG7A06262	AX6R	Xeon Gold 6140 18C 140W 2.3GHz	2666 MHz	No	24.75 MB	2	3
4XG7A09149	AX79	Xeon Gold 6140M 18C 140W 2.3GHz	2666 MHz	Yes	24.75 MB	2	3
7XG7A06264	AX6E	Xeon Gold 6142 16C 150W 2.6GHz	2666 MHz	No	22 MB	2	3
4XG7A09148	AX78	Xeon Gold 6142M 16C 150W 2.6GHz	2666 MHz	Yes	22 MB	2	3
4XG7A37095	AX6X	Xeon Gold 6144 8C 150W 3.5GHz	2666 MHz	No	24.75 MB**	2	3
4XG7A37096	AX6V	Xeon Gold 6146 12C 165W 3.2GHz	2666 MHz	No	24.75 MB**	2	3
7XG7A06277	AWEW	Xeon Gold 6148 20C 150W 2.4GHz	2666 MHz	No	27.5 MB	2	3
7XG7A06261	AX6T	Xeon Gold 6150 18C 165W 2.7GHz	2666 MHz	No	24.75 MB	2	3
7XG7A06259	AX6P	Xeon Gold 6152 22C 140W 2.1GHz	2666 MHz	No	30.25 MB	2	3
7XG7A06266	AX6L	Xeon Platinum 8153 16C 125W 2.0GHz	2666 MHz	No	22 MB	2	3
7XG7A06280	AWEV	Xeon Platinum 8156 4C 105W 3.6GHz	2666 MHz	No	16.5 MB**	2	3
7XG7A06279	AX7B	Xeon Platinum 8158 12C 150W 3.0GHz	2666 MHz	No	24.75 MB**	2	3
7XG7A06258	AWGJ	Xeon Platinum 8160 24C 150W 2.1GHz	2666 MHz	No	33 MB	2	3
4XG7A09147	AX77	Xeon Platinum 8160M 24C 150W 2.1GHz	2666 MHz	Yes	33.0 MB	2	3
4XG7A37097	AX6N	Xeon Platinum 8160T 24C 150W 2.1GHz	2666 MHz	No	33.0 MB	2	3
7XG7A06257	AX6K	Xeon Platinum 8164 26C 150W 2.0GHz	2666 MHz	No	35.75 MB	2	3
7XG7A06256	AX6J	Xeon Platinum 8170 26C 165W 2.1GHz	2666 MHz	No	35.75 MB	2	3
4XG7A09146	AX76	Xeon Platinum 8170M 26C 165W 2.1GHz	2666 MHz	Yes	35.75 MB	2	3
7XG7A06255	AX6H	Xeon Platinum 8176 28C 165W 2.1GHz	2666 MHz	No	38.5 MB	2	3
4XG7A09145	AX75	Xeon Platinum 8176M 28C 165W 2.1GHz	2666 MHz	Yes	38.5 MB	2	3

* All Gold 5000-level processors, except the 5122, support 2400 MHz memory speeds and have one AVX-512 512-bit FMA units. The 5122 processor supports 2666 MHz and has two FMA units

** L3 cache is 1.375 MB per core except with the processor indicated with ** where the cache size is larger

† Only available as a special order. Please contact your Lenovo representative for details.

Memory options

The SN850 uses Lenovo TruDDR4 memory operating at speeds up to 2666 MHz.

TruDDR4 Memory uses the highest quality components that are sourced from Tier 1 DRAM suppliers and only memory that meets the strict requirements of Lenovo is selected. It is compatibility tested and tuned on every ThinkSystem server to maximize performance and reliability. TruDDR4 Memory has a unique signature that is programmed into the DIMM that enables ThinkSystem servers to verify whether the memory that is installed is qualified and supported by Lenovo.

From a service and support standpoint, Lenovo TruDDR4 memory automatically assumes the Lenovo system warranty and Lenovo provides service and support worldwide.

All DIMMs operate at a speed of 2666 MHz, both at 1 DIMM per channel and 2 DIMMs per channel. However, if the processor selected has a lower memory bus speed (eg 2400 MHz), then all DIMMs will operate at that lower speed.

The following table lists the memory options that are available for the SN850 server.

Table 5. Memory options

Part number	Feature code	Description	Maximum supported
RDIMMs			
7X77A01301	AUU1	ThinkSystem 8GB TruDDR4 2666 MHz (1Rx8 1.2V) RDIMM	48 (12 per processor)
7X77A01302	AUNB	ThinkSystem 16GB TruDDR4 2666 MHz (1Rx4 1.2V) RDIMM	48 (12 per processor)
7X77A01303	AUNC	ThinkSystem 16GB TruDDR4 2666 MHz (2Rx8 1.2V) RDIMM	48 (12 per processor)
7X77A01304	AUND	ThinkSystem 32GB TruDDR4 2666 MHz (2Rx4 1.2V) RDIMM	48 (12 per processor)
LRDIMMs			
7X77A01305	AUNE	ThinkSystem 64GB TruDDR4 2666 MHz (4Rx4 1.2V) LRDIMM	48 (12 per processor)
3DS RDIMMs			
7X77A01307	AUNF	ThinkSystem 128GB TruDDR4 2666 MHz (8Rx4 1.2V) 3DS RDIMM	48 (12 per processor)

The following rules apply when selecting the memory configuration:

- The server supports RDIMMs, LRDIMMs and 3DS RDIMMs. UDIMMs are not supported.
- Mixing RDIMMs and LRDIMMs is not supported.
- Mixing 3DS RDIMMs with either RDIMMs or LRDIMMs is not supported.
- Mixing x4 and x8 DIMMs is supported.
- For best performance, populate memory DIMMs in quantities of 6 or 12 per processor, so that all memory channels are used.

The following memory protection technologies are supported:

- ECC
- SDDC (for x4-based memory DIMMs; look for "x4" in the DIMM description)
- ADDDC (for x4-based memory DIMMs; Gold and Platinum processors only)
- Memory channel mirroring
- Memory rank sparing

If memory channel mirroring is used, then DIMMs must be installed in pairs or sets of three (minimum of one pair or set of three per processor), and all DIMMs in the pair or set of three must be identical in type and size. 50% of the installed capacity is available to the operating system

If memory rank sparing is used, then a minimum of one quad-rank DIMM or two single-rank or dual-rank DIMMs must be installed per populated channel (the DIMMs do not need to be identical). In rank sparing mode, one rank of a DIMM in each populated channel is reserved as spare memory. The largest rank in the channel will be automatically selected as the spare rank. The amount of memory available to the operating system depends on the number, capacity and rank counts of the DIMMs installed.

Internal storage

The SN850 server has four 2.5-inch hot-swap drive bays that are accessible from the front of the blade server (see [Figure 2](#)). Depending on server configuration and installed backplanes, these bays connect to either the integrated 6 Gbps SATA controller, optional Lenovo RAID controllers or directly to PCIe lanes for NVMe drives.

In addition, the SN850 can also support one or two M.2 form factor SSD drives on a separate adapter. The following table lists the supported M.2 adapters (enablement kits). For more information, see the ThinkSystem M.2 Drives and M.2 Adapters product guide: <https://lenovopress.com/lp0769-thinksystem-m2-drives-adapters>

Virtualization support: The integrated SATA controller can be used with virtualization hypervisors, including VMware ESXi, Linux KVM, Xen, and Microsoft Hyper-V. However, support is limited to AHCI (non-RAID) mode. RSTe mode is not supported with virtualization hypervisors.

Storage backplane kits, RAID and M.2 upgrades are listed below.

Table 6. Internal storage upgrades

Part number	Feature code	Name and description	Drive types supported	Maximum supported
7M17A03930	AVEA	ThinkSystem SATA Backplane kit for SN850 (includes 2 backplanes)	4x SATA	1
7M17A03931	AVEB	ThinkSystem NVMe/SATA Backplane Kit for SN850 (includes 2 backplanes)	4x NVMe or 4x SATA or combination	1
7M17A03933	AVED	ThinkSystem RAID 930-4i-2GB 4 Drive Adapter Kit for SN850 (includes RAID adapter, 2 backplanes and interposer)	4x SATA or 4x SAS or combination	1
7M17A03932	AVEC	ThinkSystem RAID 530-4i 4 Drive Adapter Kit for SN850 (includes RAID adapter, 2 backplanes and interposer)	4x SATA or 4x SAS or combination	1
7Y37A01092	AUMU	ThinkSystem M.2 Enablement Kit	1x M.2	1
7Y37A01093	AUMV	ThinkSystem M.2 with Mirroring Enablement Kit	2x M.2	1

Supported drives are listed in the [Internal drive options](#) section.

SED encryption key management with SKLM

The server supports self-encrypting drives (SEDs) as listed in the [Internal drive options](#) section. To effectively manage a large deployment of these drives in Lenovo servers, IBM Security Key Lifecycle Manager (SKLM) offers a centralized key management solution.

The IBM Security Key Lifecycle Manager software is available from Lenovo using the ordering information listed in the following table.

Table 7. IBM Security Key Lifecycle Manager licenses

Part number	Feature	Description
SKLM Basic Edition		
7S0A007FWW	S874	IBM Security Key Lifecycle Manager Basic Edition Install License + SW Subscription & Support 12 Months

Part number	Feature	Description
7S0A008VWW	SDJR	IBM Security Key Lifecycle Manager Basic Edition Install License + SW Subscription & 3 Years Of Support
7S0A008WWW	SDJS	IBM Security Key Lifecycle Manager Basic Edition Install License + SW Subscription & 4 Years Of Support
7S0A008XWW	SDJT	IBM Security Key Lifecycle Manager Basic Edition Install License + SW Subscription & 5 Years Of Support
SKLM For Raw Decimal Terabyte Storage		
7S0A007HWW	S876	IBM Security Key Lifecycle Manager For Raw Decimal Terabyte Storage Resource Value Unit License + SW Subscription & Support 12 Months
7S0A008YWW	SDJU	IBM Security Key Lifecycle Manager For Raw Decimal Terabyte Storage Resource Value Unit License + SW Subscription & 3 Years Of Support
7S0A008ZWW	SDJV	IBM Security Key Lifecycle Manager For Raw Decimal Terabyte Storage Resource Value Unit License + SW Subscription & 4 Years Of Support
7S0A0090WW	SDJW	IBM Security Key Lifecycle Manager For Raw Decimal Terabyte Storage Resource Value Unit License + SW Subscription & 5 Years Of Support
SKLM For Raw Decimal Petabyte Storage		
7S0A007KWW	S878	IBM Security Key Lifecycle Manager For Raw Decimal Petabyte Storage Resource Value Unit License + SW Subscription & Support 12 Months
7S0A0091WW	SDJX	IBM Security Key Lifecycle Manager For Raw Decimal Petabyte Storage Resource Value Unit License + SW Subscription & 3 Years Of Support
7S0A0092WW	SDJY	IBM Security Key Lifecycle Manager For Raw Decimal Petabyte Storage Resource Value Unit License + SW Subscription & 4 Years Of Support
7S0A0093WW	SDJZ	IBM Security Key Lifecycle Manager For Raw Decimal Petabyte Storage Resource Value Unit License + SW Subscription & 5 Years Of Support
SKLM For Usable Decimal Terabyte Storage		
7S0A007MWW	S87A	IBM Security Key Lifecycle Manager For Usable Decimal Terabyte Storage Resource Value Unit License + SW Subscription & Support 12 Months
7S0A0094WW	SDK0	IBM Security Key Lifecycle Manager For Usable Decimal Terabyte Storage Resource Value Unit License + SW Subscription & 3 Years In Support
7S0A0095WW	SDK1	IBM Security Key Lifecycle Manager For Usable Decimal Terabyte Storage Resource Value Unit License + SW Subscription & 4 Years In Support
7S0A0096WW	SDK2	IBM Security Key Lifecycle Manager For Usable Decimal Terabyte Storage Resource Value Unit License + SW Subscription & 5 Years In Support
SKLM For Usable Decimal Petabyte Storage		
7S0A007PWW	S87C	IBM Security Key Lifecycle Manager For Usable Decimal Petabyte Storage Resource Value Unit License + SW Subscription & Support 12 Months
7S0A0097WW	SDK3	IBM Security Key Lifecycle Manager For Usable Decimal Petabyte Storage Resource Value Unit License + SW Subscription & 3 Years Of Support
7S0A0098WW	SDK4	IBM Security Key Lifecycle Manager For Usable Decimal Petabyte Storage Resource Value Unit License + SW Subscription & 4 Years Of Support
7S0A0099WW	SDK5	IBM Security Key Lifecycle Manager For Usable Decimal Petabyte Storage Resource Value Unit License + SW Subscription & 5 Years Of Support

Controllers for internal storage

In addition to the optional M.2 RAID-1 enabled adapter, the SN850 supports 3 different RAID controllers as shown in the table below.

Table 8. SN850 RAID controllers with features

Feature	Onboard	RAID 530-4i	RAID 930-4i
Adapter type	Software RAID	RAID controller	RAID controller
Part number	None	7M17A03932	7M17A03933
Form factor	Integrated	Adapter	Adapter
Controller chip	Intel PCH (RSTe)	LSI SAS3404	LSI SAS3504
Host interface	Not applicable	PCIe 3.0x8	PCIe 3.0x8
Port interface	6 Gb SATA	12 Gb SAS	12 Gb SAS
Drive interface	SATA	SAS, SATA	SAS, SATA
Drive type	HDD, SSD	HDD, SED, SSD	HDD, SED, SSD
Hot-swap drives	Yes	Yes	Yes
Max devices	4	4	4
RAID levels	0, 1, 10, 5	0, 1, 10, 5	0, 1, 10, 5, 6
JBOD mode	Yes	Yes	Yes
Cache	No	No	2GB (Standard)
CacheVault cache protection	No	No	Yes (Flash)
Performance Accelerator (FastPath)	No	Yes	Yes
SED support	No	Yes	Yes

Both the 530-4i and 930-4i replace the onboard SATA controller in the server and support high-performance RAID to the four internal 2.5-inch drive bays.

The following figure shows the ThinkSystem RAID 530-4i adapter for the SN850 blade server. Note that the plastic frame in the lower right of the adapter is part of the mechanism that attaches the adapter to the server; this adapter does not support a supercapacitor.

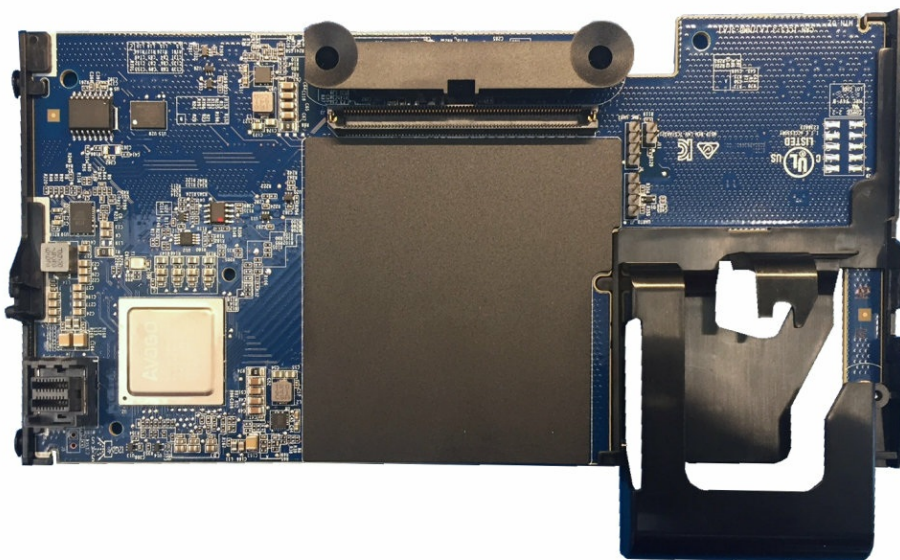

Figure 5. ThinkSystem RAID 530-4i

Both ThinkSystem RAID Adapter kits for SN850 include the following components:

- RAID controller
- Two replacement 2-drive SAS/SATA backplanes
- Interposer cable

Internal drive options

The following tables list the hard disk drive and solid-state drive options for the internal disk storage of the server.

2.5-inch hot-swap drives:

- [2.5-inch hot-swap 12 Gb SAS HDDs](#)
- [2.5-inch hot-swap 6 Gb SATA HDDs](#)
- [2.5-inch hot-swap 12 Gb SAS SSDs](#)
- [2.5-inch hot-swap 6 Gb SATA SSDs](#)
- [2.5-inch hot-swap PCIe 4.0 NVMe SSDs](#)
- [2.5-inch hot-swap PCIe 3.0 NVMe SSDs](#)

M.2 drives:

- [M.2 SATA drives](#)

M.2 drive support: The use of M.2 drives requires an additional adapter as described in the [M.2 drives](#) subsection.

PCIe 4.0 NVMe drive support: When installed in this server, PCIe 4.0 NVMe drives will operate at PCIe 3.0 speeds.

Table 9. 2.5-inch hot-swap 12 Gb SAS HDDs

Part number	Feature	Description	Maximum supported
2.5-inch hot-swap HDDs - 12 Gb SAS 10K			
7XB7A00024	AULY	ThinkSystem 2.5" 300GB 10K SAS 12Gb Hot Swap 512n HDD	4
7XB7A00025	AULZ	ThinkSystem 2.5" 600GB 10K SAS 12Gb Hot Swap 512n HDD	4
7XB7A00026	AUM0	ThinkSystem 2.5" 900GB 10K SAS 12Gb Hot Swap 512n HDD	4
7XB7A00027	AUM1	ThinkSystem 2.5" 1.2TB 10K SAS 12Gb Hot Swap 512n HDD	4
7XB7A00028	AUM2	ThinkSystem 2.5" 1.8TB 10K SAS 12Gb Hot Swap 512e HDD	4
7XB7A00069	B0YS	ThinkSystem 2.5" 2.4TB 10K SAS 12Gb Hot Swap 512e HDD	4
2.5-inch hot-swap HDDs - 12 Gb SAS 15K			
7XB7A00021	AULV	ThinkSystem 2.5" 300GB 15K SAS 12Gb Hot Swap 512n HDD	4
7XB7A00022	AULW	ThinkSystem 2.5" 600GB 15K SAS 12Gb Hot Swap 512n HDD	4
7XB7A00023	AULX	ThinkSystem 2.5" 900GB 15K SAS 12Gb Hot Swap 512e HDD	4
2.5-inch hot-swap HDDs - 12 Gb NL SAS			
7XB7A00034	AUM6	ThinkSystem 2.5" 1TB 7.2K SAS 12Gb Hot Swap 512n HDD	4
7XB7A00035	AUM7	ThinkSystem 2.5" 2TB 7.2K SAS 12Gb Hot Swap 512n HDD	4
2.5-inch hot-swap SED HDDs - 12 Gb SAS 10K			
7XB7A00030	AUM4	ThinkSystem 2.5" 300GB 10K SAS 12Gb Hot Swap 512n HDD SED	4
7XB7A00031	AUM5	ThinkSystem 2.5" 600GB 10K SAS 12Gb Hot Swap 512n HDD SED	4
7XB7A00033	B0YX	ThinkSystem 2.5" 1.2TB 10K SAS 12Gb Hot Swap 512n HDD SED	4

Table 10. 2.5-inch hot-swap 6 Gb SATA HDDs

Part number	Feature	Description	Maximum supported
2.5-inch hot-swap HDDs - 6 Gb NL SATA			
7XB7A00036	AUUE	ThinkSystem 2.5" 1TB 7.2K SATA 6Gb Hot Swap 512n HDD	4
7XB7A00037	AUUJ	ThinkSystem 2.5" 2TB 7.2K SATA 6Gb Hot Swap 512e HDD	4

Table 11. 2.5-inch hot-swap 12 Gb SAS SSDs

Part number	Feature	Description	Maximum supported
2.5-inch hot-swap SSDs - 12 Gb SAS - Performance (10+ DWPD)			
4XB7A10219	B4Y4	ThinkSystem 2.5" SS530 400GB Performance SAS 12Gb Hot Swap SSD	4
4XB7A10230	B4Y5	ThinkSystem 2.5" SS530 800GB Performance SAS 12Gb Hot Swap SSD	4
4XB7A10231	B4Y6	ThinkSystem 2.5" SS530 1.6TB Performance SAS 12Gb Hot Swap SSD	4
4XB7A10232	B4Y7	ThinkSystem 2.5" SS530 3.2TB Performance SAS 12Gb Hot Swap SSD	4
7N47A00124	AUMG	ThinkSystem 2.5" HUSMM32 400GB Performance SAS 12Gb Hot Swap SSD	4
2.5-inch hot-swap SSDs - 12 Gb SAS - Mainstream (3-5 DWPD)			
4XB7A17062	B8HU	ThinkSystem 2.5" PM1645a 800GB Mainstream SAS 12Gb Hot Swap SSD	4
4XB7A17063	B8J4	ThinkSystem 2.5" PM1645a 1.6TB Mainstream SAS 12Gb Hot Swap SSD	4
4XB7A17064	B8JD	ThinkSystem 2.5" PM1645a 3.2TB Mainstream SAS 12Gb Hot Swap SSD	4
4XB7A17065	B8JA	ThinkSystem 2.5" PM1645a 6.4TB Mainstream SAS 12Gb Hot Swap SSD	4
4XB7A13653	B4A0	ThinkSystem 2.5" PM1645 800GB Mainstream SAS 12Gb Hot Swap SSD	4
4XB7A13654	B4A1	ThinkSystem 2.5" PM1645 1.6TB Mainstream SAS 12Gb Hot Swap SSD	4
4XB7A13655	B4A2	ThinkSystem 2.5" PM1645 3.2TB Mainstream SAS 12Gb Hot Swap SSD	4
7N47A00117	AUMC	ThinkSystem 2.5" PM1635a 400GB Mainstream SAS 12Gb Hot Swap SSD	4
7N47A00119	AVRG	ThinkSystem 2.5" PM1635a 1.6TB Mainstream SAS 12Gb Hot Swap SSD	4
7N47A00120	AVRJ	ThinkSystem 2.5" PM1635a 3.2TB Mainstream SAS 12Gb Hot Swap SSD	4
2.5-inch hot-swap SSDs - 12 Gb SAS - Entry / Capacity (<3 DWPD)			
4XB7A38175	B91A	ThinkSystem 2.5" PM1643a 960GB Entry SAS 12Gb Hot Swap SSD	4
4XB7A38176	B91B	ThinkSystem 2.5" PM1643a 1.92TB Entry SAS 12Gb Hot Swap SSD	4
4XB7A17054	B91C	ThinkSystem 2.5" PM1643a 3.84TB Entry SAS 12Gb Hot Swap SSD	4
4XB7A17055	B91D	ThinkSystem 2.5" PM1643a 7.68TB Entry SAS 12Gb Hot Swap SSD	4
4XB7A17056	BC4R	ThinkSystem 2.5" PM1643a 15.36TB Entry SAS 12Gb Hot Swap SSD	4
4XB7A13645	B4A7	ThinkSystem 2.5" PM1643 3.84TB Capacity SAS 12Gb Hot Swap SSD	4
4XB7A13646	B4A6	ThinkSystem 2.5" PM1643 7.68TB Capacity SAS 12Gb Hot Swap SSD	4
7N47A00123	B116	ThinkSystem 2.5" PM1633a 15.36TB Capacity SAS 12Gb Hot Swap SSD	4

Table 12. 2.5-inch hot-swap 6 Gb SATA SSDs

Part number	Feature	Description	Maximum supported
2.5-inch hot-swap SSDs - 6 Gb SATA - Mainstream (3-5 DWPD)			
4XB7A17087	B8J1	ThinkSystem 2.5" 5300 240GB Mainstream SATA 6Gb Hot Swap SSD	4
4XB7A17088	B8HY	ThinkSystem 2.5" 5300 480GB Mainstream SATA 6Gb Hot Swap SSD	4
4XB7A17089	B8J6	ThinkSystem 2.5" 5300 960GB Mainstream SATA 6Gb Hot Swap SSD	4
4XB7A17090	B8JE	ThinkSystem 2.5" 5300 1.92TB Mainstream SATA 6Gb Hot Swap SSD	4
4XB7A17091	B8J7	ThinkSystem 2.5" 5300 3.84TB Mainstream SATA 6Gb Hot Swap SSD	4
4XB7A13633	B49L	ThinkSystem 2.5" Intel S4610 240GB Mainstream SATA 6Gb Hot Swap SSD	4
4XB7A13634	B49M	ThinkSystem 2.5" Intel S4610 480GB Mainstream SATA 6Gb Hot Swap SSD	4
4XB7A13635	B49N	ThinkSystem 2.5" Intel S4610 960GB Mainstream SATA 6Gb Hot Swap SSD	4
4XB7A13636	B49P	ThinkSystem 2.5" Intel S4610 1.92TB Mainstream SATA 6Gb Hot Swap SSD	4
4XB7A13637	B49Q	ThinkSystem 2.5" Intel S4610 3.84TB Mainstream SATA 6Gb Hot Swap SSD	4

Part number	Feature	Description	Maximum supported
4XB7A10237	B488	ThinkSystem 2.5" 5200 240GB Mainstream SATA 6Gb Hot Swap SSD	4
4XB7A10238	B489	ThinkSystem 2.5" 5200 480GB Mainstream SATA 6Gb Hot Swap SSD	4
4XB7A10239	B48A	ThinkSystem 2.5" 5200 960GB Mainstream SATA 6Gb Hot Swap SSD	4
4XB7A10240	B48B	ThinkSystem 2.5" 5200 1.92TB Mainstream SATA 6Gb Hot Swap SSD	4
4XB7A10241	B48C	ThinkSystem 2.5" 5200 3.84TB Mainstream SATA 6Gb Hot Swap SSD	4
7SD7A05723	B0ZP	ThinkSystem 2.5" Intel S4600 240GB Mainstream SATA 6Gb Hot Swap SSD	4
7SD7A05722	B0ZQ	ThinkSystem 2.5" Intel S4600 480GB Mainstream SATA 6Gb Hot Swap SSD	4
7SD7A05721	B0ZR	ThinkSystem 2.5" Intel S4600 960GB Mainstream SATA 6Gb Hot Swap SSD	4
7SD7A05720	B0ZS	ThinkSystem 2.5" Intel S4600 1.92TB Mainstream SATA 6Gb Hot Swap SSD	4
7SD7A05765	B10W	ThinkSystem 2.5" 5100 240GB Mainstream SATA 6Gb Hot Swap SSD	4
7SD7A05764	B10X	ThinkSystem 2.5" 5100 480GB Mainstream SATA 6Gb Hot Swap SSD	4
7SD7A05763	B10Y	ThinkSystem 2.5" 5100 960GB Mainstream SATA 6Gb Hot Swap SSD	4
7SD7A05762	B10Z	ThinkSystem 2.5" 5100 1.92TB Mainstream SATA 6Gb Hot Swap SSD	4
7SD7A05761	B110	ThinkSystem 2.5" 5100 3.84TB Mainstream SATA 6Gb Hot Swap SSD	4
2.5-inch hot-swap SSDs - 6 Gb SATA - Entry (<3 DWPD)			
4XB7A38271	BCTC	ThinkSystem 2.5" Multi Vendor 240GB Entry SATA 6Gb Hot Swap SSD	4
4XB7A38272	BCTD	ThinkSystem 2.5" Multi Vendor 480GB Entry SATA 6Gb Hot Swap SSD	4
4XB7A38273	BCTE	ThinkSystem 2.5" Multi Vendor 960GB Entry SATA 6Gb Hot Swap SSD	4
4XB7A38274	BCTF	ThinkSystem 2.5" Multi Vendor 1.92TB Entry SATA 6Gb Hot Swap SSD	4
4XB7A38275	BCTG	ThinkSystem 2.5" Multi Vendor 3.84TB Entry SATA 6Gb Hot Swap SSD	4
4XB7A17075	B8HV	ThinkSystem 2.5" 5300 240GB Entry SATA 6Gb Hot Swap SSD	4
4XB7A17076	B8JM	ThinkSystem 2.5" 5300 480GB Entry SATA 6Gb Hot Swap SSD	4
4XB7A17077	B8HP	ThinkSystem 2.5" 5300 960GB Entry SATA 6Gb Hot Swap SSD	4
4XB7A17078	B8J5	ThinkSystem 2.5" 5300 1.92TB Entry SATA 6Gb Hot Swap SSD	4
4XB7A17079	B8JP	ThinkSystem 2.5" 5300 3.84TB Entry SATA 6Gb Hot Swap SSD	4
4XB7A17080	B8J2	ThinkSystem 2.5" 5300 7.68TB Entry SATA 6Gb Hot Swap SSD	4
4XB7A38185	B9AC	ThinkSystem 2.5" 5210 960GB Entry SATA 6Gb Hot Swap QLC SSD	4
4XB7A38144	B7EW	ThinkSystem 2.5" 5210 1.92TB Entry SATA 6Gb Hot Swap QLC SSD	4
4XB7A38145	B7EX	ThinkSystem 2.5" 5210 3.84TB Entry SATA 6Gb Hot Swap QLC SSD	4
4XB7A38146	B7EY	ThinkSystem 2.5" 5210 7.68TB Entry SATA 6Gb Hot Swap QLC SSD	4
4XB7A10247	B498	ThinkSystem 2.5" Intel S4510 240GB Entry SATA 6Gb Hot Swap SSD	4
4XB7A10248	B499	ThinkSystem 2.5" Intel S4510 480GB Entry SATA 6Gb Hot Swap SSD	4
4XB7A10249	B49A	ThinkSystem 2.5" Intel S4510 960GB Entry SATA 6Gb Hot Swap SSD	4
4XB7A13622	B49B	ThinkSystem 2.5" Intel S4510 1.92TB Entry SATA 6Gb Hot Swap SSD	4
4XB7A13623	B49C	ThinkSystem 2.5" Intel S4510 3.84TB Entry SATA 6Gb Hot Swap SSD	4
4XB7A10195	B34H	ThinkSystem 2.5" PM883 240GB Entry SATA 6Gb Hot Swap SSD	4
4XB7A10196	B34J	ThinkSystem 2.5" PM883 480GB Entry SATA 6Gb Hot Swap SSD	4
4XB7A10197	B34K	ThinkSystem 2.5" PM883 960GB Entry SATA 6Gb Hot Swap SSD	4
4XB7A10198	B34L	ThinkSystem 2.5" PM883 1.92TB Entry SATA 6Gb Hot Swap SSD	4
4XB7A10199	B34M	ThinkSystem 2.5" PM883 3.84TB Entry SATA 6Gb Hot Swap SSD	4
4XB7A10200	B4D2	ThinkSystem 2.5" PM883 7.68TB Entry SATA 6Gb Hot Swap SSD	4
7SD7A05742	B0YY	ThinkSystem 2.5" Intel S4500 240GB Entry SATA 6Gb Hot Swap SSD	4
7SD7A05741	B0YZ	ThinkSystem 2.5" Intel S4500 480GB Entry SATA 6Gb Hot Swap SSD	4

Part number	Feature	Description	Maximum supported
7SD7A05740	B0Z0	ThinkSystem 2.5" Intel S4500 960GB Entry SATA 6Gb Hot Swap SSD	4
7SD7A05739	B0Z1	ThinkSystem 2.5" Intel S4500 1.92TB Entry SATA 6Gb Hot Swap SSD	4
7SD7A05738	B0Z2	ThinkSystem 2.5" Intel S4500 3.84TB Entry SATA 6Gb Hot Swap SSD	4
7N47A00111	AUUQ	ThinkSystem 2.5" PM863a 240GB Entry SATA 6Gb Hot Swap SSD	4
7N47A00112	AUM9	ThinkSystem 2.5" PM863a 480GB Entry SATA 6Gb Hot Swap SSD	4
7N47A00113	AVCZ	ThinkSystem 2.5" PM863a 960GB Entry SATA 6Gb Hot Swap SSD	4
7N47A00114	AVRC	ThinkSystem 2.5" PM863a 1.92TB Entry SATA 6Gb Hot Swap SSD	4
4XB7A10153	B2X2	ThinkSystem 2.5" 5200 480GB Entry SATA 6Gb Hot Swap SSD	4
4XB7A10154	B2X3	ThinkSystem 2.5" 5200 960GB Entry SATA 6Gb Hot Swap SSD	4
4XB7A10155	B2X4	ThinkSystem 2.5" 5200 1.92TB Entry SATA 6Gb Hot Swap SSD	4
4XB7A10156	B2X5	ThinkSystem 2.5" 5200 3.84TB Entry SATA 6Gb Hot Swap SSD	4
4XB7A10157	B2X6	ThinkSystem 2.5" 5200 7.68TB Entry SATA 6Gb Hot Swap SSD	4
4XB7A08502	B10N	ThinkSystem 2.5" 5100 480GB Entry SATA 6Gb Hot Swap SSD	4
4XB7A08503	B10P	ThinkSystem 2.5" 5100 960GB Entry SATA 6Gb Hot Swap SSD	4
4XB7A08504	B10Q	ThinkSystem 2.5" 5100 1.92TB Entry SATA 6Gb Hot Swap SSD	4
4XB7A08505	B10R	ThinkSystem 2.5" 5100 3.84TB Entry SATA 6Gb Hot Swap SSD	4
7N47A00099	AUM8	ThinkSystem 2.5" Intel S3520 240GB Entry SATA 6Gb Hot Swap SSD	4
7N47A00100	AUUZ	ThinkSystem 2.5" Intel S3520 480GB Entry SATA 6Gb Hot Swap SSD	4
7N47A00101	AVCY	ThinkSystem 2.5" Intel S3520 960GB Entry SATA 6Gb Hot Swap SSD	4

Table 13. 2.5-inch hot-swap PCIe 4.0 NVMe SSDs (operate at PCIe 3.0 speeds in this server)

Part number	Feature	Description	Maximum supported
2.5-inch SSDs - PCIe 4.0 NVMe - Mainstream (3-5 DWPD)			
4XB7A17152	BCFV	ThinkSystem U.2 Intel P5600 1.6TB Mainstream NVMe PCIe 4.0 x4 Hot Swap SSD	4
4XB7A17153	BCFR	ThinkSystem U.2 Intel P5600 3.2TB Mainstream NVMe PCIe 4.0 x4 Hot Swap SSD	4
4XB7A17154	BCFS	ThinkSystem U.2 Intel P5600 6.4TB Mainstream NVMe PCIe 4.0 x4 Hot Swap SSD	4
4XB7A64175	BE03	ThinkSystem U.3 Kioxia CM6-V 800GB Mainstream NVMe PCIe 4.0 x4 Hot Swap SSD	4
4XB7A17112	B96Z	ThinkSystem U.3 Kioxia CM6-V 1.6TB Mainstream NVMe PCIe4.0 x4 Hot Swap SSD	4
4XB7A17113	B96T	ThinkSystem U.3 Kioxia CM6-V 3.2TB Mainstream NVMe PCIe4.0 x4 Hot Swap SSD	4
4XB7A17114	B96P	ThinkSystem U.3 Kioxia CM6-V 6.4TB Mainstream NVMe PCIe4.0 x4 Hot Swap SSD	4
2.5-inch SSDs - PCIe 4.0 NVMe - Entry (<3 DWPD)			
4XB7A17145	BCFT	ThinkSystem U.2 Intel P5500 1.92TB Entry NVMe PCIe 4.0 x4 Hot Swap SSD	4
4XB7A17146	BCFW	ThinkSystem U.2 Intel P5500 3.84TB Entry NVMe PCIe 4.0 x4 Hot Swap SSD	4
4XB7A17147	BCFU	ThinkSystem U.2 Intel P5500 7.68TB Entry NVMe PCIe 4.0 x4 Hot Swap SSD	4

Table 14. 2.5-inch hot-swap PCIe 3.0 NVMe SSDs

Part number	Feature	Description	Maximum supported
2.5-inch SSDs - PCIe 3.0 NVMe - Performance (10+ DWPD)			
7N47A00081	AUMJ	ThinkSystem U.2 Intel Optane P4800X 375GB Performance NVMe PCIe 3.0 x4 Hot Swap SSD	4
7XB7A05923	AWG6	ThinkSystem U.2 PX04PMB 800GB Performance NVMe PCIe 3.0 x4 Hot Swap SSD	4
7XB7A05922	AWG7	ThinkSystem U.2 PX04PMB 1.6TB Performance NVMe PCIe 3.0 x4 Hot Swap SSD	4
2.5-inch SSDs - PCIe 3.0 NVMe - Mainstream (3-5 DWPD)			
4XB7A13936	B589	ThinkSystem U.2 Intel P4610 1.6TB Mainstream NVMe PCIe3.0 x4 Hot Swap SSD	4
4XB7A13937	B58A	ThinkSystem U.2 Intel P4610 3.2TB Mainstream NVMe PCIe3.0 x4 Hot Swap SSD	4
4XB7A13938	B58B	ThinkSystem U.2 Intel P4610 6.4TB Mainstream NVMe PCIe3.0 x4 Hot Swap SSD	4
4XB7A08516	B21W	ThinkSystem U.2 Toshiba CM5-V 800GB Mainstream NVMe PCIe 3.0 x4 Hot Swap SSD	4
4XB7A08517	B21X	ThinkSystem U.2 Toshiba CM5-V 1.6TB Mainstream NVMe PCIe 3.0 x4 Hot Swap SSD	4
4XB7A08518	B21Y	ThinkSystem U.2 Toshiba CM5-V 3.2TB Mainstream NVMe PCIe 3.0 x4 Hot Swap SSD	4
4XB7A08519	B2XJ	ThinkSystem U.2 Toshiba CM5-V 6.4TB Mainstream NVMe PCIe 3.0 x4 Hot Swap SSD	4
7N47A00095	AUUY	ThinkSystem U.2 PX04PMB 960GB Mainstream NVMe PCIe 3.0 x4 Hot Swap SSD	4
7N47A00096	AUMF	ThinkSystem U.2 PX04PMB 1.92TB Mainstream NVMe PCIe 3.0 x4 Hot Swap SSD	4
7SD7A05772	B11J	ThinkSystem U.2 Intel P4600 1.6TB Mainstream NVMe PCIe3.0 x4 Hot Swap SSD	4
7SD7A05771	B11K	ThinkSystem U.2 Intel P4600 3.2TB Mainstream NVMe PCIe3.0 x4 Hot Swap SSD	4
2.5-inch SSDs - PCIe 3.0 NVMe - Entry (<3 DWPD)			
4XB7A10202	B58F	ThinkSystem U.2 Intel P4510 1.0TB Entry NVMe PCIe3.0 x4 Hot Swap SSD	4
4XB7A10204	B58G	ThinkSystem U.2 Intel P4510 2.0TB Entry NVMe PCIe3.0 x4 Hot Swap SSD	4
4XB7A10205	B58H	ThinkSystem U.2 Intel P4510 4.0TB Entry NVMe PCIe3.0 x4 Hot Swap SSD	4
4XB7A10175	B34N	ThinkSystem U.2 PM983 1.92TB Entry NVMe PCIe 3.0 x4 Hot Swap SSD	4
4XB7A10176	B34P	ThinkSystem U.2 PM983 3.84TB Entry NVMe PCIe 3.0 x4 Hot Swap SSD	4
4XB7A10177	B4D3	ThinkSystem U.2 PM983 7.68TB Entry NVMe PCIe3.0 x4 Hot Swap SSD	4
7N47A00984	AUV0	ThinkSystem U.2 PM963 1.92TB Entry NVMe PCIe 3.0 x4 Hot Swap SSD	4
7N47A00985	AUUU	ThinkSystem U.2 PM963 3.84TB Entry NVMe PCIe 3.0 x4 Hot Swap SSD	4
7SD7A05779	B11C	ThinkSystem U.2 Intel P4500 1.0TB Entry NVMe PCIe3.0 x4 Hot Swap SSD	4
7SD7A05778	B11D	ThinkSystem U.2 Intel P4500 2.0TB Entry NVMe PCIe3.0 x4 Hot Swap SSD	4
7SD7A05777	B11E	ThinkSystem U.2 Intel P4500 4.0TB Entry NVMe PCIe3.0 x4 Hot Swap SSD	4

Note: NVMe PCIe SSDs support surprise hot removal and hot insertion, provided the operating system supports PCIe SSD hot-swap.

Table 15. M.2 SATA drives

Part number	Feature	Description	Maximum supported
M.2 SSDs - 6 Gb SATA - Entry (<3 DWPD)			
7N47A00129	AUUL	ThinkSystem M.2 32GB SATA 6Gbps Non-Hot Swap SSD	2
7N47A00130	AUUV	ThinkSystem M.2 128GB SATA 6Gbps Non-Hot Swap SSD	2
4XB7A14049	B5S4	ThinkSystem M.2 5100 240GB SATA 6Gbps Non-Hot Swap SSD	2
7SD7A05703	B11V	ThinkSystem M.2 5100 480GB SATA 6Gbps Non-Hot Swap SSD	2
4XB7A17071	B8HS	ThinkSystem M.2 5300 240GB SATA 6Gbps Non-Hot Swap SSD	2
4XB7A17073	B919	ThinkSystem M.2 5300 480GB SATA 6Gbps Non-Hot Swap SSD	2

Integrated virtualization

The server supports booting from an operating system or hypervisor installed on an M.2 solid-state drive. See the [Internal storage](#) section for details and the list of available options. Preloaded M.2 drives can be configured as described in the [Operating system support](#) section.

You can download supported VMware vSphere hypervisor images from the following web page and load it on the M.2 drive using the instructions provided:

https://vmware.lenovo.com/content/custom_iso/

Internal tape drives

The server does not support an internal tape drive. However, it can be attached to external tape drives by using Fibre Channel connectivity.

Optical drives

The server does not support an internal optical drive, however, you can connect an external USB optical drive. Alternatively, use the remote media feature of the XClarity Controller and the Chassis Management Module.

The server supports the external USB optical drive listed in the following table.

Table 16. External optical drive

Part number	Feature code	Description
7XA7A05926	AVV8	ThinkSystem External USB DVD RW Optical Disk Drive

The drive is based on the Lenovo Slim DVD Burner DB65 drive and supports the following formats: DVD-RAM, DVD-RW, DVD+RW, DVD+R, DVD-R, DVD-ROM, DVD-R DL, CD-RW, CD-R, CD-ROM.

Embedded 10Gb Network Adapter

The SN850 includes an embedded 4-port 10Gb Intel controller built into the system board. As listed in the [Models](#) section, some SN850 models include the Fabric Connector needed to connect the embedded controller to the midplane of the Flex System chassis. For models that do not include the Fabric Connector, it can be ordered and installed in the field. Ordering information is listed in the following table.

Table 17. Fabric Connector ordering information

Part number	Feature code	Description
7M27A03927	AUYN	Lenovo ThinkSystem Server Fabric Connector

The location of the fabric connector is shown below.

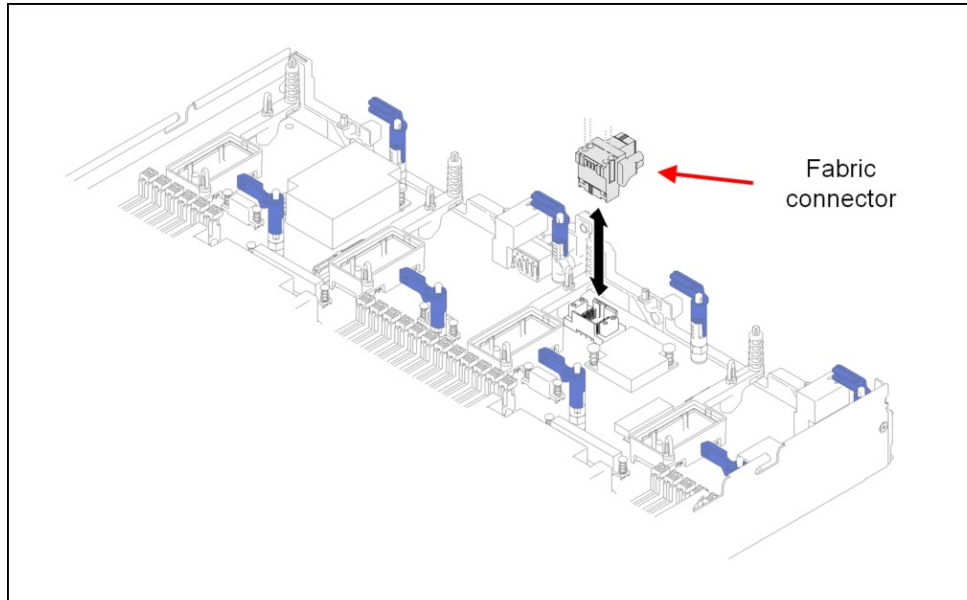

Figure 6. Location of fabric connector in SN850 server

Table 25 and Figure 9 show how the 4 ports of the embedded controller connect through the Fabric Connector to the corresponding I/O module ports. The Fabric Connector can be removed, if required, to allow the installation of an I/O adapter on I/O connector 3.

The embedded 10Gb controller is based on the Intel Ethernet Connection X722 network controller which is part of the Intel C624 "Lewisburg" PCH chipset of the SN850 and other Lenovo ThinkSystem servers.

The Intel X722 controller is optimized for data center, cloud, and mobile applications and includes the following features:

- **VXLAN/NVGRE Hardware Offloads:** These stateless offloads preserve application performance for overlay networks. With these offloads, it is possible to distribute network traffic across CPU cores. At the same time, the controller offloads LSO, GSO, and checksum from the host software, which reduces CPU overhead.
- **Low latency:** Intel Ethernet Flow Director delivers hardware-based application steering and Intel Data Direct I/O makes the processor cache the primary destination and source of I/O data rather than main memory.
- **Virtualization performance:** With Intel Virtualization Technology (VT), the controller delivers outstanding I/O performance in virtualized server environments. The controller reduces I/O bottlenecks by providing intelligent offloads for networking traffic per virtual machine (VM), which enables near-line rate speeds for small packets and supports almost an unlimited amount of isolated traffic flows so that you can scale your cloud environment.
- **Next-generation VMDq:** The controller supports up to 128 VMDq VMs and offers enhanced Quality of Service (QoS) by providing weighted round-robin servicing for the Tx data. The controller offloads the data-sorting functionality from the hypervisor to the network silicon, which improves data throughput and CPU usage.
- **SR-IOV implementation:** Provides an implementation of the PCI-SIG standard for I/O Virtualization. The physical configuration of each port is divided into multiple virtual ports. Each virtual port is assigned to an individual VM directly by bypassing the virtual switch in the Hypervisor, which results in near-native performance.
- **iWarp RDMA support** implements kernel bypass and direct data placement and allows for more efficient high-speed networking by eliminating queues and network related interrupts
- **VM load balancing:** Provides traffic load balancing (Tx and Rx) across VMs that are bound to the team interface. It also provides fault tolerance if a switch, port, or cable fails or is disconnected.
- **Auto-detect (PnP) feature** for the LOM adapters, enabling you to change speed (eg from a 1Gb LOM to 10 Gb LOM) and the network interface will automatically reconfigure during the boot process.

Note: The onboard Ethernet controller does not support 10 Mb or 100 Mb Ethernet connections.

I/O expansion options

The SN850 has four I/O expansion connectors for attaching I/O adapter cards. The I/O expansion connectors use a high-density, 216-pin PCIe connection. Installing I/O adapter cards allows the server to connect with I/O modules in the chassis. Each slot has a PCI Express 3.0 x16 host interface and all slots support the same form-factor adapters.

The following figure shows the location of the I/O expansion connectors.

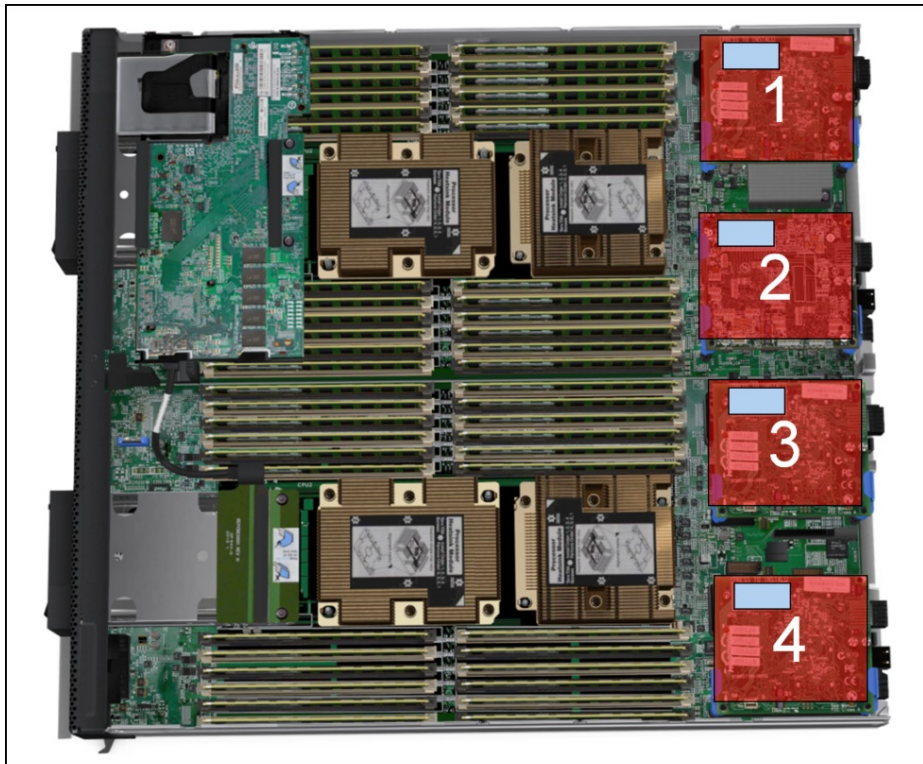

Figure 7. Location of the I/O adapter slots in the SN850 server

All I/O adapters are the same form factor. A compatible switch or pass-through module must be installed in the corresponding I/O bays in the chassis, as indicated in the following table. Installing two switches means that all ports of the adapter are enabled, which improves performance and network availability.

Table 18. Adapter to I/O bay correspondence

I/O adapter slot in the server	Port on the adapter	Corresponding I/O module bay in the chassis
Slot 1	Port 1	Module bay 1
	Port 2	Module bay 2
	Port 3 (for 4-port cards)	Module bay 1
	Port 4 (for 4-port cards)	Module bay 2
Slot 2	Port 1	Module bay 3
	Port 2	Module bay 4
	Port 3 (for 4-port cards)	Module bay 3
	Port 4 (for 4-port cards)	Module bay 4
Slot 3	Port 1	Module bay 1
	Port 2	Module bay 2
	Port 3 (for 4-port cards)	Module bay 1
	Port 4 (for 4-port cards)	Module bay 2
Slot 4	Port 1	Module bay 3
	Port 2	Module bay 4
	Port 3 (for 4-port cards)	Module bay 3
	Port 4 (for 4-port cards)	Module bay 4

For more information about supported switches, see the Flex System Interoperability Guide, which is available at this web page:

<http://lenovopress.com/fsig>

The following figure shows the location of the I/O module bays in the Flex System Enterprise Chassis.

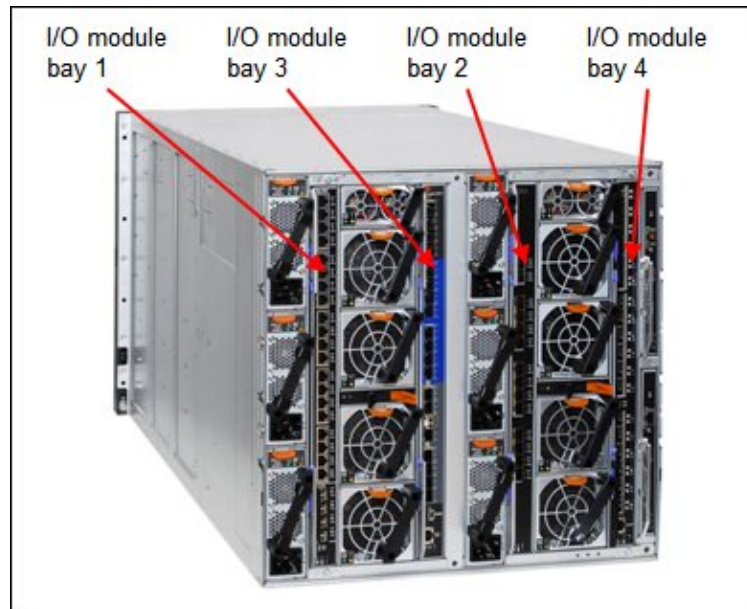

Figure 8. Location of the I/O module bays in the Flex System Enterprise Chassis

The following figure shows how two-port adapters are connected to switches that are installed in the chassis.

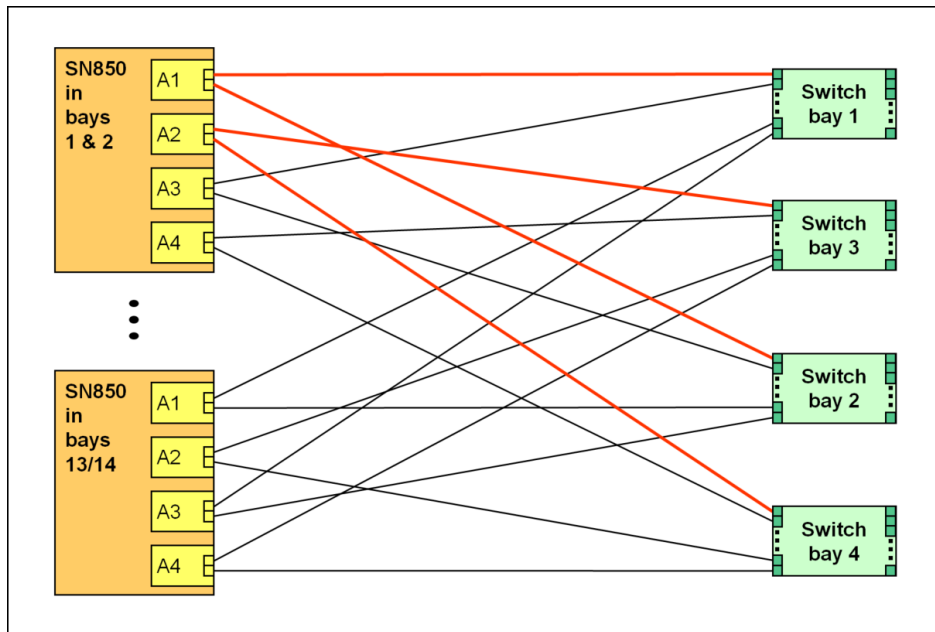

Figure 9. Logical layout of the interconnects between I/O adapters and I/O modules

Network adapters

In addition to the embedded Intel 4-port 10Gb controller (model specific), the SN850 supports other network adapters that can be installed in IO slots.

The following table lists the supported network adapters and upgrades. Adapters can be installed in any slot. However, compatible switches must be installed in the corresponding bays of the chassis.

Table 19. Network adapters

Part number	Feature code	Description	Number of ports
50 Gb Ethernet			
7XC7A05843	B2VT	ThinkSystem QLogic QL45212 Flex 50Gb 2-Port Ethernet Adapter	2
7XC7A05845	B2VV	ThinkSystem QLogic QL45262 Flex 50Gb 2-Port Ethernet Adapter with iSCSI/FCoE	2
40 Gb Ethernet			
7ZT7A00502	AVCU	ThinkSystem Mellanox ConnectX-3 Mezz 40Gb 2-Port Ethernet Adapter	2
25 Gb Ethernet			
7XC7A05844	B2VU	ThinkSystem QLogic QL45214 Flex 25Gb 4-Port Ethernet Adapter	4
10 Gb Ethernet			
01CV780	AU7X	Flex System CN4052S 2-port 10Gb Virtual Fabric Adapter Advanced (with FCoE / iSCSI)	2
00AG540	ATBT	Flex System CN4052S 2-port 10Gb Virtual Fabric Adapter	2
01CV790	AU7Y	Flex System CN4054S 4-port 10Gb Virtual Fabric Adapter Advanced (with FCoE / iSCSI)	4
00AG590	ATBS	Flex System CN4054S 4-port 10Gb Virtual Fabric Adapter	4
InfiniBand			
7ZT7A00508	AUKV	ThinkSystem Mellanox ConnectX-3 Mezz FDR 2-Port InfiniBand Adapter	2

FCoE and iSCSI support: ThinkSystem server adapters do not support Features on Demand, so the CN4052S and CN4054S 2-port 10Gb basic adapters cannot be upgraded to FCoE support. If you need FCoE or iSCSI support use the 01CV780 or 01CV790 adapters.

For more details about these adapters, see the Lenovo Press product guides in the Network adapters category: <https://lenovopress.com/servers/blades/nic>

For more information about adapter-to-switch compatibility, see the Flex System Interoperability Guide: <http://lenovopress.com/fsig>

Storage host bus adapters

The following table lists storage Host Bus Adapters (HBAs) that are supported by the SN850. Storage HBAs are supported in all slots, however for CTO orders, the HBAs are installed only in slots 2 and 4.

Table 20. Storage adapters

Part number	Feature code	Description	Number of ports
Fibre Channel			
7ZT7A00520	AVCV	ThinkSystem QLogic QML2692 Mezz 16Gb 2-Port Fibre Channel Adapter	2
7ZT7A00521	AVCW	ThinkSystem Emulex LPm16002B-L Mezz 16Gb 2-Port Fibre Channel Adapter	2
7ZT7A00522	AVCX	ThinkSystem Emulex LPm16004B-L Mezz 16Gb 4-Port Fibre Channel Adapter	4

For details about these adapters, see the Lenovo Press product guides in the Storage adapters category: <https://lenovopress.com/servers/blades/hba>

For more information about adapter-to-switch compatibility, see the Flex System Interoperability Guide: <http://lenovopress.com/fsig>

Power supplies

Power to the blade server is derived from the power supplies that are installed in the chassis. There are no server options regarding power supplies.

System Management

The server contains an integrated service processor, XClarity Controller (XCC), which provides advanced service-processor control, monitoring, and alerting functions. The XCC is based on the Pilot4 XE401 baseboard management controller (BMC) using a dual-core ARM Cortex A9 service processor.

Local management

As shown in [Figure 2](#), the SN850 front panel includes a USB port, status indicators, a button to enable management via the USB port and a console breakout cable port. The breakout cable (supplied with the chassis) provides serial, video and a USB port for connecting a local console. The USB ports on the breakout cable support keyboard and mouse; storage devices are not supported.

System status with XClarity Mobile

The Lenovo XClarity Mobile (LXCM) app now includes a tethering function where you can connect your Android or iOS device to the server via USB to see the status of the server.

The steps to connect the mobile device are as follows:

1. Enable USB Management on the server, by pressing and holding for 3 seconds the dedicated USB management button on the front of the server.
2. Connect the mobile device via a USB cable to the server's USB port with the management symbol
3. In iOS or Android settings, enable Personal Hotspot or USB Tethering
4. Launch the Lenovo XClarity Mobile app

Once connected you can see the following information:

- Server status including error logs (read only, no login required)
- Server management functions (XClarity login credentials required)

Light Path Diagnostics

The SN850 includes light path diagnostics. If an environmental condition exceeds a threshold or if a system component fails, XCC lights LEDs inside the server to help you diagnose the problem and find the failing part.

For quick problem determination when you are physically at the server, the server offers the following three-step guided path:

- Illuminate the Fault LED on the front panel.
- Identify the fault in the light path diagnostics panel, as shown in the following figure.
- If a DIMM is faulty, the LED next to it is illuminated.

The SN850 light path diagnostics panel is inside the server near the front panel, as shown in the following figure.

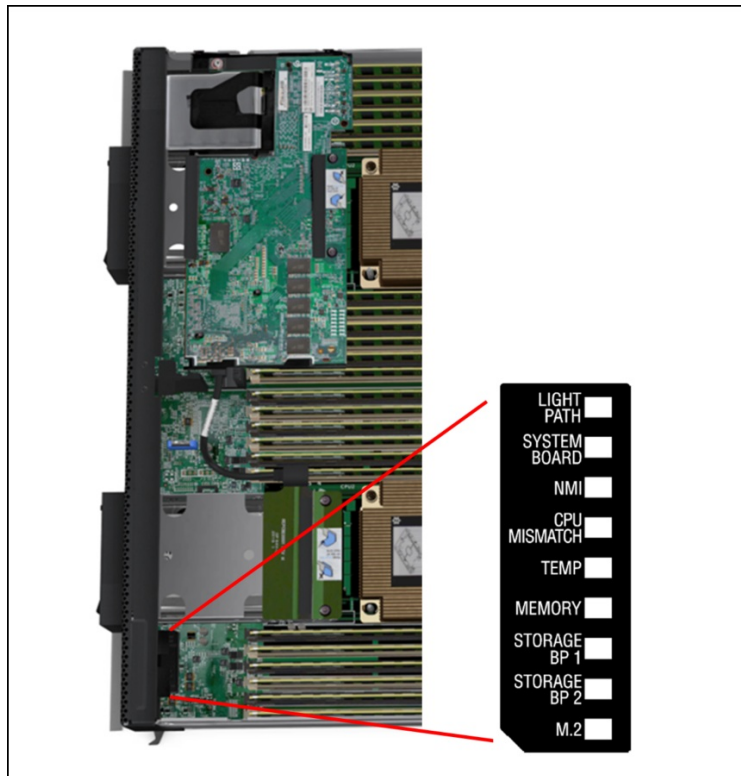

Figure 10. Location of SN850 light path diagnostics panel

To illuminate the light path diagnostics LEDs, power off the server, slide it out of the chassis, and press and hold the power button. The power button doubles as the light path diagnostics reminder button when the server is removed from the chassis.

The meanings of the LEDs in the light path diagnostics panel are listed in the following table.

Table 21. Light path diagnostic panel LEDs

LED	Meaning
LIGHT PATH	The light path diagnostics panel is operational.
SYSTEM BOARD	A system board error is detected.
NMI	A non-maskable interrupt (NMI) occurred.
CPU MISMATCH	The processors are mismatched.
TEMP	An over-temperature condition occurred that was critical enough to shut down the server.
MEMORY	A memory fault occurred. The corresponding DIMM error LEDs on the system board are also lit.
STORAGE BP 1	A hard disk drive backplane error has occurred.
M.2	A M.2 backplane error has occurred.

The front of the server also houses an information pull-out tab. See [Figure 2](#) for the location. A label on the tab shows the network information (MAC address and other data) to remotely access XClarity Controller.

Remote management

Lenovo XClarity Controller (XCC) is an embedded management engine common in every ThinkSystem server.

There are two ways to access the management processor:

- Command-line interface. To access the CLI interface, use SSH to log in to the management processor.
- Web-based interface. To access the web-based interface, point your browser to the IP address for the management processor. The intuitive interface includes at-a-glance visualizations and simple access to common system actions. The dashboard is shown in the following figure.

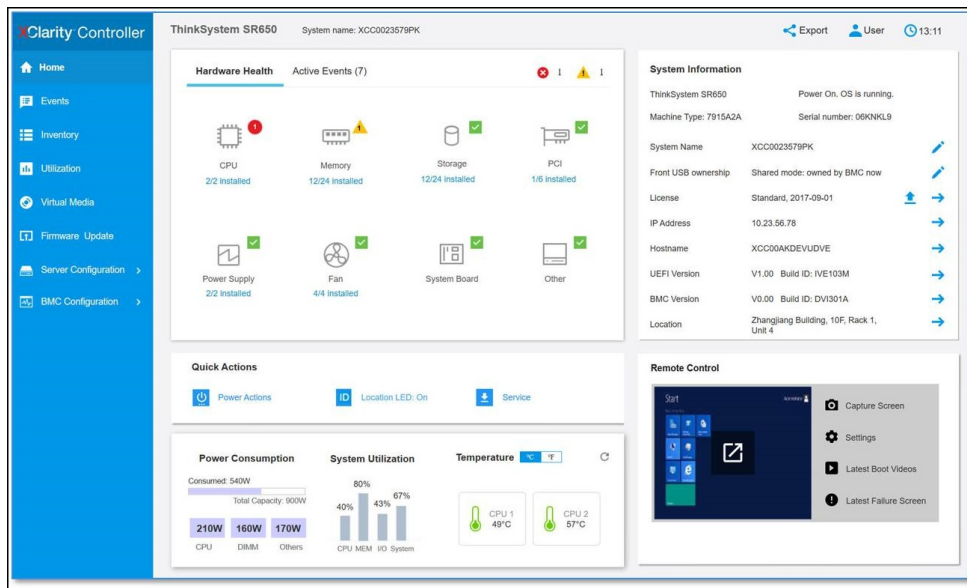

Figure 11. Lenovo XClarity Controller dashboard

Remote server management is provided through industry-standard interfaces:

- Intelligent Platform Management Interface (IPMI) Version 2.0
- Simple Network Management Protocol (SNMP) Version 3 (no SET commands; no SMNP v1)
- Common Information Model (CIM-XML)
- Representational State Transfer (REST) support
- Redfish support (DMTF compliant)
- Web browser - HTML 5-based browser interface (Java and ActiveX not required) using a responsive design (content optimized for device being used - laptop, tablet, phone) with NLS support

IPMI via the Ethernet port (IPMI over LAN) is supported, however it is disabled by default. For CTO orders you can specify whether you want the feature enabled or disabled in the factory, using the feature codes listed in the following table.

Table 22. IPMI-over-LAN settings

Part number	Feature code	Description
CTO only	B7XZ	Disable IPMI-over-LAN (default)
CTO only	B7Y0	Enable IPMI-over-LAN

Virtual presence (remote control) and virtual media capability also come standard in the SN850. The remote control functions include the following:

- Remotely viewing video with graphics resolutions up to 1600x1200 at 75 Hz with up to 32 bits per pixel, regardless of the system state
- Remotely accessing the server using the keyboard and mouse from a remote client
- Capturing blue-screen errors
- International keyboard mapping support
- LDAP-based authentication
- Remote mounting of ISO and diskette IMG image files as virtual drives that are available for use by the server
- Boot Capture
- Virtual console collaboration - Ability for up to 6 remote users to be log into the remote session simultaneously
- Power capping

Lenovo XClarity Energy Manager

Lenovo XClarity Energy Manager (LXEM) is an agent-less, web-based console that provides power management for ThinkServer, System x and ThinkSystem servers. It enables server density and data center capacity to be increased through the use of power capping.

LXEM is a licensed product. A single-node LXEM license is included with the XClarity Controller Enterprise (XCC Enterprise) version. Because the Enterprise version of XCC is standard in the SN850, a license for XClarity Energy Manager is included. For more information on LXEM, please see the User Guide: <http://datacentersupport.lenovo.com/us/en/downloads/ds101160>

Lenovo XClarity Administrator

Lenovo XClarity Administrator is a centralized resource management solution designed to reduce complexity, speed response, and enhance the availability of Lenovo systems and solutions. It provides agent-free hardware management for ThinkSystem servers. The administration dashboard is based on HTML 5 and allows fast location of resources so tasks can be run quickly.

Because Lenovo XClarity Administrator does not require any agent software to be installed on the managed endpoints, there are no CPU cycles spent on agent execution, and no memory is used, which means that up to 1GB of RAM and 1 - 2% CPU usage is saved, compared to a typical managed system where an agent is required.

Lenovo XClarity Administrator is an optional software component for the SN850. The software can be downloaded and used at no charge to discover and monitor the SN850 and to manage firmware upgrades.

If software support is required for Lenovo XClarity Administrator, or premium features such as configuration management and operating system deployment are required, Lenovo XClarity Pro software subscription should be ordered. Lenovo XClarity Pro is licensed on a per managed system basis, that is, each managed Lenovo system requires a license.

The following table lists the Lenovo XClarity software license options.

Table 23. Lenovo XClarity Pro ordering information

Part number	Feature code	Description
00MT201	1339	Lenovo XClarity Pro, per Managed Endpoint w/1 Yr SW S&S
00MT202	1340	Lenovo XClarity Pro, per Managed Endpoint w/3 Yr SW S&S
00MT203	1341	Lenovo XClarity Pro, per Managed Endpoint w/5 Yr SW S&S
7S0X000HWW	SAYV	Lenovo XClarity Pro, per Managed Endpoint w/6 Yr SW S&S
7S0X000JWW	SAYW	Lenovo XClarity Pro, per Managed Endpoint w/7 Yr SW S&S

Lenovo XClarity Administrator offers the following standard features that are available at no charge:

- Auto-discovery and monitoring of Lenovo systems
- Firmware updates and compliance enforcement
- External alerts and notifications via SNMP traps, syslog remote logging, and e-mail
- Secure connections to managed endpoints
- NIST 800-131A or FIPS 140-3 compliant cryptographic standards between the management solution and managed endpoints
- Integration into existing higher-level management systems such as cloud automation and orchestration tools through REST APIs, providing extensive external visibility and control over hardware resources
- An intuitive, easy-to-use GUI
- Scripting with Windows PowerShell, providing command-line visibility and control over hardware resources

Lenovo XClarity Administrator offers the following premium features that require an optional Pro license:

- Pattern-based configuration management that allows to define configurations once and apply repeatedly without errors when deploying new servers or redeploying existing servers without disrupting the fabric
- Bare-metal deployment of operating systems and hypervisors to streamline infrastructure provisioning

For more information, refer to the Lenovo XClarity Administrator Product Guide:

<http://lenovopress.com/tips1200>

Lenovo XClarity Integrators

Lenovo also offers software plug-in modules, Lenovo XClarity Integrators, to manage physical infrastructure from leading external virtualization management software tools including those from Microsoft and VMware.

These integrators are offered at no charge, however if software support is required, a Lenovo XClarity Pro software subscription license should be ordered.

Lenovo XClarity Integrators offer the following additional features:

- Ability to discover, manage, and monitor Lenovo server hardware from VMware vCenter or Microsoft System Center
- Deployment of firmware updates and configuration patterns to Lenovo x86 [rack servers](#) and Flex System from the virtualization management tool
- Non-disruptive server maintenance in clustered environments that reduces workload downtime by dynamically migrating workloads from affected hosts during rolling server updates or reboots
- Greater service level uptime and assurance in clustered environments during unplanned hardware events by dynamically triggering workload migration from impacted hosts when impending hardware failures are predicted

For more information about all the available Lenovo XClarity Integrators, see the Lenovo XClarity Administrator Product Guide: <https://lenovopress.com/tips1200-lenovo-xclarity-administrator>

Lenovo XClarity Provisioning Manager

Lenovo XClarity Provisioning Manager (LXPM) is a UEFI-based application embedded in ThinkSystem servers and accessible via the F1 key during system boot.

LXPM provides the following functions:

- Graphical UEFI Setup
- System inventory information and VPD update
- System firmware updates (UEFI and XCC)
- RAID setup wizard
- OS installation wizard (including unattended OS installation)
- Diagnostics functions

Lenovo XClarity Essentials

Lenovo offers the following XClarity Essentials software tools that can help you set up, use, and maintain the server at no additional cost:

- **Lenovo Essentials OneCLI**
OneCLI is a collection of server management tools that uses a command line interface program to manage firmware, hardware, and operating systems. It provides functions to collect full system health information (including health status), configure system settings, and update system firmware and drivers.
- **Lenovo Essentials UpdateXpress**
The UpdateXpress tool is a standalone GUI application for firmware and device driver updates that enables you to maintain your server firmware and device drivers up-to-date and help you avoid unnecessary server outages. The tool acquires and deploys individual updates and UpdateXpress System Packs (UXSPs) which are integration-tested bundles.
- **Lenovo Essentials Bootable Media Creator**
The Bootable Media Creator (BOMC) tool is used to create bootable media for offline firmware update.

For more information and downloads, visit the Lenovo XClarity Essentials web page:
<http://support.lenovo.com/us/en/documents/LNVO-center>

Security

The server offers the following security features:

- Administrator and power-on password
- Trusted Platform Module (TPM) supporting both TPM 1.2 and TPM 2.0
- Optional plugin Trusted Cryptographic Module (TCM) or Nationz TPM, available only in China
- Support for IBM Security Key Lifecycle Manager (SKLM) as described in the [Internal storage](#) section

The TCM and TPM plugin modules, available only for China customers, are installed in a dedicated socket on the system board, as shown in [Figure 3](#). Ordering information is shown in the following table.

Table 24. Security features

Part number	Feature code	Description
None*	AVKE	ThinkSystem Trusted Cryptographic Module (China customers only)
None*	B22N	ThinkSystem Nationz Trusted Platform Module v2.0 (China customers only)

* Available configure-to-order or pre-configured models only; Not available as a field upgrade.

Operating system support

The server supports the following operating systems:

For a complete list of supported, certified and tested operating systems, plus additional details and links to relevant web sites, see the Operating System Interoperability Guide: <https://lenovopress.com/osig#servers=sn850-7x15>

The server supports booting from a hypervisor installed on an M.2 solid-state drive. See the [Internal storage](#) section for details and the list of available options.

VMware ESXi is available as a factory installed option for M.2 drives. Feature codes are listed below.

Table 25. VMware factory installed features

Part number	Feature code	Description
CTO only	AXFS	VMware ESXi 6.0 U3 (factory installed)
CTO only	AXFT	VMware ESXi 6.5 U1 (factory installed)
CTO only	B3VW	VMware ESXi 6.5 U2 (Factory Installed)
CTO only	B6U0	VMware ESXi 6.5 U3 (factory installed)
CTO only	B3VX	VMware ESXi 6.7 (Factory Installed)
CTO only	B4XA	VMware ESXi 6.7 U1 (Factory Installed)
CTO only	B6U1	VMware ESXi 6.7 U2 (factory installed)
CTO only	B88T	VMware ESXi 6.7 U3 (factory installed)
CTO only	BBZG	VMware ESXi 7.0 (Factory Installed)
CTO only	BE5E	VMware ESXi 7.0 U1 (Factory Installed)

Alternatively, you can download supported VMware vSphere hypervisor images from the following web page and load it on the M.2 drives using the instructions provided: <https://www.lenovo.com/us/en/data-center/solutions/alliances/vmware/#tab-VMware-tab-main-2>

Physical specifications

The server features the following dimensions and weight (approximate):

- Width: 435 mm (17.1 in)
- Height: 56 mm (2.2 in)
- Depth: 493 mm (19.4 in)
- Maximum weight: 12.3 kg (27.0 lb)

The shipping (cardboard packaging) dimensions of the SN850 are as follows:

- Width: 685 mm (27.0 inches)
- Height: 195 mm (7.7 inches)
- Depth: 612 mm (24.1 inches)

Supported environment

The Lenovo ThinkSystem SN850 server complies with ASHRAE Class A3 specifications. System performance may be impacted when operating temperature is above ASHRAE A3 specification or fan failed condition.

- Air temperature:
 - Operating:
 - ASHRAE Class A2: 10 °C - 35 °C (50 °F - 95 °F); decrease the maximum ambient temperature by 1 °C for every 300 m (984 ft) increase in altitude above 900 m (2,953 ft)
 - ASHRAE Class A3: 5 °C - 40 °C (41 °F - 104 °F); decrease the maximum ambient temperature by 1 °C for every 175 m (574 ft) increase in altitude above 900 m (2,953 ft)
 - Server off: 5°C to 45°C (41°F to 113°F)
 - Shipment/Storage: -40 °C to 60 °C (-40 °F to 140 °F)
- Maximum altitude: 3,050 m (10,000 ft)
- Relative Humidity (non-condensing):
 - Operating:
 - ASHRAE Class A2: 8% - 80%, maximum dew point: 21°C (70°F)
 - ASHRAE Class A3: 8% - 85%, maximum dew point: 24°C (75°F)
 - Shipment/Storage: 8% - 90%

Warranty upgrades and post-warranty support

The ThinkSystem SN850 (machine type 7X15) has a 3-year warranty.

Our global network of regional support centers offers consistent, local-language support enabling you to vary response times and level of service to match the criticality of your support needs:

- **Standard Next Business Day** – Best choice for non-essential systems requiring simple maintenance.
- **Premier Next Business Day** – Best choice for essential systems requiring technical expertise from senior-level Lenovo engineers.
- **Premier 24x7 4-Hour Response** – Best choice for systems where maximum uptime is critical.
- **Premier Enhanced Storage Support 24x7 4-Hour Response** – Best choice for storage systems where maximum uptime is critical.

For more information, consult the brochure [Lenovo Operational Support Services for Data Centers Services](#).

Services

Lenovo Data Center Services empower you at every stage of your IT lifecycle. From expert advisory and strategic planning to seamless deployment and ongoing support, we ensure your infrastructure is built for success. Our comprehensive services accelerate time to value, minimize downtime, and free your IT staff to focus on driving innovation and business growth.

Note: Some service options may not be available in all markets or regions. For more information, go to <https://lenovolocator.com/>. For information about Lenovo service upgrade offerings that are available in your region, contact your local Lenovo sales representative or business partner.

In this section:

- [Lenovo Advisory Services](#)
- [Lenovo Plan & Design Services](#)
- [Lenovo Deployment, Migration, and Configuration Services](#)
- [Lenovo Support Services](#)
- [Lenovo Managed Services](#)
- [Lenovo Sustainability Services](#)

Lenovo Advisory Services

Lenovo Advisory Services simplify the planning process, enabling customers to build future-proofed strategies in as little as six weeks. Consultants provide guidance on projects including VM migration, storage, backup and recovery, and cost management to accelerate time to value, improve cost efficiency, and build a flexibly scalable foundation.

- **Assessment Services**

An Assessment helps solve your IT challenges through an onsite, multi-day session with a Lenovo technology expert. We perform a tools-based assessment which provides a comprehensive and thorough review of a company's environment and technology systems. In addition to the technology based functional requirements, the consultant also discusses and records the non-functional business requirements, challenges, and constraints. Assessments help organizations like yours, no matter how large or small, get a better return on your IT investment and overcome challenges in the ever-changing technology landscape.

- **Design Services**

Professional Services consultants perform infrastructure design and implementation planning to support your strategy. The high-level architectures provided by the assessment service are turned into low level designs and wiring diagrams, which are reviewed and approved prior to implementation. The implementation plan will demonstrate an outcome-based proposal to provide business capabilities through infrastructure with a risk-mitigated project plan.

Lenovo Plan & Design Services

Unlock faster time to market with our tailored, strategic design workshops to align solution approaches with your business goals and technical requirements. Leverage our deep solution expertise and end-to-end delivery partnership to meet your goals efficiently and effectively.

Lenovo Deployment, Migration, and Configuration Services

Optimize your IT operations by shifting labor-intensive functions to Lenovo's skilled technicians for seamless on-site or remote deployment, configuration, and migration. Enjoy peace of mind, faster time to value, and comprehensive knowledge sharing with your IT staff, backed by our best-practice methodology.

- **Deployment Services for Storage and ThinkAgile**

A comprehensive range of remote and onsite options tailored specifically for your business needs to ensure your storage and ThinkAgile hardware are fully operational from the start.

- **Hardware Installation Services**

A full-range, comprehensive setup for your hardware, including unpacking, inspecting, and positioning components to ensure your equipment is operational and error-free for the most seamless and efficient installation experience, so you can quickly benefit from your investments.

- **DM/DG File Migration Services**

Take the burden of file migration from your IT's shoulders. Our experts will align your requirements and business objectives to the migration plans while coordinating with your team to plan and safely execute the data migration to your storage platforms.

- **DM/DG/DE Health Check Services**

Our experts perform proactive checks of your Firmware and system health to ensure your machines are operating at peak and optimal efficiency to maximize up-time, avoid system failures, ensure the security of IT solutions and simplify maintenance.

- **Factory Integrated Services**

A suite of value-added offerings provided during the manufacturing phase of a server or storage system that reduces time to value. These services aim at improving your hardware deployment experience and enhance the quality of a standard configuration before it arrives at your facility.

Lenovo Support Services

In addition to response time options for hardware parts, repairs, and labor, Lenovo offers a wide array of additional support services to ensure your business is positioned for success and longevity. Our goal is to reduce your capital outlays, mitigate your IT risks, and accelerate your time to productivity.

- **Premier Support for Data Centers**

Your direct line to the solution that promises the best, most comprehensive level of support to help you fully unlock the potential of your data center.

- **Premier Enhanced Storage Support (PESS)**

Gain all the benefits of Premier Support for Data Centers, adding dedicated storage specialists and resources to elevate your storage support experience to the next level.

- **Committed Service Repair (CSR)**

Our commitment to ensuring the fastest, most seamless resolution times for mission-critical systems that require immediate attention to ensure minimal downtime and risk for your business. This service is only available for machines under the Premier 4-Hour Response SLA.

- **Multivendor Support Services (MVS)**

Your single point of accountability for resolution support across vast range of leading Server, Storage, and Networking OEMs, allowing you to manage all your supported infrastructure devices seamlessly from a single source.

- **Keep Your Drive (KYD)**

Protect sensitive data and maintain compliance with corporate retention and disposal policies to ensure your data is always under your control, regardless of the number of drives that are installed in your Lenovo server.

- **Technical Account Manager (TAM)**

Your single point of contact to expedite service requests, provide status updates, and furnish reports to track incidents over time, ensuring smooth operations and optimized performance as your business grows.

- **Enterprise Software Support (ESS)**

Gain comprehensive, single-source, and global support for a wide range of server operating systems and Microsoft server applications.

For more information, consult the brochure [Lenovo Operational Support Services for Data Centers](#).

Lenovo Managed Services

Achieve peak efficiency, high security, and minimal disruption with Lenovo's always-on Managed Services. Our real-time monitoring, 24x7 incident response, and problem resolution ensure your infrastructure operates seamlessly. With quarterly health checks for ongoing optimization and innovation, Lenovo's remote active monitoring boosts end-user experience and productivity by keeping your data center's hardware performing at its best.

Lenovo Managed Services provides continuous 24x7 remote monitoring (plus 24x7 call center availability) and proactive management of your data center using state-of-the-art tools, systems, and practices by a team of highly skilled and experienced Lenovo services professionals.

Quarterly reviews check error logs, verify firmware & OS device driver levels, and software as needed. We'll also maintain records of latest patches, critical updates, and firmware levels, to ensure you systems are providing business value through optimized performance.

Lenovo Sustainability Services

- **Asset Recovery Services**

Lenovo Asset Recovery Services (ARS) provides a secure, seamless solution for managing end-of-life IT assets, ensuring data is safely sanitized while contributing to a more circular IT lifecycle. By maximizing the reuse or responsible recycling of devices, ARS helps businesses meet sustainability goals while recovering potential value from their retired equipment. For more information, see the [Asset Recovery Services offering page](#).

- **CO2 Offset Services**

Lenovo's CO2 Offset Services offer a simple and transparent way for businesses to take tangible action on their IT footprint. By integrating CO2 offsets directly into device purchases, customers can easily support verified climate projects and track their contributions, making meaningful progress toward their sustainability goals without added complexity.

- **Lenovo Certified Refurbished**

Lenovo Certified Refurbished offers a cost-effective way to support IT circularity without compromising on quality and performance. Each device undergoes rigorous testing and certification, ensuring reliable performance and extending its lifecycle. With Lenovo's trusted certification, you gain peace of mind while making a more sustainable IT choice.

Lenovo TruScale

Lenovo TruScale XaaS is your set of flexible IT services that makes everything easier. Streamline IT procurement, simplify infrastructure and device management, and pay only for what you use – so your business is free to grow and go anywhere.

Lenovo TruScale is the unified solution that gives you simplified access to:

- The industry's broadest portfolio – from pocket to cloud – all delivered as a service
- A single-contract framework for full visibility and accountability
- The global scale to rapidly and securely build teams from anywhere
- Flexible fixed and metered pay-as-you-go models with minimal upfront cost
- The growth-driving combination of hardware, software, infrastructure, and solutions – all from one single provider with one point of accountability.

For information about Lenovo TruScale offerings that are available in your region, contact your local Lenovo sales representative or business partner.

Regulatory compliance

The server conforms to the following standards:

- ASHRAE Class A3
- FCC - Verified to comply with Part 15 of the FCC Rules Class A
- Canada ICES-004, issue 3 Class A
- UL/IEC 60950-1
- CSA C22.2 No. 60950-1
- Japan VCCI, Class A
- IEC 60950-1 (CB Certificate and CB Test Report)
- Taiwan BSMI CNS13438, Class A; CNS14336
- Australia/New Zealand AS/NZS CISPR 22, Class A
- Korea KN22, Class A, KN24
- IEC 60950-1 (CB Certificate and CB Test Report)
- CE Mark (EN55022 Class A, EN60950-1, EN55024, EN61000-3-2, EN61000-3-3)
- TUV-GS (EN60950-1/IEC 60950-1, EK1-ITB2000)

Lenovo Financial Services

Why wait to obtain the technology you need now? No payments for 90 days and predictable, low monthly payments make it easy to budget for your Lenovo solution.

- **Flexible**

Our in-depth knowledge of the products, services and various market segments allows us to offer greater flexibility in structures, documentation and end of lease options.

- **100% Solution Financing**

Financing your entire solution including hardware, software, and services, ensures more predictability in your project planning with fixed, manageable payments and low monthly payments.

- **Device as a Service (DaaS)**

Leverage latest technology to advance your business. Customized solutions aligned to your needs. Flexibility to add equipment to support growth. Protect your technology with Lenovo's Premier Support service.

- **24/7 Asset management**

Manage your financed solutions with electronic access to your lease documents, payment histories, invoices and asset information.

- **Fair Market Value (FMV) and \$1 Purchase Option Leases**

Maximize your purchasing power with our lowest cost option. An FMV lease offers lower monthly payments than loans or lease-to-own financing. Think of an FMV lease as a rental. You have the flexibility at the end of the lease term to return the equipment, continue leasing it, or purchase it for the fair market value. In a \$1 Out Purchase Option lease, you own the equipment. It is a good option when you are confident you will use the equipment for an extended period beyond the finance term. Both lease types have merits depending on your needs. We can help you determine which option will best meet your technological and budgetary goals.

Ask your Lenovo Financial Services representative about this promotion and how to submit a credit application. For the majority of credit applicants, we have enough information to deliver an instant decision and send a notification within minutes.

Related publications and links

For more information, see the following resources:

- ThinkSystem SN850 server product page
<https://www.lenovo.com/us/en/data-center/servers/flex-blade-servers/compute-nodes/ThinkSystem-SN850/p/77XX7FSFS85>
- Interactive 3D Tour of the ThinkSystem SN850
<https://lenovopress.com/lp0669-3d-tour-thinksystem-sn850>
- ThinkSystem SN850 drivers and support
<http://datacentersupport.lenovo.com/products/servers/thinksystem/sn850/7x15/downloads>
- Lenovo ThinkSystem SN850 product publications:
https://thinksystem.lenovofiles.com/help/topic/7X15/introduction.html?cp=1_1
 - Quick Start
 - Rack Installation Guide
 - Setup Guide
 - Hardware Maintenance Manual
 - Messages and Codes Reference
 - Memory Population Reference
- Lenovo Hardware Installation & Removal Videos on the ThinkSystem SN850:
 - YouTube: <https://www.youtube.com/playlist?list=PLYV5R7hVcs-DtV8A4UWy7d3AoFKjCvas3>
 - Youku: https://list.youku.com/albumlist/show/id_50481024
- Flex System Information Center
<http://flexsystem.lenovofiles.com/help/index.jsp>
- Operating System Interoperability Guide for SN850
<https://lenovopress.com/osig#servers=SN850&support=all>
- Flex System Interoperability Guide
<https://lenovopress.com/fsig>
- Support Portal for the SN850
<https://datacentersupport.lenovo.com/us/en/>

Related product families

Product families related to this document are the following:

- [Blade Servers](#)
- [ThinkSystem SN850 Server](#)

Notices

Lenovo may not offer the products, services, or features discussed in this document in all countries. Consult your local Lenovo representative for information on the products and services currently available in your area. Any reference to a Lenovo product, program, or service is not intended to state or imply that only that Lenovo product, program, or service may be used. Any functionally equivalent product, program, or service that does not infringe any Lenovo intellectual property right may be used instead. However, it is the user's responsibility to evaluate and verify the operation of any other product, program, or service. Lenovo may have patents or pending patent applications covering subject matter described in this document. The furnishing of this document does not give you any license to these patents. You can send license inquiries, in writing, to:

Lenovo (United States), Inc.
8001 Development Drive
Morrisville, NC 27560
U.S.A.
Attention: Lenovo Director of Licensing

LENOVO PROVIDES THIS PUBLICATION "AS IS" WITHOUT WARRANTY OF ANY KIND, EITHER EXPRESS OR IMPLIED, INCLUDING, BUT NOT LIMITED TO, THE IMPLIED WARRANTIES OF NON-INFRINGEMENT, MERCHANTABILITY OR FITNESS FOR A PARTICULAR PURPOSE. Some jurisdictions do not allow disclaimer of express or implied warranties in certain transactions, therefore, this statement may not apply to you.

This information could include technical inaccuracies or typographical errors. Changes are periodically made to the information herein; these changes will be incorporated in new editions of the publication. Lenovo may make improvements and/or changes in the product(s) and/or the program(s) described in this publication at any time without notice.

The products described in this document are not intended for use in implantation or other life support applications where malfunction may result in injury or death to persons. The information contained in this document does not affect or change Lenovo product specifications or warranties. Nothing in this document shall operate as an express or implied license or indemnity under the intellectual property rights of Lenovo or third parties. All information contained in this document was obtained in specific environments and is presented as an illustration. The result obtained in other operating environments may vary. Lenovo may use or distribute any of the information you supply in any way it believes appropriate without incurring any obligation to you.

Any references in this publication to non-Lenovo Web sites are provided for convenience only and do not in any manner serve as an endorsement of those Web sites. The materials at those Web sites are not part of the materials for this Lenovo product, and use of those Web sites is at your own risk. Any performance data contained herein was determined in a controlled environment. Therefore, the result obtained in other operating environments may vary significantly. Some measurements may have been made on development-level systems and there is no guarantee that these measurements will be the same on generally available systems. Furthermore, some measurements may have been estimated through extrapolation. Actual results may vary. Users of this document should verify the applicable data for their specific environment.

© Copyright Lenovo 2025. All rights reserved.

This document, LP0638, was created or updated on February 2, 2021.

Send us your comments in one of the following ways:

- Use the online Contact us review form found at:
<https://lenovopress.lenovo.com/LP0638>
- Send your comments in an e-mail to:
comments@lenovopress.com

This document is available online at <https://lenovopress.lenovo.com/LP0638>.

Trademarks

Lenovo and the Lenovo logo are trademarks or registered trademarks of Lenovo in the United States, other countries, or both. A current list of Lenovo trademarks is available on the Web at <https://www.lenovo.com/us/en/legal/copytrade/>.

The following terms are trademarks of Lenovo in the United States, other countries, or both:

Lenovo®
System x®
ThinkAgile®
ThinkServer®
ThinkSystem®
XClarity®

The following terms are trademarks of other companies:

Intel®, Intel Optane®, and Xeon® are trademarks of Intel Corporation or its subsidiaries.

Linux® is the trademark of Linus Torvalds in the U.S. and other countries.

Microsoft®, ActiveX®, Hyper-V®, PowerShell, Windows PowerShell®, Windows Server®, and Windows® are trademarks of Microsoft Corporation in the United States, other countries, or both.

IBM®, IBM Security®, and Interconnect® are trademarks of IBM in the United States, other countries, or both.

Other company, product, or service names may be trademarks or service marks of others.