

## Five Highlights of the ThinkSystem SR850

### Article

The Lenovo ThinkSystem SR850 is designed for exceptional price performance and flexibility to grow with business needs. The ThinkSystem SR850 gives customers the flexibility to configure for performance and reliability along with high memory and storage capacity. Let's take a look at five highlights of the SR850.



Figure 1. Lenovo ThinkSystem SR850

### 1. Density

A dense server allows more processing and storage capabilities in same amount of data center space. As companies grow, so too do their hardware needs and with them the need for someplace to store all of that hardware. Acquiring new space through expansion of the data center or the creation of new data centers can be expensive, disruptive, and sometimes impossible.

The SR850 provides up to 4 sockets, 48 DIMM slots, 10 PCIe slots, and 16 HDD/SSDs all in a dense 2U design commonly found in 4U rack systems twice the size.

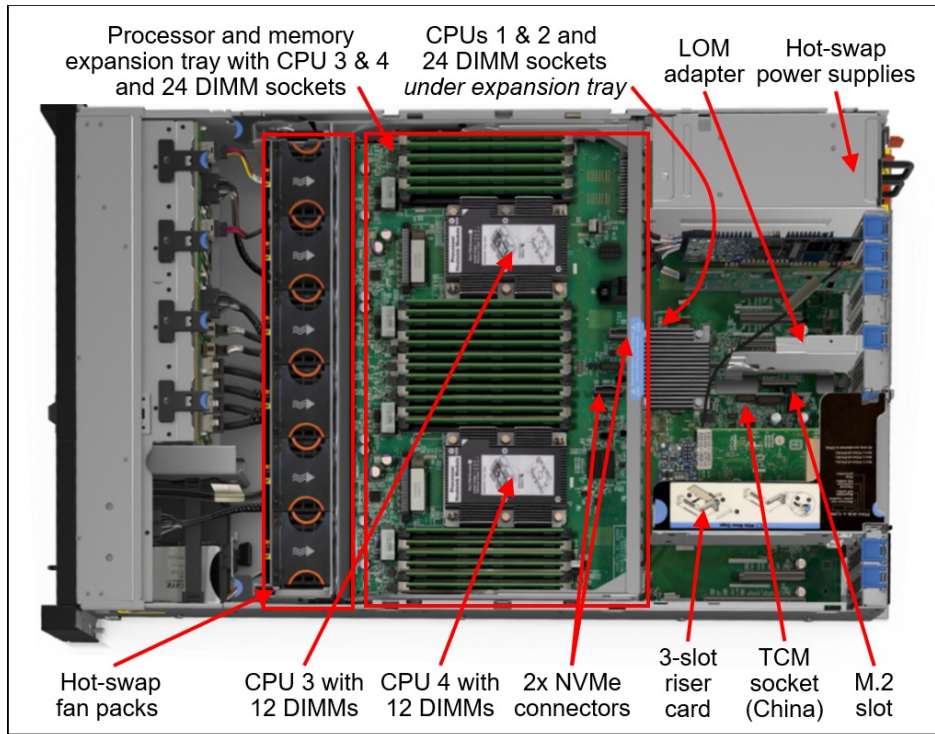

Figure 2. Internal view of the Lenovo ThinkSystem SR850

## 2. Processor and Memory Scalability

The flexible ThinkSystem SR850 server can scale from two to four second-generation Intel Xeon Gold or Platinum processors, delivering significantly faster performance than the previous generation. Built for standard workloads like general business applications and server consolidation, it can also accommodate high-growth areas such as databases and virtualization.

The SR850 supports Gold and Platinum level processors in the second-generation Intel Xeon Processor Scalable Family. Processors supported have up to 28 cores, core speeds of up to 3.8GHz, and TDP ratings of up to 205W. The SR850's processor mezzanine tray design enables you to start with two processors and 24 DIMM sockets and upgrade to four processors and 48 DIMM sockets when you need it, helping lower initial costs and manage growth.

The ThinkSystem SR850 supports standard DRAM memory in addition to the new Intel Optane DC Persistent Memory, delivering a new, flexible tier of memory designed specifically for data center workloads that offer an unprecedented combination of high-capacity, affordability and persistence. This technology will have a significant impact on real-world data center operations: reduction of restart times from minutes down to seconds, 1.2x virtual machine density, dramatically improved data replication with 14x lower latency and 14x higher IOPS, and greater security for persistent data built into hardware.

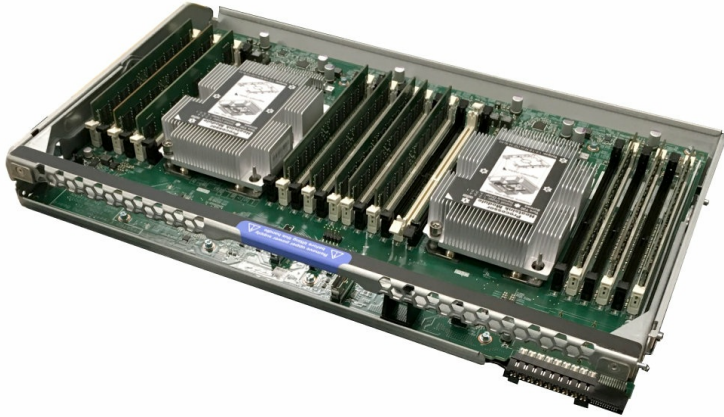

Figure 3. SR850 Processor and Memory Expansion Tray

### 3. Storage Flexibility

The ThinkSystem SR850 has space for 16x 2.5-inch drive bays, up to 8 of which can be configured as AnyBay drives - supporting SAS, SATA or NVMe drives. These choices provide the flexibility and scalability to meet your increasing storage needs.

Storage performance is increased with the use of up to 16 solid-state drives (SSDs) instead of traditional spinning drives (HDDs), which can improve I/O performance. An SSD can support up to 100 times more I/O operations per second (IOPS) than a typical HDD. The SR850 supports up to 8 NVMe PCIe SSDs in a 2.5-inch form factor. NVMe SSDs maximize drive I/O performance, in terms of throughput, bandwidth, and latency.

New high-speed RAID controllers from Broadcom provide 12 Gb SAS connectivity to the drive backplanes. A variety of RAID adapters are available, with cache up to 4 TB and support for 16 drives on a single controller.

Also supported is a new Lenovo patented-design M.2 adapter for convenient operating system boot functions. Available M.2 adapters support either one M.2 drive or two M.2 drives in a RAID 1 configuration for boot drive performance and reliability.

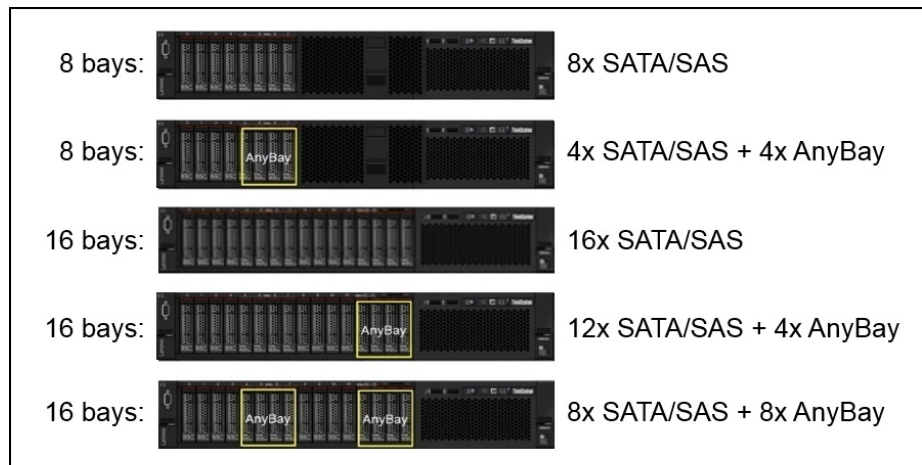

Figure 4. Drive bay configurations

## 4. Flexible Networking

The ThinkSystem SR850 supports up to 10 rear slots, 9 general purpose PCIe 3.0 slots, and dedicated flexible LAN-on-motherboard (LOM) slot. Seven slots are on the system board and three are through a riser card. All slots are available with two processors.

The dedicated LOM slot supports a variety of 10 GbE or Gigabit Ethernet adapters that do not occupy one of the standard PCIe slots. The SR850 supports six different LOM cards which provide the Ethernet PHY function. Only 1 LOM card can be installed. The LOM card supports NC-SI to allow the network connection to be shared between the operating system and the XClarity Controller (XCC) management module (also known as IMM, short for integrated management module). The LOM also supports Wake-on-LAN (WOL).

The SR850 also supports a ML2 adapters provided a suitable ML2 riser card is installed. The ML2 card also supports NC-SI and WOL. Eight different ML2 adapters are offered including Gigabit, 10Gb Ethernet, 25Gb Ethernet and InfiniBand adapters.

The server offers PCI Express 3.0 I/O expansion capabilities that improve the theoretical maximum bandwidth by almost 100 compared to the previous generation of PCI Express 2.0.

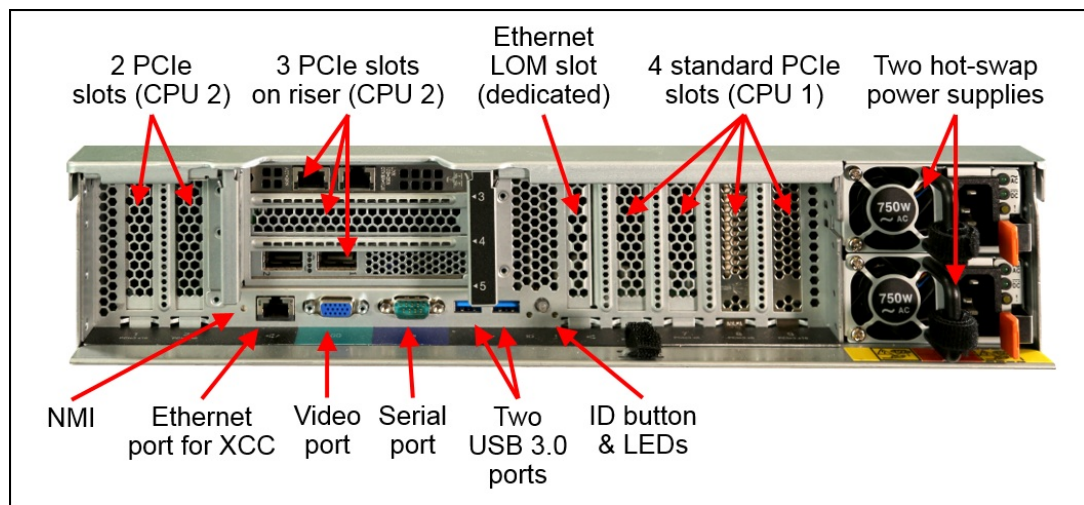

Figure 5. Rear view of the Lenovo ThinkSystem SR850

## 5. Reliability and Availability

Any outage of the mission or business critical server infrastructure results in reduced revenue, reduced profitability, reduced employee productivity, and reduced customer loyalty. Any interruption in the operation or availability of these workloads will have a ripple effect throughout the organization because downtime interferes with business and interrupts business continuity. That means that critical workloads must run on highly reliable and available platforms to ensure that business processes are running smoothly.

The ThinkSystem SR850 provides many features to increase system uptime and simplify serviceability:

- The SR850 features advanced reliability, availability and serviceability (RAS) features. Including Intel “Run Sure” and Lenovo unique Predictive Failure Analysis (PFA).
- The server offers Single Device Data Correction (SDDC) Adaptive Double- Device Data Correction (ADDDC), memory mirroring, and memory rank sparing for redundancy in the event of a non-correctable memory failure.
- The server offers hot-swap drives, supporting RAID redundancy for data protection and greater system uptime.
- The Dual M.2 Boot Adapter supports RAID-1 which enables two installed M.2 drives to be configured as a redundant pair.

- The server has up to two hot-swap redundant power supplies and six hot-swap redundant fans to provide availability for business-critical applications.
- The power-source-independent Light Path Diagnostics uses LEDs to lead the technician to failed (or failing) components, which simplifies servicing, speeds up problem resolution, and helps improve system availability.
- The optional LCD system information display panel provides more detailed diagnostics by displaying all error messages and VPD data needed for a service call, thereby aiding with problem resolution and system uptime.
- Proactive Platform Alerts can be surfaced through the XClarity Controller to managers such as Lenovo XClarity Administrator, VMware vCenter, and Microsoft System Center. These proactive alerts let you take appropriate actions in advance of possible failure, thereby increasing server uptime and application availability.
- The built-in XClarity Controller continuously monitors system parameters, triggers alerts, and performs recovery actions in case of failures to minimize downtime.
- Built-in diagnostics in UEFI, using Lenovo XClarity Provisioning Manager, speed up troubleshooting tasks to reduce service time.

## Further reading

For further reading, see these resources:

- [Lenovo Press product guide on the SR850](#)
- [SR850 product web page](#)

This article is one in a series on the ThinkSystem SR950 and SR850 servers:

- [Five Highlights of the ThinkSystem SR950](#)
- **[Five Highlights of the ThinkSystem SR850](#)**
- [Choosing between Lenovo ThinkSystem SR850 and SR950](#)
- [Workloads for 4-Socket and 8-Socket Servers](#)
- [Usability in the Design of the ThinkSystem SR950](#)
- [The Value of Refreshing Your 4-Socket Servers with the ThinkSystem SR950](#)
- [ThinkSystem SR950 Memory Decisions](#)
- [ThinkSystem SR950 Server Configurations](#)
- [The Value of Refreshing Your 8-Socket Servers with the ThinkSystem SR950](#)
- [Lenovo ThinkSystem SR950 New Options and Features - December 2017](#)
- [ThinkSystem SR950 Performance Leadership](#)
- [Lenovo Servers for Mission Critical Workloads](#)
- [Microsoft and Lenovo ThinkSystem SR950 – A Perfect Match](#)
- [Accelerate Your 4- and 8-Socket Server Refresh Cycle](#)
- [SAP Business Process Applications and Lenovo ThinkSystem SR950 – A Perfect Match](#)
- [ThinkSystem SR950 New Options - March 2018](#)
- [SAP HANA and Lenovo ThinkSystem SR950 – A Perfect Match](#)
- [ThinkSystem SR950 Performance Leadership Continues](#)
- [New Solution for SAP HANA - Lenovo ThinkAgile HX](#)
- [The Advantages of Keeping Mission Critical Workloads On-Premises vs Going to the Cloud](#)
- [SQL Server Migration and Lenovo ThinkSystem SR950](#)

## About the author

Randall Lundin is a Senior Product Manager in the Lenovo Infrastructure Solution Group. He is responsible for planning and managing ThinkSystem servers. Randall has also authored and contributed to numerous Lenovo Press publications on ThinkSystem products.

## Related product families

Product families related to this document are the following:

- [4-Socket Rack Servers](#)
- [ThinkSystem SR850 Server](#)

## Notices

Lenovo may not offer the products, services, or features discussed in this document in all countries. Consult your local Lenovo representative for information on the products and services currently available in your area. Any reference to a Lenovo product, program, or service is not intended to state or imply that only that Lenovo product, program, or service may be used. Any functionally equivalent product, program, or service that does not infringe any Lenovo intellectual property right may be used instead. However, it is the user's responsibility to evaluate and verify the operation of any other product, program, or service. Lenovo may have patents or pending patent applications covering subject matter described in this document. The furnishing of this document does not give you any license to these patents. You can send license inquiries, in writing, to:

Lenovo (United States), Inc.  
8001 Development Drive  
Morrisville, NC 27560  
U.S.A.  
Attention: Lenovo Director of Licensing

LENOVO PROVIDES THIS PUBLICATION "AS IS" WITHOUT WARRANTY OF ANY KIND, EITHER EXPRESS OR IMPLIED, INCLUDING, BUT NOT LIMITED TO, THE IMPLIED WARRANTIES OF NON-INFRINGEMENT, MERCHANTABILITY OR FITNESS FOR A PARTICULAR PURPOSE. Some jurisdictions do not allow disclaimer of express or implied warranties in certain transactions, therefore, this statement may not apply to you.

This information could include technical inaccuracies or typographical errors. Changes are periodically made to the information herein; these changes will be incorporated in new editions of the publication. Lenovo may make improvements and/or changes in the product(s) and/or the program(s) described in this publication at any time without notice.

The products described in this document are not intended for use in implantation or other life support applications where malfunction may result in injury or death to persons. The information contained in this document does not affect or change Lenovo product specifications or warranties. Nothing in this document shall operate as an express or implied license or indemnity under the intellectual property rights of Lenovo or third parties. All information contained in this document was obtained in specific environments and is presented as an illustration. The result obtained in other operating environments may vary. Lenovo may use or distribute any of the information you supply in any way it believes appropriate without incurring any obligation to you.

Any references in this publication to non-Lenovo Web sites are provided for convenience only and do not in any manner serve as an endorsement of those Web sites. The materials at those Web sites are not part of the materials for this Lenovo product, and use of those Web sites is at your own risk. Any performance data contained herein was determined in a controlled environment. Therefore, the result obtained in other operating environments may vary significantly. Some measurements may have been made on development-level systems and there is no guarantee that these measurements will be the same on generally available systems. Furthermore, some measurements may have been estimated through extrapolation. Actual results may vary. Users of this document should verify the applicable data for their specific environment.

© Copyright Lenovo 2024. All rights reserved.

This document, LP0735, was created or updated on May 15, 2019.

Send us your comments in one of the following ways:

- Use the online Contact us review form found at:  
<https://lenovopress.lenovo.com/LP0735>
- Send your comments in an e-mail to:  
[comments@lenovopress.com](mailto:comments@lenovopress.com)

This document is available online at <https://lenovopress.lenovo.com/LP0735>.

## Trademarks

Lenovo and the Lenovo logo are trademarks or registered trademarks of Lenovo in the United States, other countries, or both. A current list of Lenovo trademarks is available on the Web at <https://www.lenovo.com/us/en/legal/copytrade/>.

The following terms are trademarks of Lenovo in the United States, other countries, or both:

Lenovo®

AnyBay®

ThinkAgile®

ThinkSystem®

XClarity®

The following terms are trademarks of other companies:

Intel®, Intel Optane™, and Xeon® are trademarks of Intel Corporation or its subsidiaries.

Microsoft® and SQL Server® are trademarks of Microsoft Corporation in the United States, other countries, or both.

Other company, product, or service names may be trademarks or service marks of others.