

## Lenovo ThinkSystem SR850 V3 Server Product Guide

The Lenovo ThinkSystem SR850 V3 is a 4-socket server that is densely packed into a 2U rack design. The server offers technology advances, including fourth-generation Intel Xeon Scalable processors, and scale-up capacity with up to 16TB of system memory, up to 12x PCIe slots, and up to 24x 2.5-inch drive bays.

Suggested uses: Mission critical scaling up from 2S systems such as enterprise virtualization, CRM, ERP, SQL databases, VDI and small-mid sized SAP HANA computing environments.



Figure 1. Lenovo ThinkSystem SR850 V3

### Did you know?

The Lenovo ThinkSystem SR850 V3 provides the advanced capabilities of four of the new 4th Gen Intel Xeon Scalable processors, however if you wish, you can start with two processors and 32 DIMM slots and then easily expand up to four processors and 64 DIMMs.

The SR850 V3 has space for 24x 2.5-inch drive bays, all 24 of which can be configured as AnyBay drive bays which support SAS, SATA or NVMe drives. NVMe drives are high-speed, low-latency storage, ideal for high-performance local storage or you can mix them with SAS or SATA SSDs or HDDs for storage tiering.

## Key features

The flexible ThinkSystem SR850 V3 server supports 4th Gen Intel Xeon Scalable Gold or Platinum processors and can scale from two to four processors. Built for standard workloads like general business applications and server consolidation, it can also accommodate high-growth areas such as databases and virtualization. The ThinkSystem SR850 V3's agile design permits rapid upgrades for processors and memory, and its large, flexible storage capacity helps to keep pace with data growth.

With the capability to support up to 64 DIMMs, four sockets, up to 24 drives for internal storage, up to 12 PCIe slots, plus two dedicated OCP 3.0 slots for up to 100 GbE networking, the SR850 V3 provides unmatched features and capabilities in a dense 2U rack-mount design.

## Scalability and performance

The SR850 V3 offers numerous features to boost performance, improve scalability and reduce costs:

- Supports two or four 4th Gen Intel Xeon Processor Scalable processors, allowing you to start with two processors and then upgrade to four when you need it.
- Supports Gold and Platinum processors in the Intel Xeon Processor Scalable Family. Processors supported:
  - Up to 60 cores
  - Core speeds of up to 3.7 GHz
  - TDP ratings of up to 350W
- Up to four processors, 240 cores, and 480 threads maximize the concurrent execution of multithreaded applications.
- Support for embedded Intel accelerators:
  - Intel QuickAssist Technology (QAT)
  - Intel Dynamic Load Balancer (DLB)
  - Intel In-Memory Analytics Accelerator (IAA)
  - Intel Data Streaming Accelerator (DSA)
- Enhanced inter-processor communications with three UPI connections between adjacent processors ensures increased CPU I/O throughput.
- Support for up to 64 TruDDR5 memory DIMMs operating at up to 4800 MHz means you have the fastest available memory subsystem and memory capacity of up to 16 TB with 64x 256 GB 3DS RDIMMs.
- Supports configurations of 2 DIMMs per channel to operate at the 4400 MHz rated speed of the memory DIMMs.
- The use of solid-state drives (SSDs) instead of, or along with, traditional spinning drives (HDDs), can improve I/O performance. An SSD can support up to 100 times more I/O operations per second (IOPS) than a typical HDD.
- Up to 24x 2.5-inch drive bays -- supporting combinations of SAS or SATA HDDs, SAS or SATA SSDs, and NVMe PCIe SSDs -- provide a flexible and scalable all-in-one platform to meet your increasing demands. Up to 24x NVMe drives are supported, maximizing drive I/O performance in terms of throughput, bandwidth, and latency.
- The server has a dedicated industry-standard OCP 3.0 small form factor (SFF) slot, with a PCIe 5.0 x16 interface, supporting a variety of Ethernet network adapters. Simple-swap mechanism with thumbscrews and pull-tab enables tool-less installation and removal of the adapter. Supports shared BMC network sideband connectivity to enable out-of-band systems management.
- Up to 12 PCIe slots in addition to the two OCP 3.0 Ethernet slots to maximize I/O capabilities.
- The server is Compute Express Link (CXL) v1.1 Ready. With CXL 1.1 for next-generation workloads, you can reduce compute latency in the data center and lower TCO. CXL is a protocol that runs across the standard PCIe physical layer and can support both standard PCIe devices as well as CXL devices on the same link.

- High-speed RAID controllers from Lenovo and Broadcom provide 12 Gb SAS connectivity to the drive backplanes. A variety of RAID adapters are available, with cache up to 8 GB and support for all 24 drives in the server on a single controller.
- Support for two high-performance double-wide GPUs, or four single-wide GPUs, adding additional processing power to the server.
- Supports up to two externally accessible 7mm hot-swap drives with VROC RAID functionality, in addition to the 24 front drive bays. These 7mm drives are ideal for operating system boot functions.
- As an alternative to the 7mm drives, the server supports an M.2 adapter for convenient operating system boot functions. Available M.2 adapters support VROC RAID for boot drive performance and reliability.
- Supports Intel VROC (Virtual RAID on CPU) which enables basic RAID functionality on the onboard NVMe ports of the server, with no additional adapter needed. This feature enables RAID on NVMe drives (including 7mm and M.2 drives) without the need for a separate RAID adapter.

### **Availability and serviceability**

The SR850 V3 provides many features to simplify serviceability and increase system uptime:

- Designed to run 24 hours a day, 7 days a week
- The server offers Single Device Data Correction (SDDC, also known as Chipkill), Adaptive Double-Device Data Correction (ADDDC, also known as Redundant Bit Steering or RBS), and memory mirroring for redundancy in the event of a non-correctable memory failure.
- The server offers hot-swap drives, supporting RAID redundancy for data protection and greater system uptime.
- Support for VROC to enable RAID-1 support on M.2 or 7mm drives for enhanced data protection of boot drives
- The server two hot-swap redundant power supplies and six N+1 redundant fans to provide availability for business-critical applications.
- The power-source-independent light path diagnostics uses LEDs to lead the technician to failed (or failing) components, which simplifies servicing, speeds up problem resolution, and helps improve system availability.
- Offers a diagnostics port on the front of the server to allow you to attach an external diagnostics handset for enhanced local systems management capabilities. The handset has an LCD display which provides more detailed diagnostics by displaying all error messages and VPD data needed for a service call, thereby aiding with problem resolution and system uptime.
- Proactive Platform Alerts (including PFA and SMART alerts): Processors, voltage regulators, memory, internal storage (SAS/SATA HDDs and SSDs, NVMe SSDs, flash storage adapters), fans, power supplies, RAID controllers, server ambient and subcomponent temperatures. Alerts can be surfaced through the XClarity Controller to managers such as Lenovo XClarity Administrator, VMware vCenter, and Microsoft System Center. These proactive alerts let you take appropriate actions in advance of possible failure, thereby increasing server uptime and application availability.
- Solid-state drives (SSDs) offer more reliability than traditional mechanical HDDs for greater uptime.
- The built-in XClarity Controller continuously monitors system parameters, triggers alerts, and performs recovery actions in case of failures, to minimize downtime.
- Built-in diagnostics in UEFI, using Lenovo XClarity Provisioning Manager, speed up troubleshooting tasks to reduce service time.
- Lenovo XClarity Provisioning Manager collects and saves service data to USB key drive or remote CIFS share folder, for troubleshooting and to reduce service time.
- Auto restart in the event of a momentary loss of AC power (based on the power policy setting in the XClarity Controller service processor)
- Offers a diagnostics port on the front of the server to allow you to attach an external diagnostics

handset for enhanced systems management capabilities.

- Support for the XClarity Administrator Mobile app running on a supported smartphone or tablet and connected to the server through the front USB 2.0 port, enables additional local systems management functions.
- 3-year or 1-year customer-replaceable unit and onsite limited warranty, 9 x 5 next business day. Optional service upgrades are available.

### **Manageability and security**

Powerful systems management features simplify local and remote management of the SR850 V3:

- Lenovo XClarity Controller 2 (XCC2) monitors server availability and performs remote management. XCC2 Platinum is standard, which enables remote KVM, the mounting of remote media files (ISO and IMG image files), boot capture, and power capping.
- Lenovo XClarity Administrator offers comprehensive hardware management tools that help to increase uptime, reduce costs and improve productivity through advanced server management capabilities.
- UEFI-based Lenovo XClarity Provisioning Manager, accessible from F1 during boot, provides system inventory information, graphical UEFI Setup, platform update function, RAID Setup wizard, operating system installation function, and diagnostic functions.
- Support for Lenovo XClarity Energy Manager, which captures real-time power and temperature data from the server and provides automated controls to lower energy costs.
- Root of Trust (RoT) module includes Platform Firmware Resiliency (PFR) and Trusted Platform Module (TPM) 2.0, which further enhances key platform subsystem protections by detecting unauthorized firmware updates, recovering corrupted images to a known-safe image, and monitoring firmware to ensure it has not been compromised. Secures and authenticates system to prevent unauthorized access.
- Integrated Trusted Platform Module (TPM) 2.0 support enables advanced cryptographic methods, such as digital signatures and remote attestation.
- Supports Secure Boot to ensure only a digitally signed operating system can be used. Supported with HDDs and SSDs, as well as 7mm or M.2 drives.
- Industry-standard Advanced Encryption Standard (AES) NI support for faster, stronger encryption.
- Intel Execute Disable Bit functionality can prevent certain classes of malicious buffer overflow attacks when combined with a supported operating system.
- Intel Trusted Execution Technology provides enhanced security through hardware-based resistance to malicious software attacks, allowing an application to run in its own isolated space, protected from all other software running on a system.

## Energy efficiency

The SR850 V3 offers the following energy-efficiency features to save energy, reduce operational costs, and increase energy availability:

- Energy-efficient planar components help lower operational costs.
- High-efficiency power supplies with 80 PLUS Platinum and Titanium certifications
- Intel Intelligent Power Capability turns individual processor elements on and off as needed to reduce power draw.
- Low-voltage 1.1 V DDR5 memory offers energy savings compared to 1.2 V DDR4 DIMMs.
- Solid-state drives (SSDs) consume as much as 80% less power than traditional spinning 2.5-inch HDDs.
- The server uses hexagonal ventilation holes, which can be grouped more densely than round holes, providing more efficient airflow through the system and thus keeping your system cooler.
- Optional Lenovo XClarity Energy Manager provides advanced data center power notification, analysis, and policy-based management to help achieve lower heat output and reduced cooling needs.

## Comparing the SR850 V3 to the SR850 V2

The ThinkSystem SR850 V3 improves on the previous generation SR860 V2, as summarized in the following table.

Table 1. Comparing the SR850 V3 to the SR850 V2

Feature	SR850 V2	SR850 V3	Benefits
Processor	<ul style="list-style-type: none"> <li>• 4x 3rd Gen Intel Xeon Scalable Processors "Cooper Lake"</li> <li>• "Cedar Island" platform</li> <li>• Up to 28 cores</li> <li>• TDP ratings up to 250W</li> <li>• 48x PCIe 3.0 lanes per processor</li> </ul>	<ul style="list-style-type: none"> <li>• 4x 4th Gen Intel Xeon Scalable Processors "Sapphire Rapids"</li> <li>• "Eagle Stream" platform</li> <li>• Up to 60 cores</li> <li>• TDP ratings up to 350W</li> <li>• 80x PCIe 5.0 lanes per processor</li> </ul>	<ul style="list-style-type: none"> <li>• Increased performance by 129% (based on preliminary data from Intel)</li> <li>• Significant increase in cores per processor</li> <li>• Increased performance</li> <li>• Consolidation of more apps on same number of servers, reducing costs</li> <li>• New PCIe 5.0 support means higher performance networking and NVMe storage</li> </ul>
GPU	<ul style="list-style-type: none"> <li>• Supports up to 2x single-wide GPUs</li> </ul>	<ul style="list-style-type: none"> <li>• Supports up to 4x single-wide GPUs or 2x double-wide GPUs</li> </ul>	<ul style="list-style-type: none"> <li>• Increased GPU support</li> <li>• Added double-wide GPU support</li> </ul>

Feature	SR850 V2	SR850 V3	Benefits
Memory	<ul style="list-style-type: none"> <li>• DDR4 memory operating up to 3200 MHz</li> <li>• 6 channels per CPU</li> <li>• 24 DIMMs (12 per processor), 2 DIMMs per channel</li> <li>• Supports RDIMMs and 3DS RDIMMs</li> <li>• Up to 12TB of system memory</li> <li>• Intel Optane Persistent Memory 200 Series</li> </ul>	<ul style="list-style-type: none"> <li>• DDR5 memory operating up to 4800 MHz</li> <li>• 8 channels per CPU</li> <li>• 32 DIMMs (16 per processor), 2 DIMMs per channel</li> <li>• Supports RDIMMs, 3DS RDIMMs and 9x4 RDIMMs</li> <li>• Up to 16TB of system memory</li> <li>• No support for persistent memory</li> </ul>	<ul style="list-style-type: none"> <li>• Increased memory capacity</li> <li>• New DDR5 memory offers significant performance improvements over DDR4</li> <li>• More memory channels means greater memory bandwidth</li> <li>• Support for lower-cost 9x4 DIMMs</li> </ul>
Internal storage	<ul style="list-style-type: none"> <li>• Up to 24x 2.5-inch hot-swap drives</li> <li>• Supports SATA, AnyBay or NVMe backplanes</li> <li>• Up to 24x NVMe drives (PCIe Gen 3)</li> <li>• 16x direct connections</li> <li>• 2x 7mm SATA/NVMe in dedicated bay (HW RAID)</li> </ul>	<ul style="list-style-type: none"> <li>• Up to 24x 2.5-inch hot-swap drives</li> <li>• Supports SATA or AnyBay backplanes</li> <li>• Up to 24x NVMe drives (PCIe Gen 4/Gen 5)</li> <li>• 24x direct connections</li> <li>• 2x 7mm SATA/NVMe in PCIe slot (VROC RAID)</li> <li>• Internal 2x M.2 drives (VROC RAID)</li> <li>• M.2 adapter with NVMe x4 interface</li> <li>• 7mm and M.2 are mutually exclusive</li> </ul>	<ul style="list-style-type: none"> <li>• 2X performance improvement with PCIe Gen5 NVMe</li> <li>• 24 direct connections means no NVMe retimer or switch adapters needed</li> <li>• Added M.2 drive support</li> <li>• x4 M.2 NVMe SSDs for faster boot performance</li> </ul>
RAID	<ul style="list-style-type: none"> <li>• 8-, 16- and 32-port RAID adapters with up to 8GB flash</li> <li>• Support for Lenovo and Broadcom adapters</li> <li>• Storage HBAs available</li> <li>• VROC for NVMe</li> <li>• Onboard SATA with SW RAID</li> </ul>	<ul style="list-style-type: none"> <li>• 8-, 16- and 32-port RAID adapters with up to 8GB flash</li> <li>• Support for Lenovo and Broadcom adapters</li> <li>• Storage HBAs available</li> <li>• VROC for NVMe</li> </ul>	<ul style="list-style-type: none"> <li>• Consistent RAID/HBA support</li> <li>• Flexible config solution</li> <li>• PCIe Gen 5 allows for greater storage performance</li> </ul>
Networking	<ul style="list-style-type: none"> <li>• 1x OCP 3.0 slot with PCIe Gen 3 x16 interface</li> <li>• Additional PCIe adapters supported</li> <li>• 1GbE dedicated Management port</li> </ul>	<ul style="list-style-type: none"> <li>• 2x OCP 3.0 slots with PCIe Gen 5 x16 interfaces</li> <li>• Additional PCIe adapters supported</li> <li>• 1GbE dedicated Management port</li> </ul>	<ul style="list-style-type: none"> <li>• Improved performance with PCIe Gen 5</li> <li>• Support for two OCP adapters in dedicated slots</li> </ul>

Feature	SR850 V2	SR850 V3	Benefits
PCIe	<ul style="list-style-type: none"> <li>• Supports PCIe 3.0</li> <li>• Up to 7x slots (all Gen3)</li> <li>• 2 onboard slots; others via riser cards</li> <li>• 1x OCP slot (PCIe Gen3)</li> </ul>	<ul style="list-style-type: none"> <li>• Supports PCIe 5.0</li> <li>• Up to 12x slots (all Gen4)</li> <li>• Up to 12x slots (mix of Gen4 &amp; Gen5)</li> <li>• All slots via riser cards</li> <li>• 2x OCP slots (PCIe Gen5)</li> </ul>	<ul style="list-style-type: none"> <li>• PCIe Gen 5 allows for greater I/O performance</li> <li>• Additional 5x PCIe slots</li> <li>• Additional OCP slot</li> </ul>
Management and security	<ul style="list-style-type: none"> <li>• XClarity Controller</li> <li>• Support for full XClarity toolset including XClarity Administrator</li> <li>• Platform Firmware Resiliency (PFR) hardware Root of Trust (RoT)</li> <li>• Tamper Switch security solution (intrusion switch)</li> <li>• Integrated diagnostics panel with LCD display</li> </ul>	<ul style="list-style-type: none"> <li>• Integrated XClarity Controller 2</li> <li>• Support for full XClarity toolset including XClarity Administrator</li> <li>• Platform Firmware Resiliency (PFR) hardware Root of Trust (RoT)</li> <li>• Tamper Switch security solution (intrusion switch)</li> <li>• Supports optional external diagnostics handset</li> </ul>	<ul style="list-style-type: none"> <li>• New XCC2 offers improved management capabilities</li> <li>• Same system management tool with previous generation</li> <li>• Silicon-level security solution</li> </ul>
Power	<ul style="list-style-type: none"> <li>• Choice of 750W-2600W AC hot-swap power supplies</li> <li>• Available in Titanium and Platinum efficiency levels</li> <li>• 240V HVDC support for PRC customers</li> <li>• Active-Standby mode</li> </ul>	<ul style="list-style-type: none"> <li>• Choice of 1100-2600W AC hot-swap power supplies</li> <li>• Available in Titanium and Platinum efficiency levels</li> <li>• 240V HVDC support for PRC customers</li> <li>• CRPS power supply support for PRC customers</li> <li>• -48V or 336V DC power supply for PRC customers</li> <li>• Active-Standby mode</li> </ul>	<ul style="list-style-type: none"> <li>• Multiple PSU offerings to suit the configuration selected</li> <li>• New ErP Lot 9-compliant offerings</li> <li>• Support CRPS for PRC</li> </ul>

## Components and connectors

The following figure shows the front of the server.

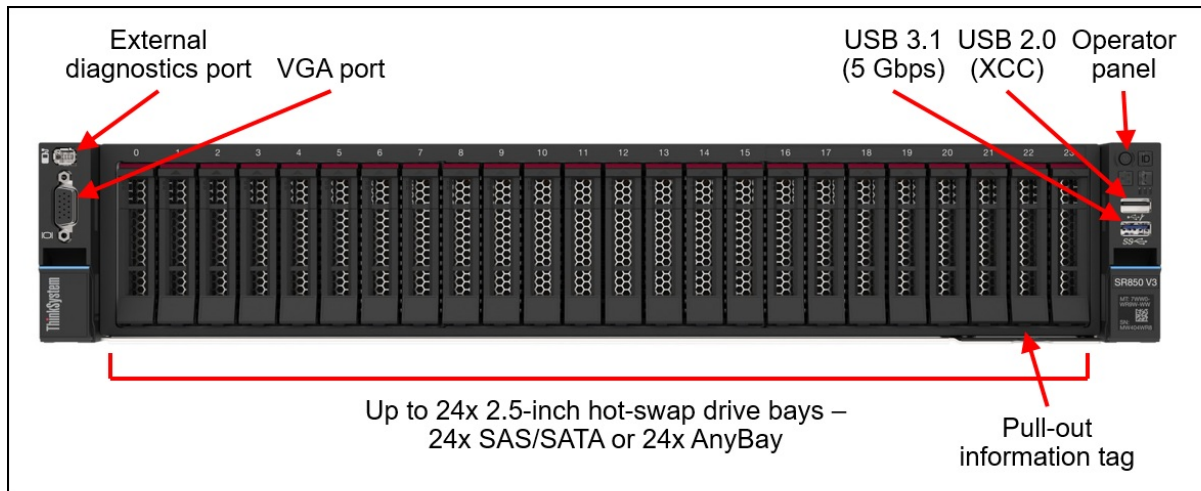

Figure 2. Front view of the ThinkSystem SR850 V3

The following figure shows the rear of the server.

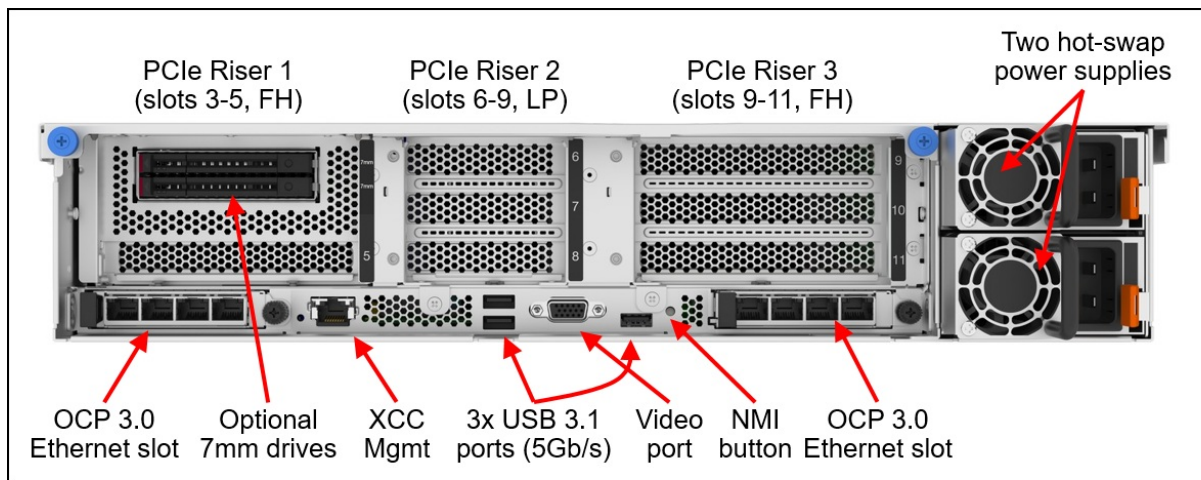

Figure 3. Rear view of the ThinkSystem SR850 V3



The SR850 V3 supports four risers with all low-profile slots, or three risers with a mix of full-height and low-profile slots. The later also supports 7mm drives in the place of two of the slots. The following figure shows all three slot configurations.

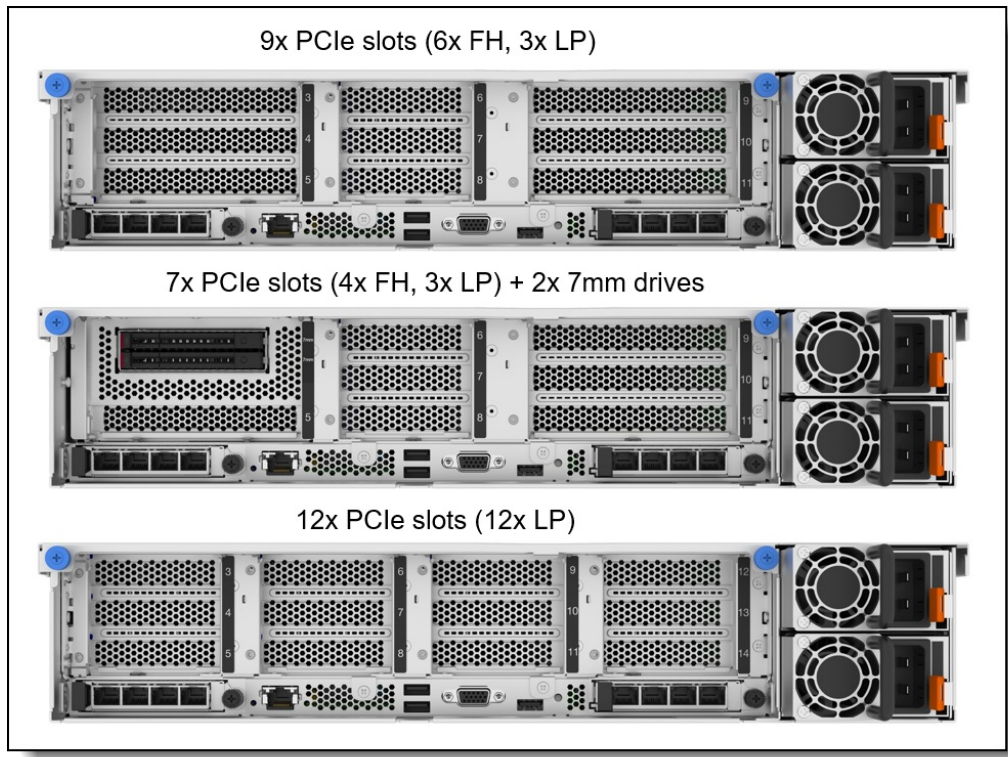

Figure 4. Slot combinations of the ThinkSystem SR850 V3

The following figure shows the locations of key components inside the server.

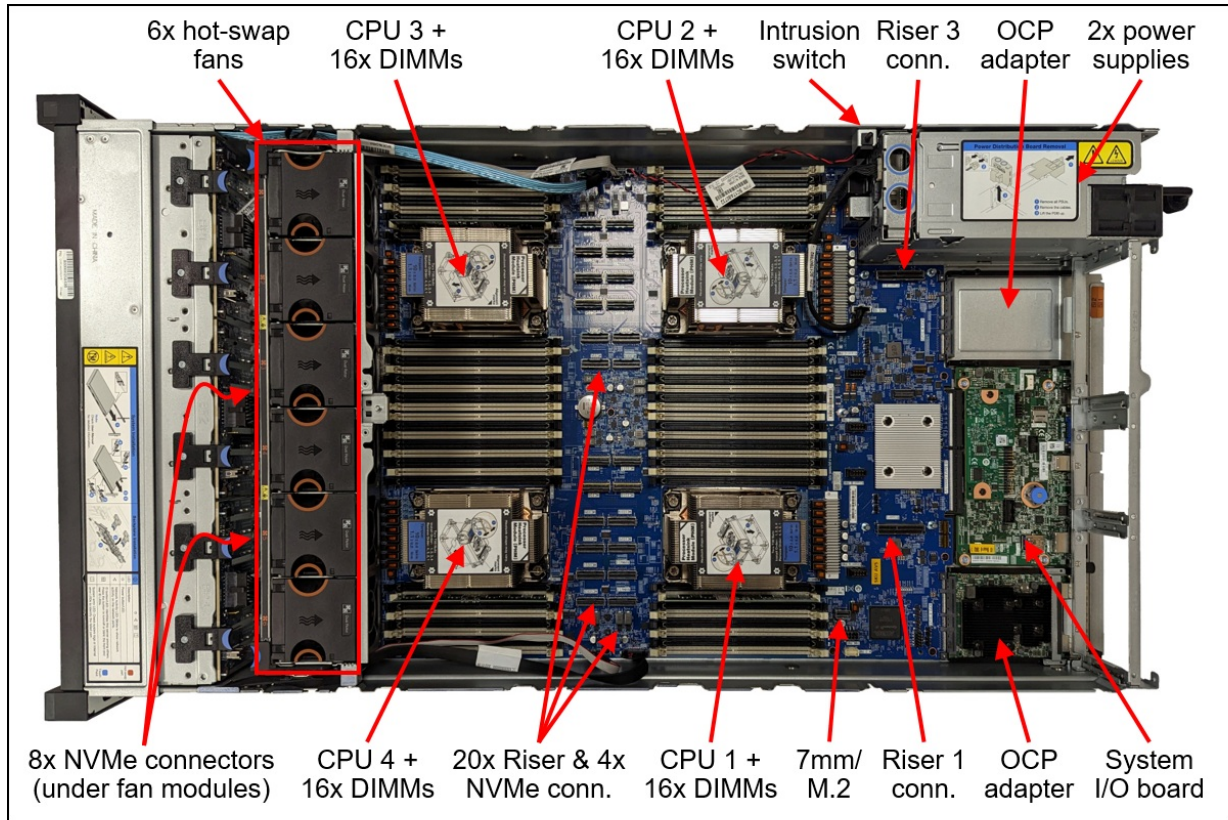

Figure 5. Internal view of the SR850 V3

The following figure shows the inside the server with the air baffles and PCIe risers installed. It also shows the M.2 adapter installed and the location of the RAID adapter supercaps.

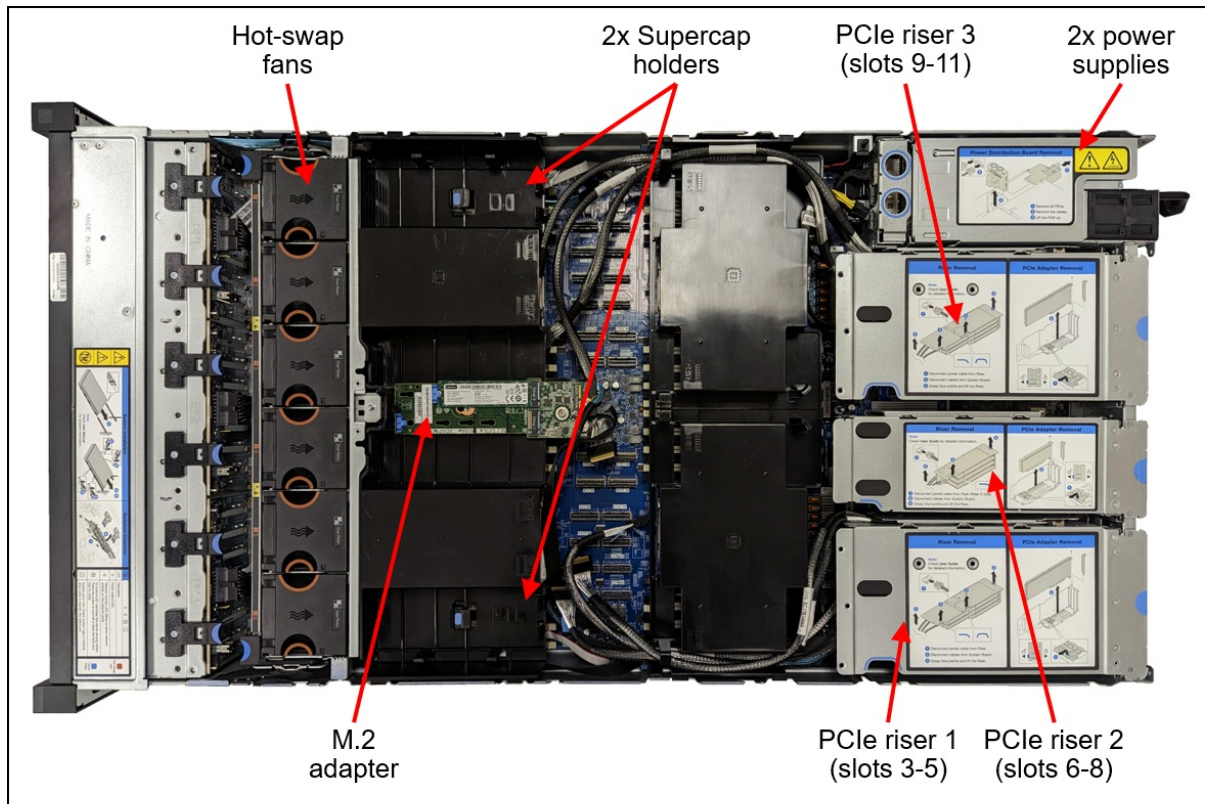

Figure 6. Internal view of the SR850 V3 with M.2 and risers installed

### Standard specifications

The following table lists the standard specifications.

Table 2. Standard specifications

Components	Specification
Machine types	7D96 - 3-year warranty 7D97 - 1-year warranty 7D98 - SAP HANA configurations with 3-year warranty
Form factor	2U rack
Processor	Two or four 4th Gen Intel Xeon Scalable processors, either Gold or Platinum level processors (formerly codename "Sapphire Rapids" or SPR). Supports processors up to 60 cores, core speeds up to 3.7 GHz, and TDP ratings up to 350W. Three Intel Ultra Path Interconnect (UPI) links at 16 GT/s each. Four processors are connected in a mesh topology. Support for Intel embedded accelerators: QAT, DLB, IAA, and DSA.
Chipset	Intel C741 "Emmitsburg" chipset, part of the platform codenamed "Eagle Stream" (EGS)
Memory	Up to 64 DIMM slots (16 DIMMs per processor). Each processor has 8 memory channels, with 2 DIMMs per channel. Lenovo TruDDR5 RDIMMs and 3DS RDIMMs are supported. DIMMs operate at up to 4800 MHz at 1 DPC and 4400 MHz at 2 DPC.
Persistent memory	No support.

Components	Specification
Memory maximums	Up to 16TB with 64x 256GB 3DS RDIMMs and four processors (4.0TB per processor).
Memory protection	ECC, SDDC (for x4-based memory DIMMs), ADDDC (for x4-based memory DIMMs), memory mirroring.
Disk drive bays	Up to 24x 2.5-inch hot-swap drive bays: <ul style="list-style-type: none"> <li>Up to 24x SAS/SATA drive bays</li> <li>Up to 24x AnyBay drive bays (support SAS, SATA, Gen4 NVMe, or Gen5 NVMe drives)</li> </ul> Optional two 7mm hot-swap SSD drive bays at the rear of the server, either SATA or NVMe, for OS boot or storage
Maximum internal storage	737.28TB using 24x 30.72TB 2.5-inch SAS/SATA SSDs 368.64TB using 24x 15.36TB 2.5-inch NVMe SSDs 57.6TB using 24x 2.4TB 2.5-inch HDDs  Mix of NVMe/SSDs/HDDs supported.
Storage controller	<ul style="list-style-type: none"> <li>Up to 24x Onboard PCIe Gen 5 or Gen 4 NVMe ports (RAID functions provided using Intel VROC)</li> <li>12 Gb SAS/SATA RAID adapters</li> <li>12 Gb SAS/SATA non-RAID</li> </ul>
Optical drive bays	No internal optical drive
Tape drive bays	No internal backup drive
Network interfaces	Two dedicated OCP 3.0 SFF slots with PCIe 5.0 x16 host interface. Supports a variety of 2-port and 4-port adapters with network connectivity up to 100 GbE. One port can optionally be shared with the XClarity Controller (XCC) management processor for Wake-on-LAN and NC-SI support.
PCI Expansion slots	Up to 12 PCIe slots, depending on the configuration, plus two Gen5 OCP 3.0 slots. Slot combinations are based on the risers selected: <ul style="list-style-type: none"> <li>With Full height &amp; Low Profile slots: <ul style="list-style-type: none"> <li>Gen 4 only: 9x Gen4</li> <li>Gen 5/Gen 4 slots: 6x Gen5 + 1x Gen4</li> </ul> </li> <li>Low Profile only slots: <ul style="list-style-type: none"> <li>Gen 4 only : 12x Gen4 slots</li> <li>Gen 5/Gen 4 slots: 8x Gen5 + 4x Gen4</li> </ul> </li> </ul> See the <a href="#">I/O expansion</a> section for details.
GPU support	Supports up to 4x single-wide GPUs or up to 2x double-wide GPUs
Ports	<p>Front: One VGA video port. 1x USB 3.2 G1 (5 Gb/s) port, 1x USB 2.0 port. The USB 2.0 port can be configured to support local systems management by using the XClarity Administrator mobile app on a mobile device connected via a USB cable.</p> <p>Rear: Three USB 3.2 G1 (5 Gbp/s) ports, one VGA video port, one RJ-45 XClarity Controller (XCC) systems management port, optional DB-9 serial port. The serial port can be shared with the XCC for serial redirection functions.</p> <p>Internal: Optional M.2 adapter in dedicated slot supporting one or two M.2 drives (for OS boot support, including hypervisor support).</p>

Components	Specification
Cooling	6x N+1 redundant hot-swap 60 mm fans (all 6 standard). One additional fan integrated in each of the two power supplies.
Power supply	Two hot-swap redundant AC power supplies (80 PLUS Platinum or Titanium certification): 1100W to 2600W options, supporting 220 V AC. 1100 W options also support 110V input supply. For China only, supports 1300 W and 2600 W 240V AC/DC Platinum CRPS, or 1600 W 336V DC or -48V DC CRPS. Power supplies can be configured as N+N redundant.
Video	Embedded video graphics with 16 MB memory with 2D hardware accelerator, integrated into the XClarity Controller. Maximum resolution is 1920x1200 32bpp at 60Hz.
Hot-swap parts	Drives, fans and power supplies.
Systems management	Operator panel with status LEDs. Optional External Diagnostics Handset with LCD display. Models with 16x 2.5-inch front drive bays can optionally support an Integrated Diagnostics Panel. XClarity Controller 2 (XCC2) embedded management based on the ASPEED AST2600 baseboard management controller (BMC). Dedicated rear Ethernet port for XCC2 remote access for management. XClarity Administrator for centralized infrastructure management, XClarity Integrator plugins, and XClarity Energy Manager centralized server power management. XCC2 Platinum is included which enables remote control functions and other features.
Security features	Chassis intrusion switch, Power-on password, administrator's password, Root of Trust module supporting TPM 2.0 and Platform Firmware Resiliency (PFR).
Operating systems supported	Microsoft Windows Server, Red Hat Enterprise Linux, SUSE Linux Enterprise Server, VMware ESXi. See the <a href="#">Operating system support</a> section for specifics.
Limited warranty	3-year or 1-year (model dependent) customer-replaceable unit and onsite limited warranty with 9x5 next business day (NBD).
Service and support	Optional service upgrades are available through Lenovo Services: 4-hour or 2-hour response time, 6-hour fix time, 1-year or 2-year warranty extension, software support for Lenovo hardware and some third-party applications. Actual offering may depend on the region where the server is installed and is subject to change.
Dimensions	Width: 447 mm (17.6 in.), height: 87 mm (3.4 in.), depth: 902 mm (35.5 in.). See <a href="#">Physical and electrical specifications</a> for details.
Weight	Maximum: 36.7 kg (80.9 lb)

The SR850 V3 servers are shipped with the following items:

- Documentation flyer
- Rail kit (model dependent)
- Power cords (model and region dependent)

## Models

ThinkSystem SR850 V3 models can be configured by using the [Lenovo Data Center Solution Configurator \(DCSC\)](#).

Configure-to-order (CTO) models are used to create models with factory-integrated server customizations. For CTO models, two types of base CTO models are available for the SR850 V3 as listed in the columns in the following table:

- General purpose base CTO models are for general business (non-HPC) and is selectable by choosing **General Purpose** mode in DCSC.
- AI and HPC base models are intended for Artificial Intelligence (AI) and High Performance

Computing (HPC) configurations and solutions are enabled using the **AI & HPC Hardware - ThinkSystem Hardware** mode in DCSC. These configurations, along with Lenovo EveryScale Solutions, can also be built using [System x and Cluster Solutions Configurator \(x-config\)](#). **Tip:** Some HPC and AI models are not listed in DCSC and can only be configured in x-config.

**Controlled GPU models:** The "Controlled GPU" base CTO models listed in the table are the only models that support high-performance GPUs and accelerators. These models are classified under US Government ECCN regulations and have limited market and customer availability. All other base models do not support high-performance GPUs.

Preconfigured server models may also be available for the SR850 V3, however these are region-specific; that is, each region may define their own server models, and not all server models are available in every region.

The following table lists the base CTO models of the ThinkSystem SR850 V3 server.

Table 3. Base CTO models

Machine Type/Model General purpose	Machine Type/Model for AI and HPC	Description
7D96CTO1WW	7D96CTOLWW	ThinkSystem SR850 V3-3yr Warranty
7D96CTO2WW	7D96CTOHHW	ThinkSystem SR850 V3-3yr Warranty with Controlled GPU
7D97CTO1WW	7D97CTOLWW	ThinkSystem SR850 V3-1yr Warranty
7D98CTO1WW	None	ThinkSystem SR850 V3 – SAP HANA configurations with 3-year warranty

Models are based on a chassis feature code.

**GPU support:** For GPU support (single-wide or double-wide) or full-length adapter support, you *must* select base BT69. The standard bases (BT67 and BT68) do not support these adapters and cannot be upgraded in the field to support full-length adapters or GPUs.

Table 4. Chassis base feature code

Feature code	Description	Purpose
BT67	ThinkSystem SR850 V3 Standard 2U/4S Base with LP PCIe	12x low-profile slots No support for full-length adapters
BT68	ThinkSystem SR850 V3 Standard 2U/4S Base with FH PCIe	6x FHH (full height, half length) slots, 3x low-profile slots No support for full-length adapters
BT69	ThinkSystem SR850 V3 2U/4S Base Supporting GPUs	6x full-height slots, 3x low-profile slots Support for any GPUs (DW or SW) and any full-length adapters

## Processors

The SR850 V3 supports Gold and Platinum level processors in the 4th Gen Intel Xeon Scalable Processor family. The server supports two or four processors.

**Support for three processors:** For configurations with 3 processors, submit a CORE/special bid request.

The four processors are connected together using a mesh topology. A mesh topology allows all four processors to be connected together which improves the performance of processor-to-processor communications. The SR850 V3 implements a mesh topology using 3 UPI links.

Topics in this section:

- [Processor options](#)
- [Processor features](#)
- [Two-processor configurations](#)
- [Thermal requirements by processor](#)
- [UEFI operating modes](#)

### Processor options

All supported processors have the following characteristics:

- 8 DDR5 memory channels at 2 DIMMs per channel
- Up to 3 UPI links between processors at 16 GT/s
- 80 PCIe 5.0 I/O lanes

The following table lists the 4th Gen processors that are currently supported by the SR850 V3.

Table 5. 4th Gen Intel Xeon Processor support

Part number	Feature code	SKU	Description	Maximum quantity
4XG7A86603	BQ6C	6416H	ThinkSystem SR850 V3 Intel Xeon Gold 6416H 18C 165W 2.2GHz Processor Option Kit w/o Fan	4
4XG7A86602	BQ6B	6418H	ThinkSystem SR850 V3 Intel Xeon Gold 6418H 24C 185W 2.1GHz Processor Option Kit w/o Fan	4
4XG7A86604	BQ6E	6434H	ThinkSystem SR850 V3 Intel Xeon Gold 6434H 8C 205W 3.7GHz Processor Option Kit w/o Fan	4
4XG7A86601	BQ6A	6448H	ThinkSystem SR850 V3 Intel Xeon Gold 6448H 32C 225W 2.4GHz Processor Option Kit w/o Fan	4
4XG7A86600	BPPH	8444H	ThinkSystem SR850 V3 Intel Xeon Platinum 8444H 16C 270W 2.9GHz Processor Option Kit w/o Fan	4
4XG7A86599	BPPG	8450H	ThinkSystem SR850 V3 Intel Xeon Platinum 8450H 28C 250W 2.0GHz Processor Option Kit w/o Fan	4
4XG7A86598	BPPF	8454H	ThinkSystem SR850 V3 Intel Xeon Platinum 8454H 32C 270W 2.1GHz Processor Option Kit w/o Fan	4
4XG7A86597	BPPN	8460H	ThinkSystem SR850 V3 Intel Xeon Platinum 8460H 40C 330W 2.2GHz Processor Option Kit w/o Fan	4
4XG7A86596	BPPE	8468H	ThinkSystem SR850 V3 Intel Xeon Platinum 8468H 48C 330W 2.1GHz Processor Option Kit w/o Fan	4
4XG7A86595	BPPS	8490H	ThinkSystem SR850 V3 Intel Xeon Platinum 8490H 60C 350W 1.9GHz Processor Option Kit w/o Fan	4

Configuration notes:

- Processor options include a heatsink but do not include a system fan

## Processor features

Processors supported by the SR850 V3 introduce new embedded accelerators to add even more processing capability:

- QuickAssist Technology (Intel QAT)

Help reduce system resource consumption by providing accelerated cryptography, key protection, and data compression with Intel QuickAssist Technology (Intel QAT). By offloading encryption and decryption, this built-in accelerator helps free up processor cores and helps systems serve a larger number of clients.

- Intel Dynamic Load Balancer (Intel DLB)

Improve the system performance related to handling network data on multi-core Intel Xeon Scalable processors. Intel Dynamic Load Balancer (Intel DLB) enables the efficient distribution of network processing across multiple CPU cores/threads and dynamically distributes network data across multiple CPU cores for processing as the system load varies. Intel DLB also restores the order of networking data packets processed simultaneously on CPU cores.

- Intel Data Streaming Accelerator (Intel DSA)

Drive high performance for storage, networking, and data-intensive workloads by improving streaming data movement and transformation operations. Intel Data Streaming Accelerator (Intel DSA) is designed to offload the most common data movement tasks that cause overhead in data center-scale deployments. Intel DSA helps speed up data movement across the CPU, memory, and caches, as well as all attached memory, storage, and network devices.

- Intel In-Memory Analytics Accelerator (Intel IAA)

Run database and analytics workloads faster, with potentially greater power efficiency. Intel In-Memory Analytics Accelerator (Intel IAA) increases query throughput and decreases the memory footprint for in-memory database and big data analytics workloads. Intel IAA is ideal for in-memory databases, open source databases and data stores like RocksDB, Redis, Cassandra, and MySQL.

- Intel Advanced Matrix Extensions (Intel AMX)

Intel Advanced Matrix Extensions (Intel AMX) is a built-in accelerator in all Silver, Gold, and Platinum processors that significantly improves deep learning training and inference. With Intel AMX, you can fine-tune deep learning models or train small to medium models in just minutes. Intel AMX offers discrete accelerator performance without added hardware and complexity.

The processors also support a separate and encrypted memory space, known as the SGX Enclave, for use by Intel Software Guard Extensions (SGX). The size of the SGX Enclave supported varies by processor model. Intel SGX offers hardware-based memory encryption that isolates specific application code and data in memory. It allows user-level code to allocate private regions of memory (enclaves) which are designed to be protected from processes running at higher privilege levels.

The following table summarizes the key features of all supported 4th Gen processors in the SR850 V3.



Table 6. 4th Gen Intel Xeon Processor features

CPU model	Cores/ threads	Core speed (Base / TB max†)	L3 cache*	Max memory speed	UPI 2.0 links & speed	TDP	Accelerators				SGX Enclave Size
							QAT	DLB	DSA	IAA	
6416H	18 / 36	2.2 / 4.2 GHz	45 MB*	4800 MHz	3 / 16 GT/s	165W	0	0	1	1	512GB
6418H	24 / 48	2.1 / 4.0 GHz	60 MB*	4800 MHz	3 / 16 GT/s	185W	0	0	1	1	512GB
6434H	8 / 16	3.7 / 4.1 GHz	22.5 MB*	4800 MHz	3 / 16 GT/s	195W	0	0	1	1	512GB
6448H	32 / 64	2.4 / 4.1 GHz	60 MB	4800 MHz	3 / 16 GT/s	250W	2	2	1	1	512GB
8444H	16 / 32	2.9 / 4.0 GHz	45 MB*	4800 MHz	3 / 16 GT/s	270W	0	0	4	4	512GB
8450H	28 / 56	2.0 / 3.5 GHz	75 MB*	4800 MHz	3 / 16 GT/s	250W	0	0	4	4	512GB
8454H	32 / 64	2.1 / 3.4 GHz	82.5 MB*	4800 MHz	3 / 16 GT/s	270W	4	4	4	4	512GB
8460H	40 / 80	2.2 / 3.8 GHz	105 MB*	4800 MHz	3 / 16 GT/s	330W	0	0	4	4	512GB
8468H	48 / 96	2.1 / 3.8 GHz	105 MB*	4800 MHz	3 / 16 GT/s	330W	4	4	4	4	512GB
8490H	60 / 120	1.9 / 3.5 GHz	112.5 MB	4800 MHz	3 / 16 GT/s	350W	4	4	4	4	512GB

† The maximum single-core frequency at with the processor is capable of operating

\* L3 cache is 1.875 MB per core or larger. Processors with a larger L3 cache per core are marked with an \*

### Two-processor configurations

The SR850 V3 can be used with only two processors installed. Most core functions of the server (including the XClarity Controller) are connected to processors 1 and 2 as shown in the [System architecture](#) section.

With only two processors, the server has the following capabilities:

- 32 memory DIMMs for an 8TB maximum
- Slots: 5 slots (FHHL) or 6 slots (HHHL)
- NVMe drives: 8 NVMe drives
- GPUs: 4x single-wide GPUs (no double-wide GPUs)

### Thermal requirements by processor

The following thermal requirements apply to the SR850 V3:

- Servers with DW GPUs and full-length adapters: Processors with TDP 165W or lower

The use of full-length PCIe adapter (for example double-wide GPUs) requires the use of the 1U heatsink for the rear processors. These heatsinks limit the processors to 165W TDP or less.

### UEFI operating modes

The SR850 V3 offers preset operating modes that affect energy consumption and performance. These modes are a collection of predefined low-level UEFI settings that simplify the task of tuning the server to suit your business and workload requirements.

The following table lists the feature codes that allow you to specify the mode you wish to preset in the factory for CTO orders.

Table 7. UEFI operating mode presets in DCSC

Feature code	Description
BFYB	Operating mode selection for: "Maximum Performance Mode"
BFYC	Operating mode selection for: "Minimal Power Mode"
BFYD	Operating mode selection for: "Efficiency Favoring Power Savings Mode"
BFYE	Operating mode selection for: "Efficiency - Favoring Performance Mode"

The preset modes for the SR850 V3 are as follows:

- **Maximum Performance Mode** (feature BFYB): Achieves maximum performance but with higher power consumption and lower energy efficiency.
- **Minimal Power Mode** (feature BFYC): Minimize the absolute power consumption of the system.
- **Efficiency Favoring Power Savings Mode** (feature BFYD): Maximize the performance/watt efficiency with a bias towards power savings. This is the favored mode for SPECpower benchmark testing, for example.
- **Efficiency Favoring Performance Mode** (feature BFYE): Maximize the performance/watt efficiency with a bias towards performance. This is the favored mode for Energy Star certification, for example.

For details about these preset modes, and all other performance and power efficiency UEFI settings offered in the SR850 V3, see the paper "Tuning UEFI Settings for Performance and Energy Efficiency on Intel Xeon Scalable Processor-Based ThinkSystem Servers", available from <https://lenovopress.lenovo.com/lp1477>.

## Memory options

The SR850 V3 uses Lenovo TruDDR5 memory operating at up to 4800 MHz. The server supports up to 64 DIMMs with 4 processors. The processors have 8 memory channels and support 2 DIMMs per channel (DPC). The server supports up to 16TB of memory using 64x 256GB 3DS RDIMMs and four processors. DIMMs operate at 4800 MHz at 1 DPC and 4400 MHz at 2 DPC.

Lenovo TruDDR5 memory uses the highest quality components that are sourced from Tier 1 DRAM suppliers and only memory that meets the strict requirements of Lenovo is selected. It is compatibility tested and tuned to maximize performance and reliability. From a service and support standpoint, Lenovo TruDDR5 memory automatically assumes the system warranty, and Lenovo provides service and support worldwide.

The following table lists the 4800 MHz memory options that are currently supported by the SR850 V3.

Table 8. 4800 MHz memory options

Part number	Feature code	Description	DRAM technology
9x4 RDIMMs - 4800 MHz			
4X77A77483	BNW5	ThinkSystem 32GB TruDDR5 4800MHz (1Rx4) 9x4 RDIMM	16Gb
4X77A77033	BKTN	ThinkSystem 64GB TruDDR5 4800MHz (2Rx4) 9x4 RDIMM	16Gb
10x4 RDIMMs - 4800 MHz			
4X77A77030	BNF6	ThinkSystem 32GB TruDDR5 4800MHz (1Rx4) 10x4 RDIMM	16Gb
4X77A77032	BNF9	ThinkSystem 64GB TruDDR5 4800MHz (2Rx4) 10x4 RDIMM	16Gb
4X77A87034	BZC2	ThinkSystem 96GB TruDDR5 4800MHz (2Rx4) RDIMM	24Gb
x8 RDIMMs - 4800 MHz			
4X77A77029	BKTL	ThinkSystem 16GB TruDDR5 4800MHz (1Rx8) RDIMM	16Gb
4X77A77031	BKTM	ThinkSystem 32GB TruDDR5 4800MHz (2Rx8) RDIMM	16Gb
3DS RDIMMs - 4800 MHz			
4X77A77034	BNFC	ThinkSystem 128GB TruDDR5 4800MHz (4Rx4) 3DS RDIMM v2	16Gb
CTO only	BY8F	ThinkSystem 128GB TruDDR5 4800MHz (4Rx4) 3DS RDIMM v1	16Gb
CTO only	BZPM	ThinkSystem 256GB TruDDR5 4800MHz (8Rx4) 3DS RDIMM v1	16Gb
4X77A77035	BNF8	ThinkSystem 256GB TruDDR5 4800MHz (8Rx4) 3DS RDIMM v2	16Gb

9x4 RDIMMs (also known as EC4 RDIMMs) are a new lower-cost DDR5 memory option supported in ThinkSystem V3 servers. 9x4 DIMMs offer the same performance as standard RDIMMs (known as 10x4 or EC8 modules), however they support lower fault-tolerance characteristics. Standard RDIMMs and 3DS RDIMMs support two 40-bit subchannels (that is, a total of 80 bits), whereas 9x4 RDIMMs support two 36-bit subchannels (a total of 72 bits). The extra bits in the subchannels allow standard RDIMMs and 3DS RDIMMs to support Single Device Data Correction (SDDC), however 9x4 RDIMMs do not support SDDC. Note, however, that all DDR5 DIMMs, including 9x4 RDIMMs, support Bounded Fault correction, which enables the server to correct most common types of DRAM failures.

For more information on DDR5 memory, see the Lenovo Press paper, *Introduction to DDR5 Memory*, available from <https://lenovopress.com/lp1618>.

The following rules apply when selecting the memory configuration:

- The SR850 V3 only supports quantities of 1, 2, 4, 6, 8, 12, or 16 DIMMs per processor; other quantities not supported
- The server supports three types of DIMMs: 9x4 RDIMMs, RDIMMs, and 3DS RDIMMs; UDIMMs and LRDIMMs are not supported
- Mixing of DIMM types is not supported (9x4 DIMMs with 10x4 RDIMMs, 9x4 DIMMs with 3DS RDIMMs, 10x4 RDIMMs with 3DS RDIMMs)
- Mixing of DRAM technology (16Gb and 24Gb) is not supported. See the column in the above table.
- Mixing x4 and x8 DIMMs is not supported
- Mixing of DIMM rank counts is supported. Follow the required installation order installing the DIMMs with the higher rank counts first.
- Mixing of DIMM capacities is supported, however only two different capacities are supported across all channels of the processor. Follow the required installation order installing the larger DIMMs first.
- Memory mirroring is not supported with 9x4 DIMMs
- The mixing of 128GB 3DS RDIMMs and 256GB 3DS RDIMMs is supported, however all DIMM slots must be populated evenly: 8x 128GB DIMMs and 8x 256GB DIMMs per processor
- Mixing DIMMs with 16Gb and 24Gb DRAM is not supported; this means the 96GB DIMM (feature BZC2) cannot be mixed with any other DIMM
- The 96GB DIMM, feature BZC2, requires a Platinum processor
- When the following memory DIMMs are installed, the number of backplanes that can be installed are limited due to thermal requirements:
  - 128GB 3DS RDIMMs: Server limited to 2 backplanes
  - 256GB 3DS RDIMMs: Server limited to 1 backplane

For best performance, consider the following:

- Ensure the memory installed is at least the same speed as the memory bus of the selected processor.
- Populate all 8 memory channels.

The following memory protection technologies are supported:

- ECC detection/correction
- Bounded Fault detection/correction
- SDDC (for x4-based memory DIMMs; look for "x4" in the DIMM description)
- ADDDC (for 10x4-based memory DIMMs, not supported with 9x4 DIMMs)
- Memory mirroring

See the Lenovo Press article "RAS Features of the Lenovo ThinkSystem Intel Servers" for more information about memory RAS features: <https://lenovopress.lenovo.com/lp1711-ras-features-of-the-lenovo-thinksystem-intel-servers>

If memory channel mirroring is used, then DIMMs must be installed in pairs (minimum of one pair per processor), and both DIMMs in the pair must be identical in type and size. 50% of the installed capacity is available to the operating system. Memory rank sparing is not supported.

## Internal storage

The SR850 V3 supports up to 24x 2.5-inch SAS/SATA or AnyBay drive bays. All 24x drive bays are hot-swap and all front-accessible. The server also supports internal M.2 drives (one or two, installed in an adapter), or rear-accessible hot-swap 7mm SSDs (installed in the place of two PCIe slots).

**Note:** M.2 and 7mm drive support is mutually exclusive, as they both use the same connectors.

In this section:

- [NVMe drive support](#)
- [Front drive bays](#)
- [Supported drive bay combinations](#)
- [M.2 drives](#)
- [7mm drives](#)
- [SED encryption key management with SKLM](#)

### NVMe drive support

The SR850 V3 supports up to 24x NVMe drives to maximize storage performance, each with a direct connection to the processors. All connections are made using onboard connectors; no NVMe retimer adapters are needed or supported. There is no oversubscription: each x4 drive has a full x4 (four PCIe Gen5 lanes) connection to the processor.

### Front drive bays

The front drive bay are configured using 8-bay backplanes. The two available backplanes are:

- 8-bay 2.5-inch SAS/SATA backplane
- 8-bay 2.5-inch AnyBay backplane

**Tip:** The SR850 V3 does not support 3.5-inch drive bays.

The locations of the backplanes is shown in the following figure.

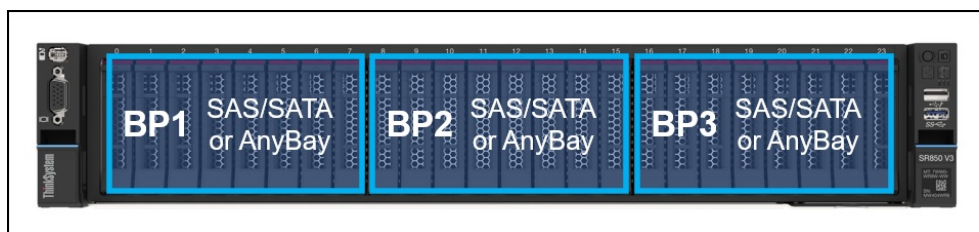

Figure 7. Backplanes

Ordering information for the backplanes is listed in the following table.

Table 9. Backplanes for front drive bays

Part number	Feature code	Description	Maximum supported
4XB7A86630	BT3B	ThinkSystem SR850 V3 8x 2.5" AnyBay Backplane Option Kit	3
4XB7A86629	BT3A	ThinkSystem SR850 V3/SR860 V3 8x 2.5" SAS/SATA Backplane Option Kit	3

Configuration rules:

- When any of the following adapters are installed, only 2 backplanes can be installed due to thermal requirements:
  - ThinkSystem Mellanox ConnectX-6 Dx 100GbE QSFP56 2-port PCIe Ethernet Adapter, 4XC7A08248
  - ThinkSystem Mellanox ConnectX-6 HDR/200GbE QSFP56 2-port PCIe 4 VPI Adapter, 4XC7A81089
  - ThinkSystem NVIDIA ConnectX-7 NDR200/HDR QSFP112 2-Port PCIe Gen5 x16 InfiniBand Adapter, 4XC7A81883
  - ThinkSystem NVIDIA ConnectX-7 NDR400 OSFP 1-Port PCIe Gen5 Adapter, 4XC7A80289
- When the following memory DIMMs are installed, the number of backplanes that can be installed are limited due to thermal limitations:
  - 128GB 3DS RDIMMs: Server limited to 2 backplanes
  - 256GB 3DS RDIMMs: Server limited to 1 backplane

### Field upgrades

For field upgrades, the backplane part numbers include the necessary cables for onboard NVMe connections as well as connections for both X350 and X40 RAID adapters/HBAs.

### Supported drive bay combinations

The following table shows the supported drive bay combinations - SAS/SATA or AnyBay drives. The table lists the backplanes required for each drive bay combination.

Some configurations require 4 processors be installed or are only supported when there are 2 processors. This is noted in the table.

Table 10. Supported drive bay combinations

Total drives	Total NVMe	CPU support	SAS/SATA backplane(s)	AnyBay backplane(s)		Backplanes
			SAS/SATA drives	SAS/SATA drives	NVMe drives	
8	0	2 or 4	8	0	0	1x SAS/SATA
8	4	2	0	4	4	1x AnyBay
8	8	4	0	0	8	1x AnyBay
16	0	2 or 4	16	0	0	2x SAS/SATA
16	8	2	0	8	8	2x AnyBay
16	8	4	8	0	8	1x SAS/SATA + 1x AnyBay
16	16	4	0	0	16	2x AnyBay
24	0	2 or 4	24	0	0	3x SAS/SATA
24	8	2	8	8	8	1x SAS/SATA + 2x AnyBay
24	8	4	16	0	8	2x SAS/SATA + 1x AnyBay
24	16	4	8	0	16	1x SAS/SATA + 2x AnyBay
24	24	4	0	0	24	3x AnyBay

## M.2 drives

The SR850 V3 supports one or two M.2 form-factor SATA or NVMe drives for use as an operating system boot solution or as additional storage. The M.2 drives install into an M.2 module which is mounted on the air baffle as shown in the [Components and connectors](#) section.

The supported M.2 modules are listed in the following table. For field upgrades see the [M.2 field upgrades](#) section below.

Table 11. M.2 modules

Part number	Feature code	Description	SATA drives	NVMe drives	RAID	Maximum supported
4Y37A09738	B5XJ	ThinkSystem M.2 SATA/NVMe 2-Bay Enablement Kit	Yes	Yes (x1 lane)	VROC	1
4Y37A79663	BM8X	ThinkSystem M.2 SATA/x4 NVMe 2-Bay Adapter	Yes	Yes (x4 lanes)	VROC	1
4Y37A09750	B8P9	ThinkSystem M.2 NVMe 2-Bay RAID Adapter	No	Yes (x1 lane)	Integrated	1

Configuration notes:

- M.2 and 7mm are mutually exclusive: they are not supported together in the same configuration
- RAID support is implemented as follows:
  - ThinkSystem M.2 SATA/NVMe 2-Bay Enablement Kit (4Y37A09738): VROC (SATA or NVMe); No additional adapter is required nor supported
  - ThinkSystem M.2 SATA/x4 NVMe 2-Bay Adapter (4Y37A79663): VROC (SATA or NVMe); No additional adapter is required nor supported
  - ThinkSystem M.2 NVMe 2-Bay RAID Adapter (4Y37A09750): RAID implemented using Marvell 88NR2241 NVMe RAID Controller (NVMe only)
- If RAID is enabled using VROC, select these feature codes:
  - VROC SATA support: On Board SATA Software RAID Mode for M.2 (feature BS7Q)
  - VROC NVMe support: Intel VROC (VMD NVMe RAID) Standard for M.2 (feature BS7M)

The ThinkSystem M.2 SATA/NVMe 2-Bay Enablement Kit has the following features:

- Supports one or two M.2 drives, either SATA or NVMe
- When two drives installed, they must be either both SATA or both NVMe
- Support 42mm, 60mm, 80mm and 110mm drive form factors (2242, 2260, 2280 and 22110)
- On the SR850 V3, RAID support is implemented using VROC SATA or VROC NVMe
- Either 6Gbps SATA or PCIe 3.0 x1 interface to the drives depending on the drives installed
- Supports monitoring and reporting of events and temperature through I2C
- Firmware update via Lenovo firmware update tools

The ThinkSystem M.2 SATA/x4 NVMe 2-Bay Adapter has the following features:

- Supports one or two M.2 drives, either SATA or NVMe
- When two drives installed, they must be either both SATA or both NVMe
- Support 42mm, 60mm, 80mm and 110mm drive form factors (2242, 2260, 2280 and 22110)
- On the SR850 V3, RAID support is implemented using VROC SATA or VROC NVMe
- Either 6Gbps SATA or PCIe 4.0 x4 interface to the drives depending on the drives installed
- Supports monitoring and reporting of events and temperature through I2C
- Firmware update via Lenovo firmware update tools

The ThinkSystem M.2 NVMe 2-Bay RAID Adapter (4Y37A09750) has the following features:

- Supports one or two NVMe M.2 drives
- Support 42mm, 60mm, 80mm and 110mm drive form factors (2242, 2260, 2280 and 22110)
- RAID support via an onboard Marvell 88NR2241 NVMe RAID Controller
- With 1 drive, supports single-drive RAID-0
- With 2 drives, supports 2-drive RAID-0, 2-drive RAID-1, or two single-drive RAID-0 arrays
- PCIe 3.0 x2 host interface; PCIe 3.0 x1 connection to each drive
- Management and configuration support via UEFI and OS-based tools
- Supports monitoring and reporting of events and temperature through I2C
- Firmware update via Lenovo firmware update tools

### M.2 field upgrades

For field upgrades, the SR850 V3 also requires an additional M.2 cable kit.

Ordering information is listed in the following table.

Table 12. M.2 cable kits

Part number	Feature code	Description
4X97A88013	BW25	ThinkSystem SR850 V3/SR860 V3 M.2 SATA/NVMe Cable Option Kit (Cable kit for 4Y37A09738 or 4Y37A09750)
4X97A88014	BW26	ThinkSystem SR850 V3/SR860 V3 M.2 SATA/x4 NVMe Cable Option Kit (Cable kit for 4Y37A79663)



## 7mm drives

The SR850 V3, when configured with full-height slots, supports two 7mm drives. 7mm drives are either both SATA or both NVMe. The drive bays are installed in place of both PCI slots 3 & 4 at the rear of the server, as shown in the following figure.

Support for 7mm drive bays is based on the riser cards selected for Riser 1 (feature code or option part number as listed in the [Riser ordering information](#) section. In addition to selecting the correct Riser 1 riser, you will also need to order the 7mm drive bays listed in the following table.

Table 13. 7mm drive bay ordering information

Part number	Feature code	Description	Max qty
4XB7A88714	BU0N	ThinkSystem SR850 V3/SR860 V3 7mm SATA/NVMe 2-Bay Rear Enablement Option Kit	1
4XB7A88715	B8P3	ThinkSystem SR850 V3/SR860 V3 7mm NVMe 2-Bay RAID Rear Enablement Option Kit	1

**M.2 and 7mm drive support:** The 7mm drives connect to the same ports on the system board as the M.2 module. As a result, 7mm and M.2 are mutually exclusive.

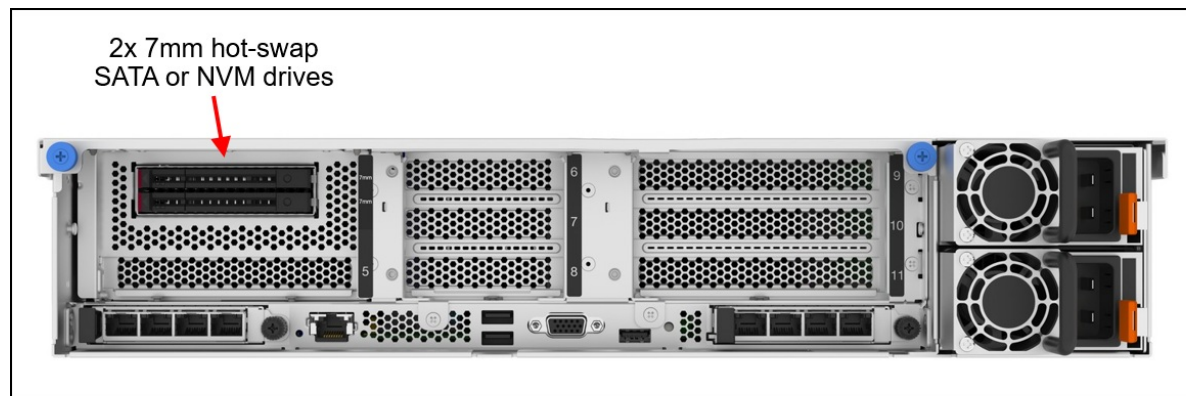

Figure 8. 7mm drive bays

The use of the 7mm rear drive bays has the following configuration rules:

- Only configurations with full-height (FH) slots support 7mm drive bays, base feature codes BT68 or BT69. The configuration with all low-profile slots (feature code BT67) does not support 7mm drive bays.
- M.2 and 7mm are mutually exclusive: they are not supported together in the same configuration
- For ThinkSystem 7mm SATA/NVMe 2-Bay Rear Enablement Kit v2 (feature BU0N):
  - The 7mm drive bays support either SATA drives or NVMe drives but not both at the same time.
  - RAID support is implemented using VROC SATA or VROC NVMe; No additional adapter is required nor supported.
  - If RAID is enabled using VROC, select these feature codes:
    - VROC SATA support: On Board SATA Software RAID Mode for 7mm (feature BS7U)
    - VROC NVMe support: Intel VROC (VMD NVMe RAID) Standard for 7mm (feature BS7R)
- For ThinkSystem 2U 7mm Drive Kit w/ NVMe RAID (feature B8P3)

- The adapter only supports NVMe drives
- RAID functionality is integrated into the M.2 adapter using a Marvell 88NR2241 NVMe RAID Controller

Field upgrades are enabled by replacing Riser 1 with a riser that enables support for the 7mm drives, as listed in the [Riser ordering information](#) section.

## SED encryption key management with SKLM

The server supports self-encrypting drives (SEDs) as listed in the [Internal drive options](#) section. To effectively manage a large deployment of these drives in Lenovo servers, IBM Security Key Lifecycle Manager (SKLM) offers a centralized key management solution. A Lenovo Feature on Demand (FoD) upgrade is used to enable this SKLM support in the management processor of the server.

The following table lists the part numbers and feature codes for the upgrades.

Table 14. FoD upgrades for SKLM support

Part number	Feature code	Description
Security Key Lifecycle Manager - FoD (United States, Canada, Asia Pacific, and Japan)		
00D9998	A5U1	SKLM for System x/ThinkSystem w/SEDs - FoD per Install with 1 year S&S
00D9999	AS6C	SKLM for System x/ThinkSystem w/SEDs - FoD per Install with 3 year S&S
Security Key Lifecycle Manager - FoD (Latin America, Europe, Middle East, and Africa)		
00FP648	A5U1	SKLM for System x/ThinkSystem w/SEDs - FoD per Install with 1 year S&S
00FP649	AS6C	SKLM for System x/ThinkSystem w/SEDs - FoD per Install with 3 year S&S

The IBM Security Key Lifecycle Manager software is available from Lenovo using the ordering information listed in the following table.

Table 15. IBM Security Key Lifecycle Manager licenses

Part number	Description
7S0A007FWW	IBM Security Key Lifecycle Manager Basic Edition Install License + SW Subscription & Support 12 Months
7S0A007HWW	IBM Security Key Lifecycle Manager For Raw Decimal Terabyte Storage Resource Value Unit License + SW Subscription & Support 12 Months
7S0A007KWW	IBM Security Key Lifecycle Manager For Raw Decimal Petabyte Storage Resource Value Unit License + SW Subscription & Support 12 Months
7S0A007MWW	IBM Security Key Lifecycle Manager For Usable Decimal Terabyte Storage Resource Value Unit License + SW Subscription & Support 12 Months
7S0A007PWW	IBM Security Key Lifecycle Manager For Usable Decimal Petabyte Storage Resource Value Unit License + SW Subscription & Support 12 Months

## Controllers for internal storage

The SR850 V3 supports offers a variety of controller options for internal drives:

- For 2.5-inch drives:
  - Onboard NVMe ports (RAID support provided using Intel VROC NVMe RAID)
  - RAID adapters and HBAs for SAS/SATA drives
- For 7mm drive bays in the rear of the server (see the [7mm drives](#) section)
  - SATA controller integrated into the 7mm drive bay enclosure
  - NVMe controller integrated into the 7mm drive bay enclosure (Intel VROC for RAID)

- For M.2 drives internal to the server (see [M.2 drives](#) section)
  - SATA controller integrated on the M.2 adapters
  - NVMe controller integrated on the M.2 adapters (Intel VROC for RAID)

The onboard NVMe support has the following features:

- Controller integrated into the Intel processor
- Supports up to 24 NVMe drives
- Each drive has PCIe Gen5 x4 host interface
- Supports JBOD - Intel and non-Intel NVMe SSDs
- Supports RAID-0, 1, 10 on Intel and non-Intel NVMe SSDs - Intel VROC Standard
- VROC Premium adds RAID-5 support on Intel and non-Intel NVMe SSDs

The following table lists the controllers and adapters used for the internal 2.5-inch drive bays of the SR850 V3 server.

**Legacy Option ROM support:** The server does not support legacy option boot ROM on PCIe adapters connected to CPU 3 or 4. See the [I/O expansion](#) section for details on which slots connect to each CPU. For option ROM support, install the adapters in slots connected to CPU 1 or 2, or use UEFI boot mode on those adapters instead.

Table 16. Controllers for internal storage

Part number	Feature code	Description	Maximum supported
<b>Onboard NVMe - Intel VROC NVMe RAID</b>			
None	BR9B	Intel VROC (VMD NVMe RAID) Standard (supports RAID 0, 1, 10 for all brands of drives)	1
4L47A39164	B96G	Intel VROC (VMD NVMe RAID) Premium (license upgrade - to enable RAID-5 support)	1
<b>SAS HBA - PCIe 3.0</b>			
4Y37A72480	BJHH	ThinkSystem 4350-8i SAS/SATA 12Gb HBA	1
4Y37A72481	BJHJ	ThinkSystem 4350-16i SAS/SATA 12Gb HBA	1
<b>SAS HBA - PCIe 4.0</b>			
4Y37A78601	BM51	ThinkSystem 440-8i SAS/SATA PCIe Gen4 12Gb HBA	1
4Y37A78602	BM50	ThinkSystem 440-16i SAS/SATA PCIe Gen4 12Gb HBA	1
<b>RAID Adapter - PCIe 3.0</b>			
4Y37A72482	BJHK	ThinkSystem RAID 5350-8i PCIe 12Gb Adapter	1
4Y37A72483	BJHL	ThinkSystem RAID 9350-8i 2GB Flash PCIe 12Gb Adapter	1
4Y37A72485	BJHN	ThinkSystem RAID 9350-16i 4GB Flash PCIe 12Gb Adapter	1
<b>RAID Adapter - PCIe 4.0</b>			
4Y37A78834	BMFT	ThinkSystem RAID 540-8i PCIe Gen4 12Gb Adapter	1
4Y37A78835	BNAX	ThinkSystem RAID 540-16i PCIe Gen4 12Gb Adapter	1
4Y37A09728†	B8NY	ThinkSystem RAID 940-8i 4GB Flash PCIe Gen4 12Gb Adapter	1
4Y37A78600†	BM35	ThinkSystem RAID 940-16i 4GB Flash PCIe Gen4 12Gb Adapter	1
4Y37A09730†	B8NZ	ThinkSystem RAID 940-16i 8GB Flash PCIe Gen4 12Gb Adapter	1
4Y37A09733	B8P8	ThinkSystem RAID 940-32i 8GB Flash PCIe Gen4 12Gb Adapter	1
<b>NVMe using Tri-Mode</b>			
4Y37A09728†	BGM1	ThinkSystem RAID 940-8i 4GB Flash PCIe Gen4 12Gb Adapter for U.3	1

Part number	Feature code	Description	Maximum supported
4Y37A78600†	BM36	ThinkSystem RAID 940-16i 4GB Flash PCIe Gen4 12Gb Adapter for U.3	1
4Y37A09730†	BDY4	ThinkSystem RAID 940-16i 8GB Flash PCIe Gen4 12Gb Adapter for U.3	1

† Adapter also supports PCIe 4.0 x1 connectivity to NVMe drives (requires NVMe drives with U.3 interface)

Configuration notes:

- **Supercap support limits the number of RAID adapters installable** : RAID 9350 and RAID 940 adapters include and require a power module (supercap) to power the flash memory. The SR850 V3 supports up to 2 supercaps, installed in dedicated holders on the air baffle as shown in the [Components and connectors](#) section. The number of supercaps supported also determines the maximum number of internal + external RAID 9xx adapters that can be installed in the server.
- **Field upgrades**: The RAID 9xx adapter part numbers include both the supercap and the supercap cable.
- **E810 Ethernet and X350 RAID/HBAs**: The use of both an Intel E810 network adapter and an X350 HBA/RAID adapter (9350, 5350 and 4350) is currently not supported in ThinkSystem servers. For details see [Support Tip HT513226](#). Planned support for this combination of adapters is 2Q/2024.

The RAID 940-8i and RAID 940-16i adapters also support NVMe through a feature named Tri-Mode support (or Trimode support). This feature enables the use of NVMe U.3 drives at the same time as SAS and SATA drives. Tri-Mode requires an AnyBay backplane. Cabling of the controller to the backplanes is the same as with SAS/SATA drives, and the NVMe drives are connected via a PCIe x1 link to the controller.

NVMe drives connected using Tri-Mode support provide better performance than SAS or SATA drives: A SATA SSD has a data rate of 6Gbps, a SAS SSD has a data rate of 12Gbps, whereas an NVMe U.3 Gen 4 SSD with a PCIe x1 link will have a data rate of 16Gbps. NVMe drives typically also have lower latency and higher IOPS compared to SAS and SATA drives. Tri-Mode is supported with U.3 NVMe drives in either 2.5-inch and 3.5-inch form factor and requires an AnyBay backplane.

**Tri-Mode requires U.3 drives**: Only NVMe drives with a U.3 interface are supported. U.2 drives are not supported. See the [Internal drive options](#) section for the U.3 drives supported by the server.

## Intel VROC onboard RAID

Intel VROC (Virtual RAID on CPU) is a feature of the Intel processor that enables RAID support.

There are two separate functions of VROC in the SR850 V3:

- Intel VROC SATA RAID, formerly known as Intel RSTe
- Intel VROC NVMe RAID

VROC SATA RAID (RSTe) is available and supported with all SATA drives. It offers a 6 Gb/s connection to each drive and on the SR850 V3 implements RAID levels 0, 1, 5, and 10. RAID 1 is limited to 2 drives per array, and RAID 10 is limited to 4 drives per array. Hot-spare functionality is also supported.

VROC NVMe RAID offers RAID support for any NVMe drives directly connected to the ports on the server's system board or via adapters such as NVMe retimers or NVMe switch adapters. On the SR850 V3, RAID levels implemented are based on the VROC feature selected as indicated in the following table. RAID 1 is limited to 2 drives per array, and RAID 10 is limited to 4 drives per array. Hot-spare functionality is also supported.

**Performance tip**: For best performance with VROC NVMe RAID, the drives in an array should all be connected to the same processor. Spanning processors is possible however performance will be unpredictable and should be evaluated based on your workload.

The SR850 V3 supports the VROC NVMe RAID offerings listed in the following table.

**Tip:** These feature codes and part numbers are only for VROC RAID using NVMe drives, not SATA drives

Table 17. Intel VROC NVMe RAID ordering information and feature support

Part number	Feature code	Description	Intel NVMe SSDs	Non-Intel NVMe SSDs	RAID 0	RAID 1	RAID 10	RAID 5
4L47A83669	BR9B	Intel VROC (VMD NVMe RAID) Standard	Yes	Yes	Yes	Yes	Yes	No
4L47A39164	B96G	Intel VROC (VMD NVMe RAID) Premium	Yes	Yes	Yes	Yes	Yes	Yes

Configuration notes:

- If a feature code is ordered in a CTO build, the VROC functionality is enabled in the factory. For field upgrades, order a part number and it will be fulfilled as a Feature on Demand (FoD) license which can then be activated via the XCC management processor user interface.

**Virtualization support:** Virtualization support for Intel VROC is as follows:

- **VROC SATA RAID (RSTe):** VROC SATA RAID is not supported by virtualization hypervisors such as ESXi, KVM, Xen, and Hyper-V. Virtualization is only supported on the onboard SATA ports in AHCI (non-RAID) mode.
- **VROC (VMD) NVMe RAID :** VROC (VMD) NVMe RAID is supported by ESXi, KVM, Xen, and Hyper-V. ESXi support is limited to RAID 1 only; other RAID levels are not supported. Windows and Linux OSes support VROC RAID NVMe, both for host boot functions and for guest OS function, and RAID-0, 1, 5, and 10 are supported. On ESXi, VROC is supported with both boot and data drives.

For specifications about the RAID adapters and HBAs supported by the SR850 V3, see the ThinkSystem RAID Adapter and HBA Comparison, available from:

<https://lenovopress.com/lp1288-lenovo-thinksystem-raid-adapter-and-hba-reference#sr850-v3-support=SR850%2520V3>

For details about these adapters, see the relevant product guide:

- SAS HBAs: <https://lenovopress.com/servers/options/hba>
- RAID adapters: <https://lenovopress.com/servers/options/raid>

## Internal drive options

The following tables list the drive options for internal storage of the server.

2.5-inch hot-swap drives:

- [2.5-inch hot-swap 12 Gb SAS HDDs](#)
- [2.5-inch hot-swap 24 Gb SAS SSDs](#)
- [2.5-inch hot-swap 12 Gb SAS SSDs](#)
- [2.5-inch hot-swap 6 Gb SATA SSDs](#)
- [2.5-inch hot-swap PCIe 5.0 NVMe SSDs](#)
- [2.5-inch hot-swap PCIe 4.0 NVMe SSDs](#)

2.5-inch 7mm hot-swap drives:

- [7mm 2.5-inch hot-swap 6 Gb SATA SSDs](#)
- [7mm 2.5-inch hot-swap PCIe 4.0 NVMe SSDs](#)

M.2 drives:

- [M.2 SATA drives](#)
- [M.2 PCIe 4.0 NVMe drives](#)

**M.2 drive support:** The use of M.2 drives requires an additional adapter as described in the [M.2 drives](#) subsection.

**SED support:** The tables include a column to indicate which drives support SED encryption. The encryption functionality can be disabled if needed. Note: Not all SED-enabled drives have "SED" in the description.

Table 18. 2.5-inch hot-swap 12 Gb SAS HDDs

Part number	Feature code	Description	SED support	Max Qty
<b>2.5-inch hot-swap HDDs - 12 Gb SAS 15K</b>				
7XB7A00021	AULV	ThinkSystem 2.5" 300GB 15K SAS 12Gb Hot Swap 512n HDD	No	24
7XB7A00022	AULW	ThinkSystem 2.5" 600GB 15K SAS 12Gb Hot Swap 512n HDD	No	24
7XB7A00023	AULX	ThinkSystem 2.5" 900GB 15K SAS 12Gb Hot Swap 512e HDD	No	24
<b>2.5-inch hot-swap HDDs - 12 Gb SAS 10K</b>				
7XB7A00025	AULZ	ThinkSystem 2.5" 600GB 10K SAS 12Gb Hot Swap 512n HDD	No	24
7XB7A00027	AUM1	ThinkSystem 2.5" 1.2TB 10K SAS 12Gb Hot Swap 512n HDD	No	24
7XB7A00028	AUM2	ThinkSystem 2.5" 1.8TB 10K SAS 12Gb Hot Swap 512e HDD	No	24
4XB7A83970	BRG7	ThinkSystem 2.5" 2.4TB 10K SAS 12Gb Hot Swap 512e HDD v2	No	24
<b>2.5-inch hot-swap SED HDDs - 12 Gb SAS 10K</b>				
7XB7A00031	AUM5	ThinkSystem 2.5" 600GB 10K SAS 12Gb Hot Swap 512n HDD SED	Support	24
7XB7A00033	B0YX	ThinkSystem 2.5" 1.2TB 10K SAS 12Gb Hot Swap 512n HDD SED	Support	24
4XB7A84038	BRG8	ThinkSystem 2.5" 2.4TB 10K SAS 12Gb Hot Swap 512e HDD FIPS v2	Support	24

Table 19. 2.5-inch hot-swap 24 Gb SAS SSDs

Part number	Feature code	Description	SED support	Max Qty
<b>2.5-inch hot-swap SSDs - 24 Gb SAS - Mixed Use/Mainstream (3-5 DWPD)</b>				
4XB7A80340	BNW8	ThinkSystem 2.5" PM1655 800GB Mixed Use SAS 24Gb HS SSD	Support	24
4XB7A80341	BNW9	ThinkSystem 2.5" PM1655 1.6TB Mixed Use SAS 24Gb HS SSD	Support	24
4XB7A80342	BNW6	ThinkSystem 2.5" PM1655 3.2TB Mixed Use SAS 24Gb HS SSD	Support	24
4XB7A80343	BP3K	ThinkSystem 2.5" PM1655 6.4TB Mixed Use SAS 24Gb HS SSD	Support	24
<b>2.5-inch hot-swap SSDs - 24 Gb SAS - Read Intensive/Entry/Capacity (&lt;3 DWPD)</b>				
4XB7A80318	BNWC	ThinkSystem 2.5" PM1653 960GB Read Intensive SAS 24Gb HS SSD	Support	24
4XB7A80319	BNWE	ThinkSystem 2.5" PM1653 1.92TB Read Intensive SAS 24Gb HS SSD	Support	24
4XB7A80320	BNWF	ThinkSystem 2.5" PM1653 3.84TB Read Intensive SAS 24Gb HS SSD	Support	24
4XB7A80321	BP3E	ThinkSystem 2.5" PM1653 7.68TB Read Intensive SAS 24Gb HS SSD	Support	24
4XB7A80322	BP3J	ThinkSystem 2.5" PM1653 15.36TB Read Intensive SAS 24Gb HS SSD	Support	24
4XB7A80323	BP3D	ThinkSystem 2.5" PM1653 30.72TB Read Intensive SAS 24Gb HS SSD	Support	24

Table 20. 2.5-inch hot-swap 12 Gb SAS SSDs

Part number	Feature code	Description	SED support	Max Qty
<b>2.5-inch hot-swap SSDs - 12 Gb SAS - Write Intensive/Performance (10+ DWPD)</b>				
4XB7A83214	BR10	ThinkSystem 2.5" Nytro 3750 400GB Write Intensive SAS 12Gb HS SSD	Support	24
4XB7A83215	BR0Z	ThinkSystem 2.5" Nytro 3750 800GB Write Intensive SAS 12Gb HS SSD	Support	24
4XB7A83216	BR0Y	ThinkSystem 2.5" Nytro 3750 1.6TB Write Intensive SAS 12Gb HS SSD	Support	24
4XB7A83217	BR0X	ThinkSystem 2.5" Nytro 3750 3.2TB Write Intensive SAS 12Gb HS SSD	Support	24

Table 21. 2.5-inch hot-swap 6 Gb SATA SSDs

Part number	Feature code	Description	SED support	Max Qty
<b>2.5-inch hot-swap SSDs - 6 Gb SATA - Mixed Use/Mainstream (3-5 DWPD)</b>				
4XB7A82289	BQ21	ThinkSystem 2.5" 5400 MAX 480GB Mixed Use SATA 6Gb HS SSD	Support	24
4XB7A82290	BQ24	ThinkSystem 2.5" 5400 MAX 960GB Mixed Use SATA 6Gb HS SSD	Support	24
4XB7A82291	BQ22	ThinkSystem 2.5" 5400 MAX 1.92TB Mixed Use SATA 6Gb HS SSD	Support	24
4XB7A82292	BQ23	ThinkSystem 2.5" 5400 MAX 3.84TB Mixed Use SATA 6Gb HS SSD	Support	24
4XB7A17125	BA7Q	ThinkSystem 2.5" S4620 480GB Mixed Use SATA 6Gb HS SSD	No	24
4XB7A17126	BA4T	ThinkSystem 2.5" S4620 960GB Mixed Use SATA 6Gb HS SSD	No	24
4XB7A17127	BA4U	ThinkSystem 2.5" S4620 1.92TB Mixed Use SATA 6Gb HS SSD	No	24
4XB7A17128	BK7L	ThinkSystem 2.5" S4620 3.84TB Mixed Use SATA 6Gb HS SSD	No	24
<b>2.5-inch hot-swap SSDs - 6 Gb SATA - Read Intensive/Entry (&lt;3 DWPD)</b>				
4XB7A82258	BQ1Q	ThinkSystem 2.5" 5400 PRO 240GB Read Intensive SATA 6Gb HS SSD	Support	24
4XB7A82259	BQ1P	ThinkSystem 2.5" 5400 PRO 480GB Read Intensive SATA 6Gb HS SSD	Support	24
4XB7A82260	BQ1R	ThinkSystem 2.5" 5400 PRO 960GB Read Intensive SATA 6Gb HS SSD	Support	24
4XB7A82261	BQ1X	ThinkSystem 2.5" 5400 PRO 1.92TB Read Intensive SATA 6Gb HS SSD	Support	24
4XB7A82262	BQ1S	ThinkSystem 2.5" 5400 PRO 3.84TB Read Intensive SATA 6Gb HS SSD	Support	24
4XB7A82263	BQ1T	ThinkSystem 2.5" 5400 PRO 7.68TB Read Intensive SATA 6Gb HS SSD	Support	24
4XB7A17072	B99D	ThinkSystem 2.5" S4520 240GB Read Intensive SATA 6Gb HS SSD	No	24
4XB7A17101	BA7G	ThinkSystem 2.5" S4520 480GB Read Intensive SATA 6Gb HS SSD	No	24
4XB7A17102	BA7H	ThinkSystem 2.5" S4520 960GB Read Intensive SATA 6Gb HS SSD	No	24
4XB7A17103	BA7J	ThinkSystem 2.5" S4520 1.92TB Read Intensive SATA 6Gb HS SSD	No	24
4XB7A17104	BK77	ThinkSystem 2.5" S4520 3.84TB Read Intensive SATA 6Gb HS SSD	No	24
4XB7A17105	BK78	ThinkSystem 2.5" S4520 7.68TB Read Intensive SATA 6Gb HS SSD	No	24

Table 22. 2.5-inch hot-swap PCIe 5.0 NVMe SSDs

Part number	Feature code	Description	SED support	Max Qty
<b>2.5-inch SSDs - U.2 PCIe 5.0 NVMe - Read Intensive/Entry (&lt;3 DWPD)</b>				
4XB7A82366	BTPZ	ThinkSystem 2.5" U.3 PM1743 1.92TB Read Intensive NVMe PCIe 5.0 x4 HS SSD	Support	24
4XB7A82367	BTQ0	ThinkSystem 2.5" U.3 PM1743 3.84TB Read Intensive NVMe PCIe 5.0 x4 HS SSD	Support	24
4XB7A82368	BTQ1	ThinkSystem 2.5" U.3 PM1743 7.68TB Read Intensive NVMe PCIe 5.0 x4 HS SSD	Support	24
4XB7A82369	BTQ2	ThinkSystem 2.5" U.3 PM1743 15.36TB Read Intensive NVMe PCIe 5.0 x4 HS SSD	Support	24



Table 23. 2.5-inch hot-swap PCIe 4.0 NVMe SSDs

Part number	Feature code	Description	SED support	Max Qty
<b>2.5-inch SSDs - U.2 PCIe 4.0 NVMe - Write Intensive/Performance (10+ DWPD)</b>				
4XB7A17158	BKKY	ThinkSystem 2.5" U.2 P5800X 400GB Write Intensive NVMe PCIe 4.0 x4 HS SSD	No	24
4XB7A17159	BKKZ	ThinkSystem 2.5" U.2 P5800X 800GB Write Intensive NVMe PCIe 4.0 x4 HS SSD	No	24
4XB7A17160	BMM8	ThinkSystem 2.5" U.2 P5800X 1.6TB Write Intensive NVMe PCIe 4.0 x4 HS SSD	No	24
<b>2.5-inch SSDs - U.2 PCIe 4.0 NVMe - Mixed Use/Mainstream (3-5 DWPD)</b>				
4XB7A17129	BNEG	ThinkSystem 2.5" U.2 P5620 1.6TB Mixed Use NVMe PCIe 4.0 x4 HS SSD	Support	24
4XB7A17130	BNEH	ThinkSystem 2.5" U.2 P5620 3.2TB Mixed Use NVMe PCIe 4.0 x4 HS SSD	Support	24
4XB7A17133	BNEZ	ThinkSystem 2.5" U.2 P5620 6.4TB Mixed Use NVMe PCIe 4.0 x4 HS SSD	Support	24
4XB7A17136	BA4V	ThinkSystem 2.5" U.2 P5620 12.8TB Mixed Use NVMe PCIe 4.0 x4 HS SSD	Support	24
<b>2.5-inch SSDs - U.3 PCIe 4.0 NVMe - Mixed Use/Mainstream (3-5 DWPD)</b>				
4XB7A13967	BNEJ	ThinkSystem 2.5" U.3 7450 MAX 1.6TB Mixed Use NVMe PCIe 4.0 x4 HS SSD	Support	24
4XB7A13970	BNEY	ThinkSystem 2.5" U.3 7450 MAX 3.2TB Mixed Use NVMe PCIe 4.0 x4 HS SSD	Support	24
4XB7A13971	BNEL	ThinkSystem 2.5" U.3 7450 MAX 6.4TB Mixed Use NVMe PCIe 4.0 x4 HS SSD	Support	24
<b>2.5-inch SSDs - U.2 PCIe 4.0 NVMe - Read Intensive/Entry (&lt;3 DWPD)</b>				
4XB7A13941	BMGD	ThinkSystem 2.5" U.2 P5520 1.92TB Read Intensive NVMe PCIe 4.0 x4 HS SSD	Support	24
4XB7A13942	BMGE	ThinkSystem 2.5" U.2 P5520 3.84TB Read Intensive NVMe PCIe 4.0 x4 HS SSD	Support	24
4XB7A13943	BNEF	ThinkSystem 2.5" U.2 P5520 7.68TB Read Intensive NVMe PCIe 4.0 x4 HS SSD	Support	24
4XB7A13631	BNEQ	ThinkSystem 2.5" U.2 P5520 15.36TB Read Intensive NVMe PCIe 4.0 x4 HS SSD	Support	24
<b>2.5-inch SSDs - U.3 PCIe 4.0 NVMe - Read Intensive/Entry (&lt;3 DWPD)</b>				
4XB7A79646	BNF3	ThinkSystem 2.5" U.3 7450 PRO 960GB Read Intensive NVMe PCIe 4.0 x4 HS SSD	Support	24
4XB7A79647	BNF2	ThinkSystem 2.5" U.3 7450 PRO 1.92TB Read Intensive NVMe PCIe 4.0 x4 HS SSD	Support	24
4XB7A79648	BNF5	ThinkSystem 2.5" U.3 7450 PRO 3.84TB Read Intensive NVMe PCIe 4.0 x4 HS SSD	Support	24
4XB7A79649	BNF4	ThinkSystem 2.5" U.3 7450 PRO 7.68TB Read Intensive NVMe PCIe 4.0 x4 HS SSD	Support	24

Table 24. 7mm 2.5-inch hot-swap 6 Gb SATA SSDs

Part number	Feature code	Description	SED support	Max Qty
<b>7mm 2.5-inch hot-swap SSDs - 6 Gb SATA - Read Intensive/Entry (&lt;3 DWPD)</b>				
4XB7A82264	BQ1U	ThinkSystem 7mm 5400 PRO 240GB Read Intensive SATA 6Gb HS SSD	Support	2
4XB7A82265	BQ1V	ThinkSystem 7mm 5400 PRO 480GB Read Intensive SATA 6Gb HS SSD	Support	2
4XB7A82266	BQ1W	ThinkSystem 7mm 5400 PRO 960GB Read Intensive SATA 6Gb HS SSD	Support	2
4XB7A17106	BK79	ThinkSystem 7mm S4520 240GB Read Intensive SATA 6Gb HS SSD	No	2
4XB7A17107	BK7A	ThinkSystem 7mm S4520 480GB Read Intensive SATA 6Gb HS SSD	No	2
4XB7A17108	BK7B	ThinkSystem 7mm S4520 960GB Read Intensive SATA 6Gb HS SSD	No	2

Table 25. 7mm 2.5-inch hot-swap PCIe 4.0 NVMe SSDs

Part number	Feature code	Description	SED support	Max Qty
<b>7mm 2.5-inch hot-swap SSDs - PCIe 4.0 NVMe - Read Intensive/Entry (&lt;3 DWPD)</b>				
4XB7A82853	BPZ4	ThinkSystem 7mm U.3 7450 PRO 960GB Read Intensive NVMe PCIe 4.0 x4 HS SSD	Support	2
4XB7A82855	BPZ5	ThinkSystem 7mm U.3 7450 PRO 1.92TB Read Intensive NVMe PCIe 4.0 x4 HS SSD	Support	2
4XB7A82856	BPZ6	ThinkSystem 7mm U.3 7450 PRO 3.84TB Read Intensive NVMe PCIe 4.0 x4 HS SSD	Support	2

Table 26. M.2 SATA drives

Part number	Feature code	Description	SED support	Max Qty
<b>M.2 SSDs - 6 Gb SATA - Read Intensive/Entry (&lt;3 DWPD)</b>				
4XB7A89422	BYF7	ThinkSystem M.2 ER3 240GB Read Intensive SATA 6Gb NHS SSD	Support	2
4XB7A90049	BYF8	ThinkSystem M.2 ER3 480GB Read Intensive SATA 6Gb NHS SSD	Support	2
4XB7A90230	BYF9	ThinkSystem M.2 ER3 960GB Read Intensive SATA 6Gb NHS SSD	Support	2
4XB7A82286	BQ1Z	ThinkSystem M.2 5400 PRO 240GB Read Intensive SATA 6Gb NHS SSD	Support	2
4XB7A82287	BQ1Y	ThinkSystem M.2 5400 PRO 480GB Read Intensive SATA 6Gb NHS SSD	Support	2
4XB7A82288	BQ20	ThinkSystem M.2 5400 PRO 960GB Read Intensive SATA 6Gb NHS SSD	Support	2
7N47A00130	AUUV	ThinkSystem M.2 128GB SATA 6Gbps Non-Hot Swap SSD	No	2

Table 27. M.2 PCIe 4.0 NVMe drives

Part number	Feature code	Description	SED support	Max Qty
<b>M.2 SSDs - PCIe 4.0 NVMe - Read Intensive/Entry (&lt;3 DWPD)</b>				
4XB7A90102	BXMH	ThinkSystem M.2 PM9A3 960GB Read Intensive NVMe PCIe 4.0 x4 NHS SSD	Support	2
4XB7A82636	BS2P	ThinkSystem M.2 7450 PRO 480GB Read Intensive NVMe PCIe 4.0 x4 NHS SSD	Support	2
4XB7A13999	BKSR	ThinkSystem M.2 7450 PRO 960GB Read Intensive NVMe PCIe 4.0 x4 NHS SSD	Support	2

## USB memory key

For general portable storage needs, the server also supports the USB memory key option that is listed in the following table.

Table 28. USB memory key

Part number	Feature	Description
4X77A77065	BNWN	ThinkSystem USB 32GB USB 3.0 Flash Drive

## Internal backup units

The server does not support any internal backup units.

## Optical drives

The server does not support an internal optical drive.

An external USB optical drive is available, listed in the following table.

Table 29. External optical drive

Part number	Feature code	Description
7XA7A05926	AVV8	ThinkSystem External USB DVD RW Optical Disk Drive

## I/O expansion

The SR850 V3 supports up to 14 PCIe slots: up to 12x regular PCIe slots – either Gen4 or Gen5 – plus two OCP 3.0 slots with Gen5 interfaces.

**DW GPU support and full-length adapter support** : For double-wide GPU or full-length adapter support, you *must* select base BT69. The standard bases (BT67 and BT68) only support half-length and low-profile adapters and cannot be upgraded in the field to support full-length adapters or GPUs. See the [Models](#) section for more information about base feature codes.

Topics in this section:

- [Riser & slot support](#)
- [Riser ordering information](#)
- [Riser supported combinations - 3 risers](#)
- [Riser supported combinations - 4 risers](#)

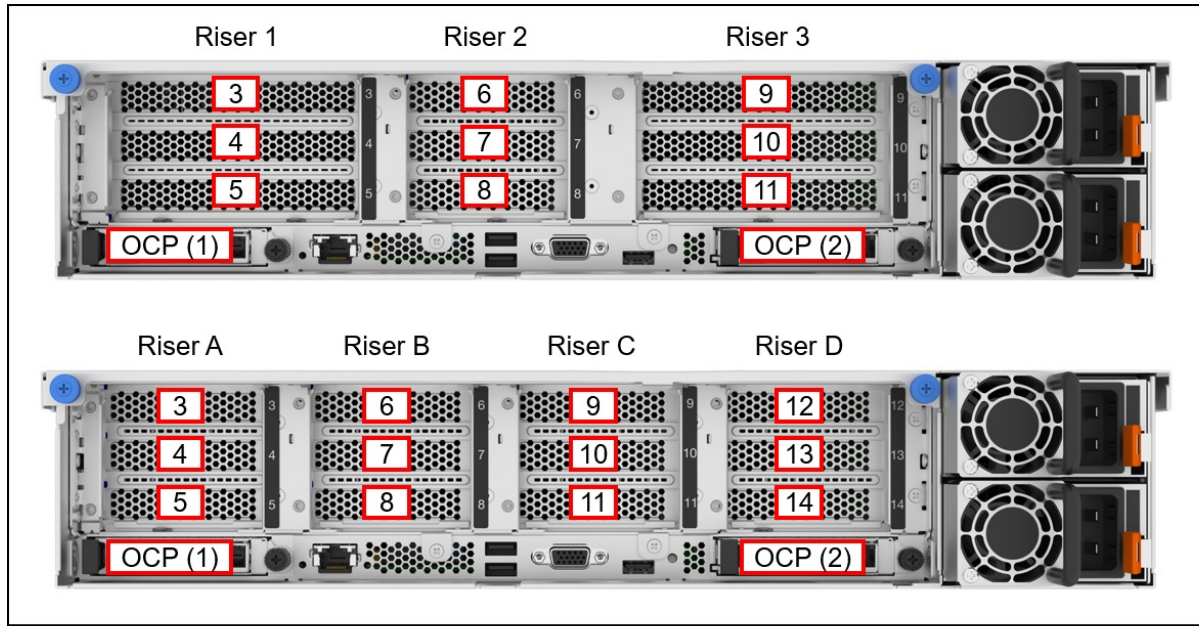

Figure 9. Slots in the SR850 V3

### Riser & slot support

The SR850 V3 server supports Gen4-only or Gen5+Gen4 slot configurations to suit the needs of installed applications.

#### 12x Low Profile + 2x OCP slots (4 risers)

For applications that require as many slots as possible, the SR850 V3 supports a configuration with 12x Low Profile slots plus 2x OCP slots.

PCIe Gen4 or a mix of Gen5/Gen4 is supported:

- 12x Gen4 LP + 2x OCP Gen5 (using Gen4 risers)
- 8x Gen5 + 4x Gen4 LP + 2x OCP Gen5 (using Gen5 risers)

These configurations use Base feature code BT67 as described in the [Models](#) section. These configurations also offer:

- Optionally serial port, installed in place of slot 11

The following figure shows the two 12x Low Profile configurations. Blue slots are Gen4 and green slots are Gen5. The processor that each slot is connected to is also shown in the figure as P1, P2, P3 or P4.

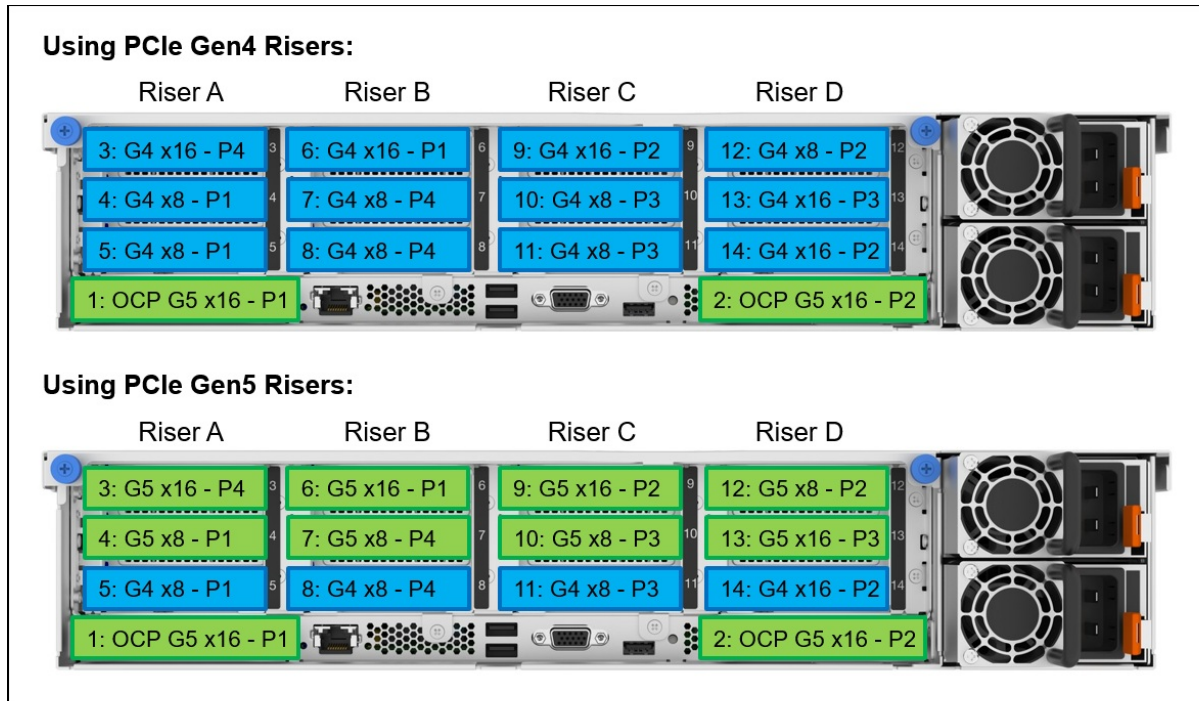

Figure 10. SR850 V3 with 12x Low Profile slots + 2x OCP slots (blue slots are Gen4 and green slots are Gen5)

### Up to 6x Full Height slots + 3x Low Profile slots + 2x OCP slots (3 risers)

For applications that require full-height half-length (FHHL) slots or full-height full-length (FHFL) slots (including double-wide GPUs), the SR850 V3 supports a configuration with 6x Full Height slots + 3x Low Profile slots plus 2x OCP slots.

PCIe Gen4 or a mix of Gen5/Gen4 is supported:

- 6x Gen4 FH + 3x Gen4 LP + 2x OCP Gen5 (using Gen4 risers)
- 6x Gen5 + 1x Gen4 + 2x OCP Gen5 (using Gen5 risers)

The full-height slots are either full-length or half-length, depending on the Base feature code selected, as described in the [Models](#) section:

- Base feature BT68: half-length (FHHL) slots
- Base feature BT69: full-length (FHFL) slots including double-wide GPUs

These configurations also offer:

- Optionally serial port, installed in place of slot 11
- Optional 7mm hot-swap drive bays, installed in place of slots 3 & 4

**GPUs with 7mm drives:** The 7mm drives, if configured, occupy the same space as one of the double-wide GPUs. This means that with 7mm drives, only one DW GPU can be installed.

**Upgrading HL slots to FL not supported:** It is not supported to upgrade FHHL slots (base BT68) to FHFL slots (base BT69).

The following figure shows the two 6x FH slots + 3x LP slots configurations. Blue slots are Gen4 and green slots are Gen5. The red shading indicates where the double-wide GPUs can be installed. The processor that each slot is connected to is also shown in the figure as P1, P2, P3 or P4.

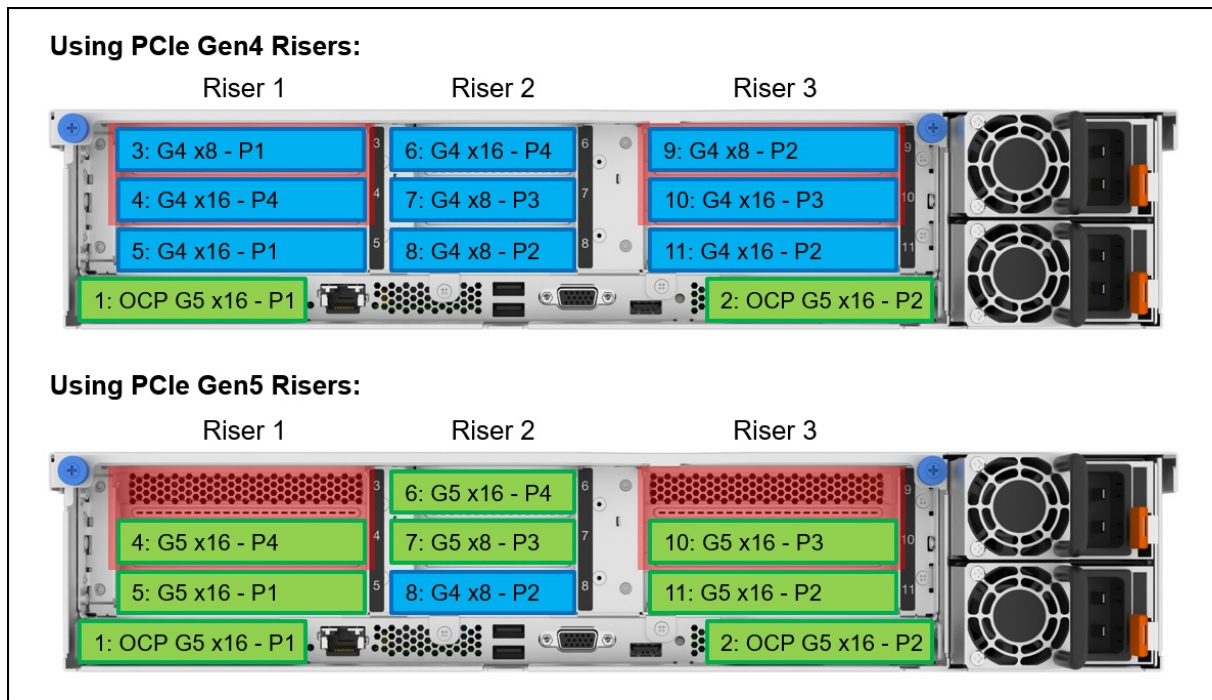

Figure 11. SR850 V3 with 6x Full Height slots + 3x Low Profile slots (blue slots are Gen4 and green slots are Gen5)

### Riser ordering information

The riser cards supported are listed in the following table. The table also lists the total slots and what type of slots each riser card includes. All of the x8 slots have a physical x16 connector.

**Risers with 7mm drive cages:** As listed in the table, some risers include support for two 7mm hot-swap drive bays installed in Riser 1. The part numbers and feature codes include the cages and cables needed for the 7mm drive bays, however the 7mm drive bays themselves (backplanes) will need to be ordered as well. See the [7mm drives](#) section for details.

**Serial port is CTO only:** The serial port is only available CTO by configuring one of the LP risers for Riser 2 or Riser C. The serial port cannot be added a field upgrade.

Table 30. Riser part numbers (Blue = Gen4, green = Gen5)

Part number	Feature code	Description	Base support			Slots					7mm drives	Serial port
			LP base BT67	FH base BT68	GPU base BT69	Total slots	G4 x8	G4 x16	G5 x8	G5 x16		
<b>FHFL risers for Riser 1 and 3</b>												
4XC7A86618	BT6W	ThinkSystem SR850 V3 x8/x16/x16 PCIe G4 Riser 1/3 FHFL Option Kit	No	No	Yes	3	1	2	0	0	No	No
4XC7A86619	BT70	ThinkSystem SR850 V3 x16/x16 PCIe G5 Riser 1/3 FHFL Option Kit	No	No	Yes	2	0	0	0	2	No	No
<b>FHHL risers with 7mm drive cages for Riser 1 (include 2x 7mm drive cages; order drive bays separately - See the 7mm drives section)</b>												
4XC7A87073	BT6Z	ThinkSystem SR850 V3 7mm/x16 PCIe G4 Riser 1 FHHL Option Kit	No	Yes	No	1	0	1	0	0	Yes	No
4XC7A87074	BT73	ThinkSystem SR850 V3 7mm/x16 PCIe G5 Riser 1 FHHL Option Kit	No	Yes	No	1	0	0	0	1	Yes	No
<b>LP risers for Riser 2 and Riser A, B, C</b>												
4XC7A86621	BT6X	ThinkSystem SR850 V3 x16/x8/x8 PCIe G4 Riser 2/A/B/C HHLH Option Kit	Yes	Yes	Yes	3	2	1	0	0	No	No
4XC7A86622	BT71	ThinkSystem SR850 V3 x16/x8/x8 PCIe G5 Riser 2/A/B/C HHLH Option Kit	Yes	Yes	Yes	3	0	0	2	1	No	No
<b>LP risers for Risers 2 and C with support for Serial port</b>												
CTO only	BT6Y	ThinkSystem SR850 V3 x16/x8/Serial PCIe G4 Riser 2/C HHLH	Yes	Yes	Yes	2	1	1	0	0	No	Yes
CTO only	BT72	ThinkSystem SR850 V3 x16/x8/Serial PCIe G5 Riser 2/C HHLH	Yes	Yes	Yes	2	0	0	1	1	No	Yes
<b>LP risers for Risers D)</b>												
4XC7A86701	BU8N	ThinkSystem SR850 V3 x8/x16/x16 PCIe G4 Riser D HHLH Option Kit	Yes	No	No	3	1	2	0	0	No	No
4XC7A86620	BT74	ThinkSystem SR850 V3 x8/x16/x16 PCIe G5 Riser D HHLH Option Kit	Yes	No	No	3	0	0	1	2	No	No

### Riser supported combinations - 3 risers

This section lists the supported combinations of riser when the SR850 V3 is configured to use base feature code BT68 or BT69 with full-height slots.

The SR850 V3 supports a mix of Gen5 and Gen4 PCIe slots using the combinations listed in the following table. The table also indicates which configurations support 7mm drives and which configurations support double-wide (DW) GPUs.

**Field upgrades:** It is supported to add riser cards using option part numbers as long as the target configuration is listed as supported in the table. Part numbers are listed in the [Riser ordering information](#) section.

Table 31. Riser combinations (Blue = Gen4, green = Gen5)

Riser count	Slots					7mm support	DW GPUs		Serial port support	Riser 1	Riser 2	Riser 3
	Total slots	G4 x8	G4 x16	G5 x8	G5 x16		GPU support	Remaining slots**				
1	3	1	2	0	0	No	Yes (1) (4S)	1	No	ThinkSystem SR850 V3 x8/x16/x16 PCIe G4 Riser 1/3 FHFL, <b>BT6W</b>	Empty	Empty
1	1	0	1	0	0	Yes	No	-	No	ThinkSystem SR850 V3 7mm/x16 PCIe G4 Riser 1 FHHL, <b>BT6Z</b>	Empty	Empty
2	6	2	4	0	0	No	Yes (2) (4S)	4	No	ThinkSystem SR850 V3 x8/x16/x16 PCIe G4 Riser 1/3 FHFL, <b>BT6W</b>	Empty	ThinkSystem SR850 V3 x8/x16/x16 PCIe G4 Riser 1/3 FHFL, <b>BT6W</b>
2	4	3	1	0	0	Yes	No	-	No	ThinkSystem SR850 V3 7mm/x16 PCIe G4 Riser 1 FHHL, <b>BT6Z</b>	Empty	ThinkSystem SR850 V3 x8/x16/x16 PCIe G4 Riser 1/3 FHFL, <b>BT6W</b>
2	6	3	3	0	0	No	Yes (1) (4S)	5	No	ThinkSystem SR850 V3 x8/x16/x16 PCIe G4 Riser 1/3 FHFL, <b>BT6W</b>	ThinkSystem SR850 V3 x16/x8/x8 PCIe G4 Riser 2/A/B/C HHHL, <b>BT6X</b>	Empty
2	5	3	2	0	0	No	Yes (1) (4S)	4	Yes	ThinkSystem SR850 V3 x8/x16/x16 PCIe G4 Riser 1/3 FHFL, <b>BT6W</b>	ThinkSystem SR850 V3 x16/x8/Serial PCIe G4 Riser 2/C HHHL, <b>BT6Y</b>	Empty
2	4	2	2	0	0	Yes	No	-	No	ThinkSystem SR850 V3 7mm/x16 PCIe G4 Riser 1 FHHL, <b>BT6Z</b>	ThinkSystem SR850 V3 x16/x8/x8 PCIe G4 Riser 2/A/B/C HHHL, <b>BT6X</b>	Empty



Riser count	Slots					7mm support	DW GPUs		Serial port support	Riser 1	Riser 2	Riser 3
	Total slots	G4 x8	G4 x16	G5 x8	G5 x16		GPU support	Remaining slots**				
2	3	1	2	0	0	Yes	No	-	Yes	ThinkSystem SR850 V3 7mm/x16 PCIe G4 Riser 1 FHHL, <b>BT6Z</b>	ThinkSystem SR850 V3 x16/x8/Serial PCIe G4 Riser 2/C HHHL, <b>BT6Y</b>	Empty
2	6	2	2	1	1	No	Yes (1) (4S)	5	No	ThinkSystem SR850 V3 x8/x16/x16 PCIe G4 Riser 1/3 FHFL, <b>BT6W</b>	ThinkSystem SR850 V3 x16/x8/x8 PCIe G5 Riser 2/A/B/C HHHL, <b>BT71</b>	Empty
2	5	1	2	1	1	No	Yes (1) (4S)	4	Yes	ThinkSystem SR850 V3 x8/x16/x16 PCIe G4 Riser 1/3 FHFL, <b>BT6W</b>	ThinkSystem SR850 V3 x16/x8/Serial PCIe G5 Riser 2/C HHHL, <b>BT72</b>	Empty
2	4	1	1	1	1	Yes	No	-	No	ThinkSystem SR850 V3 7mm/x16 PCIe G4 Riser 1 FHHL, <b>BT6Z</b>	ThinkSystem SR850 V3 x16/x8/x8 PCIe G5 Riser 2/A/B/C HHHL, <b>BT71</b>	Empty
2	3	0	1	1	1	Yes	No	-	Yes	ThinkSystem SR850 V3 7mm/x16 PCIe G4 Riser 1 FHHL, <b>BT6Z</b>	ThinkSystem SR850 V3 x16/x8/Serial PCIe G5 Riser 2/C HHHL, <b>BT72</b>	Empty
3	9	4	5	0	0	No	Yes (2) (4S)	7	No	ThinkSystem SR850 V3 x8/x16/x16 PCIe G4 Riser 1/3 FHFL, <b>BT6W</b>	ThinkSystem SR850 V3 x16/x8/x8 PCIe G4 Riser 2/A/B/C HHHL, <b>BT6X</b>	ThinkSystem SR850 V3 x8/x16/x16 PCIe G4 Riser 1/3 FHFL, <b>BT6W</b>
3	8	3	5	0	0	No	Yes (2) (4S)	6	Yes	ThinkSystem SR850 V3 x8/x16/x16 PCIe G4 Riser 1/3 FHFL, <b>BT6W</b>	ThinkSystem SR850 V3 x16/x8/Serial PCIe G4 Riser 2/C HHHL, <b>BT6Y</b>	ThinkSystem SR850 V3 x8/x16/x16 PCIe G4 Riser 1/3 FHFL, <b>BT6W</b>
3	7	3	4	0	0	Yes	No	-	No	ThinkSystem SR850 V3 7mm/x16 PCIe G4 Riser 1 FHHL, <b>BT6Z</b>	ThinkSystem SR850 V3 x16/x8/x8 PCIe G4 Riser 2/A/B/C HHHL, <b>BT6X</b>	ThinkSystem SR850 V3 x8/x16/x16 PCIe G4 Riser 1/3 FHFL, <b>BT6W</b>
3	6	2	4	0	0	Yes	No	-	Yes	ThinkSystem SR850 V3 7mm/x16 PCIe G4 Riser 1 FHHL, <b>BT6Z</b>	ThinkSystem SR850 V3 x16/x8/Serial PCIe G4 Riser 2/C HHHL, <b>BT6Y</b>	ThinkSystem SR850 V3 x8/x16/x16 PCIe G4 Riser 1/3 FHFL, <b>BT6W</b>

Riser count	Slots					7mm support	DW GPUs		Serial port support	Riser 1	Riser 2	Riser 3
	Total slots	G4 x8	G4 x16	G5 x8	G5 x16		GPU support	Remaining slots**				
3	9	3	4	1	1	No	Yes (2) (4S)	7	No	ThinkSystem SR850 V3 x8/x16/x16 PCIe G4 Riser 1/3 FHFL, <b>BT6W</b>	ThinkSystem SR850 V3 x16/x8/x8 PCIe G5 Riser 2/A/B/C HHHL, <b>BT71</b>	ThinkSystem SR850 V3 x8/x16/x16 PCIe G4 Riser 1/3 FHFL, <b>BT6W</b>
3	8	2	4	1	1	No	Yes (2) (4S)	6	Yes	ThinkSystem SR850 V3 x8/x16/x16 PCIe G4 Riser 1/3 FHFL, <b>BT6W</b>	ThinkSystem SR850 V3 x16/x8/Serial PCIe G5 Riser 2/C HHHL, <b>BT72</b>	ThinkSystem SR850 V3 x8/x16/x16 PCIe G4 Riser 1/3 FHFL, <b>BT6W</b>
3	7	2	3	1	1	Yes	No	-	No	ThinkSystem SR850 V3 7mm/x16 PCIe G4 Riser 1 FHHL, <b>BT6Z</b>	ThinkSystem SR850 V3 x16/x8/x8 PCIe G5 Riser 2/A/B/C HHHL, <b>BT71</b>	ThinkSystem SR850 V3 x8/x16/x16 PCIe G4 Riser 1/3 FHFL, <b>BT6W</b>
3	6	1	3	1	1	Yes	No	-	Yes	ThinkSystem SR850 V3 7mm/x16 PCIe G4 Riser 1 FHHL, <b>BT6Z</b>	ThinkSystem SR850 V3 x16/x8/Serial PCIe G5 Riser 2/C HHHL, <b>BT72</b>	ThinkSystem SR850 V3 x8/x16/x16 PCIe G4 Riser 1/3 FHFL, <b>BT6W</b>
1	2	0	0	0	2	No	Yes (1) (4S)	1	No	ThinkSystem SR850 V3 x16/x16 PCIe G5 Riser 1/3 FHFL, <b>BT70</b>	Empty	Empty
1	1	0	0	0	1	Yes	No	-	No	ThinkSystem SR850 V3 7mm/x16 PCIe G5 Riser 1 FHHL, <b>BT73</b>	Empty	Empty
2	4	0	0	0	4	No	Yes (2) (4S)	4	No	ThinkSystem SR850 V3 x16/x16 PCIe G5 Riser 1/3 FHFL, <b>BT70</b>	Empty	ThinkSystem SR850 V3 x16/x16 PCIe G5 Riser 1/3 FHFL, <b>BT70</b>
2	3	0	0	0	3	Yes	No	-	No	ThinkSystem SR850 V3 7mm/x16 PCIe G5 Riser 1 FHHL, <b>BT73</b>	Empty	ThinkSystem SR850 V3 x16/x16 PCIe G5 Riser 1/3 FHFL, <b>BT70</b>
2	5	2	1	0	2	No	Yes (1) (4S)	5	No	ThinkSystem SR850 V3 x16/x16 PCIe G5 Riser 1/3 FHFL, <b>BT70</b>	ThinkSystem SR850 V3 x16/x8/x8 PCIe G4 Riser 2/A/B/C HHHL, <b>BT6X</b>	Empty
2	4	1	1	0	2	No	Yes (1) (4S)	4	Yes	ThinkSystem SR850 V3 x16/x16 PCIe G5 Riser 1/3 FHFL, <b>BT70</b>	ThinkSystem SR850 V3 x16/x8/Serial PCIe G4 Riser 2/C HHHL, <b>BT6Y</b>	Empty

Riser count	Slots					7mm support	DW GPUs		Serial port support	Riser 1	Riser 2	Riser 3
	Total slots	G4 x8	G4 x16	G5 x8	G5 x16		GPU support	Remaining slots**				
2	4	2	1	0	1	Yes	No	-	No	ThinkSystem SR850 V3 7mm/x16 PCIe G5 Riser 1 FHHL, <b>BT73</b>	ThinkSystem SR850 V3 x16/x8/x8 PCIe G4 Riser 2/A/B/C HHHL, <b>BT6X</b>	Empty
2	3	1	1	0	1	Yes	No	-	Yes	ThinkSystem SR850 V3 7mm/x16 PCIe G5 Riser 1 FHHL, <b>BT73</b>	ThinkSystem SR850 V3 x16/x8/Serial PCIe G4 Riser 2/C HHHL, <b>BT6Y</b>	Empty
2	5	1	0	1	3	No	Yes (1) (4S)	5	No	ThinkSystem SR850 V3 x16/x16 PCIe G5 Riser 1/3 FHFL, <b>BT70</b>	ThinkSystem SR850 V3 x16/x8/x8 PCIe G5 Riser 2/A/B/C HHHL, <b>BT71</b>	Empty
2	4	0	0	1	3	No	Yes (1) (4S)	4	Yes	ThinkSystem SR850 V3 x16/x16 PCIe G5 Riser 1/3 FHFL, <b>BT70</b>	ThinkSystem SR850 V3 x16/x8/Serial PCIe G5 Riser 2/C HHHL, <b>BT72</b>	Empty
2	4	1	0	1	2	Yes	No	-	No	ThinkSystem SR850 V3 7mm/x16 PCIe G5 Riser 1 FHHL, <b>BT73</b>	ThinkSystem SR850 V3 x16/x8/x8 PCIe G5 Riser 2/A/B/C HHHL, <b>BT71</b>	Empty
2	3	0	0	1	2	Yes	No	-	Yes	ThinkSystem SR850 V3 7mm/x16 PCIe G5 Riser 1 FHHL, <b>BT73</b>	ThinkSystem SR850 V3 x16/x8/Serial PCIe G5 Riser 2/C HHHL, <b>BT72</b>	Empty
3	7	2	1	0	4	No	Yes (2) (4S)	7	No	ThinkSystem SR850 V3 x16/x16 PCIe G5 Riser 1/3 FHFL, <b>BT70</b>	ThinkSystem SR850 V3 x16/x8/x8 PCIe G4 Riser 2/A/B/C HHHL, <b>BT6X</b>	ThinkSystem SR850 V3 x16/x16 PCIe G5 Riser 1/3 FHFL, <b>BT70</b>
3	6	1	1	0	4	No	Yes (2) (4S)	6	Yes	ThinkSystem SR850 V3 x16/x16 PCIe G5 Riser 1/3 FHFL, <b>BT70</b>	ThinkSystem SR850 V3 x16/x8/Serial PCIe G4 Riser 2/C HHHL, <b>BT6Y</b>	ThinkSystem SR850 V3 x16/x16 PCIe G5 Riser 1/3 FHFL, <b>BT70</b>
3	6	2	1	0	3	Yes	No	-	No	ThinkSystem SR850 V3 7mm/x16 PCIe G5 Riser 1 FHHL, <b>BT73</b>	ThinkSystem SR850 V3 x16/x8/x8 PCIe G4 Riser 2/A/B/C HHHL, <b>BT6X</b>	ThinkSystem SR850 V3 x16/x16 PCIe G5 Riser 1/3 FHFL, <b>BT70</b>

Riser count	Slots					7mm support	DW GPUs		Serial port support	Riser 1	Riser 2	Riser 3
	Total slots	G4 x8	G4 x16	G5 x8	G5 x16		GPU support	Remaining slots**				
3	5	1	1	0	3	Yes	No	-	Yes	ThinkSystem SR850 V3 7mm/x16 PCIe G5 Riser 1 FHHL, <b>BT73</b>	ThinkSystem SR850 V3 x16/x8/Serial PCIe G4 Riser 2/C HHHL, <b>BT6Y</b>	ThinkSystem SR850 V3 x16/x16 PCIe G5 Riser 1/3 FHFL, <b>BT70</b>
3	7	1	0	1	5	No	Yes (2) (4S)	7	No	ThinkSystem SR850 V3 x16/x16 PCIe G5 Riser 1/3 FHFL, <b>BT70</b>	ThinkSystem SR850 V3 x16/x8/x8 PCIe G5 Riser 2/A/B/C HHHL, <b>BT71</b>	ThinkSystem SR850 V3 x16/x16 PCIe G5 Riser 1/3 FHFL, <b>BT70</b>
3	6	0	0	1	5	No	Yes (2) (4S)	6	Yes	ThinkSystem SR850 V3 x16/x16 PCIe G5 Riser 1/3 FHFL, <b>BT70</b>	ThinkSystem SR850 V3 x16/x8/Serial PCIe G5 Riser 2/C HHHL, <b>BT72</b>	ThinkSystem SR850 V3 x16/x16 PCIe G5 Riser 1/3 FHFL, <b>BT70</b>
3	6	1	0	1	4	Yes	No	-	No	ThinkSystem SR850 V3 7mm/x16 PCIe G5 Riser 1 FHHL, <b>BT73</b>	ThinkSystem SR850 V3 x16/x8/x8 PCIe G5 Riser 2/A/B/C HHHL, <b>BT71</b>	ThinkSystem SR850 V3 x16/x16 PCIe G5 Riser 1/3 FHFL, <b>BT70</b>
3	5	0	0	1	4	Yes	No	-	Yes	ThinkSystem SR850 V3 7mm/x16 PCIe G5 Riser 1 FHHL, <b>BT73</b>	ThinkSystem SR850 V3 x16/x8/Serial PCIe G5 Riser 2/C HHHL, <b>BT72</b>	ThinkSystem SR850 V3 x16/x16 PCIe G5 Riser 1/3 FHFL, <b>BT70</b>

\*\* For configurations with support for double-wide GPUs, this is the number of slots remaining available after the maximum number of GPUs are installed

**Physically x16 slots:** All of the x8 slots have a physical x16 connector. This means that the slot mechanically accepts an adapter that has the longer x16 edge connector. However since the slot is electrically x8, it only has eight PCIe lanes for data transfer and only has the performance of a x8 slot.

### Riser supported combinations - 4 risers

This section lists the supported combinations of riser when the SR850 V3 is configured to use base feature code BT67 with 12 low-profile slots and no full-height slots.

The SR850 V3 supports a mix of Gen5 and Gen4 PCIe slots using the combinations listed in the following table. 7mm drives and double-wide GPUs are not supported in base BT67.

**Field upgrades:** It is supported to add riser cards using option part numbers as long as the target configuration is listed as supported in the table. Part numbers are listed in the [Riser ordering information](#) section.

Table 32. Riser combinations (Blue = Gen4, green = Gen5)

Riser count	Slots					7mm support	DW GPU support	Serial port support	Riser 1	Riser 2	Riser 3	Riser 4
	Total slots	G4 x8	G4 x16	G5 x8	G5 x16							
1	3	2	1	0	0	No	No	No	ThinkSystem SR850 V3 x16/x8/x8 PCIe G4 Riser 2/A/B/C HHHL, <b>BT6X</b>	Empty	Empty	Empty
2	6	4	2	0	0	No	No	No	ThinkSystem SR850 V3 x16/x8/x8 PCIe G4 Riser 2/A/B/C HHHL, <b>BT6X</b>	ThinkSystem SR850 V3 x16/x8/x8 PCIe G4 Riser 2/A/B/C HHHL, <b>BT6X</b>	Empty	Empty
2	6	4	2	0	0	No	No	No	ThinkSystem SR850 V3 x16/x8/x8 PCIe G4 Riser 2/A/B/C HHHL, <b>BT6X</b>	Empty	ThinkSystem SR850 V3 x16/x8/x8 PCIe G4 Riser 2/A/B/C HHHL, <b>BT6X</b>	Empty
2	5	3	2	0	0	No	No	Yes	ThinkSystem SR850 V3 x16/x8/x8 PCIe G4 Riser 2/A/B/C HHHL, <b>BT6X</b>	Empty	ThinkSystem SR850 V3 x16/x8/Serial PCIe G4 Riser 2/C HHHL, <b>BT6Y</b>	Empty
2	6	3	3	0	0	No	No	No	ThinkSystem SR850 V3 x16/x8/x8 PCIe G4 Riser 2/A/B/C HHHL, <b>BT6X</b>	Empty	Empty	ThinkSystem SR850 V3 x8/x16/x16 PCIe G4 Riser D HHHL, <b>BU8N</b>
2	6	2	2	1	1	No	No	No	ThinkSystem SR850 V3 x16/x8/x8 PCIe G4 Riser 2/A/B/C HHHL, <b>BT6X</b>	Empty	Empty	ThinkSystem SR850 V3 x8/x16/x16 PCIe G5 Riser D HHHL, <b>BT74</b>
3	9	6	3	0	0	No	No	No	ThinkSystem SR850 V3 x16/x8/x8 PCIe G4 Riser 2/A/B/C HHHL, <b>BT6X</b>	ThinkSystem SR850 V3 x16/x8/x8 PCIe G4 Riser 2/A/B/C HHHL, <b>BT6X</b>	ThinkSystem SR850 V3 x16/x8/x8 PCIe G4 Riser 2/A/B/C HHHL, <b>BT6X</b>	Empty
3	8	5	3	0	0	No	No	Yes	ThinkSystem SR850 V3 x16/x8/x8 PCIe G4 Riser 2/A/B/C HHHL, <b>BT6X</b>	ThinkSystem SR850 V3 x16/x8/x8 PCIe G4 Riser 2/A/B/C HHHL, <b>BT6X</b>	ThinkSystem SR850 V3 x16/x8/Serial PCIe G4 Riser 2/C HHHL, <b>BT6Y</b>	Empty

Riser count	Slots					7mm support	DW GPU support	Serial port support	Riser 1	Riser 2	Riser 3	Riser 4
	Total slots	G4 x8	G4 x16	G5 x8	G5 x16							
3	9	4	5	0	0	No	No	No	ThinkSystem SR850 V3 x16/x8/x8 PCIe G4 Riser 2/A/B/C HHHL, <b>BT6X</b>	ThinkSystem SR850 V3 x16/x8/x8 PCIe G4 Riser 2/A/B/C HHHL, <b>BT6X</b>	Empty	ThinkSystem SR850 V3 x8/x16/x16 PCIe G4 Riser D HHHL, <b>BU8N</b>
3	9	4	3	1	1	No	No	No	ThinkSystem SR850 V3 x16/x8/x8 PCIe G4 Riser 2/A/B/C HHHL, <b>BT6X</b>	ThinkSystem SR850 V3 x16/x8/x8 PCIe G4 Riser 2/A/B/C HHHL, <b>BT6X</b>	Empty	ThinkSystem SR850 V3 x8/x16/x16 PCIe G5 Riser D HHHL, <b>BT74</b>
4	12	7	5	0	0	No	No	No	ThinkSystem SR850 V3 x16/x8/x8 PCIe G4 Riser 2/A/B/C HHHL, <b>BT6X</b>	ThinkSystem SR850 V3 x16/x8/x8 PCIe G4 Riser 2/A/B/C HHHL, <b>BT6X</b>	ThinkSystem SR850 V3 x16/x8/x8 PCIe G4 Riser 2/A/B/C HHHL, <b>BT6X</b>	ThinkSystem SR850 V3 x8/x16/x16 PCIe G4 Riser D HHHL, <b>BU8N</b>
4	11	6	5	0	0	No	No	Yes	ThinkSystem SR850 V3 x16/x8/x8 PCIe G4 Riser 2/A/B/C HHHL, <b>BT6X</b>	ThinkSystem SR850 V3 x16/x8/x8 PCIe G4 Riser 2/A/B/C HHHL, <b>BT6X</b>	ThinkSystem SR850 V3 x16/x8/Serial PCIe G4 Riser 2/C HHHL, <b>BT6Y</b>	ThinkSystem SR850 V3 x8/x16/x16 PCIe G4 Riser D HHHL, <b>BU8N</b>
4	12	6	4	1	1	No	No	No	ThinkSystem SR850 V3 x16/x8/x8 PCIe G4 Riser 2/A/B/C HHHL, <b>BT6X</b>	ThinkSystem SR850 V3 x16/x8/x8 PCIe G4 Riser 2/A/B/C HHHL, <b>BT6X</b>	ThinkSystem SR850 V3 x16/x8/x8 PCIe G4 Riser 2/A/B/C HHHL, <b>BT6X</b>	ThinkSystem SR850 V3 x8/x16/x16 PCIe G5 Riser D HHHL, <b>BT74</b>
4	11	5	4	1	1	No	No	Yes	ThinkSystem SR850 V3 x16/x8/x8 PCIe G4 Riser 2/A/B/C HHHL, <b>BT6X</b>	ThinkSystem SR850 V3 x16/x8/x8 PCIe G4 Riser 2/A/B/C HHHL, <b>BT6X</b>	ThinkSystem SR850 V3 x16/x8/Serial PCIe G4 Riser 2/C HHHL, <b>BT6Y</b>	ThinkSystem SR850 V3 x8/x16/x16 PCIe G5 Riser D HHHL, <b>BT74</b>
1	3	1	0	1	1	No	No	No	ThinkSystem SR850 V3 x16/x8/x8 PCIe G5 Riser 2/A/B/C HHHL, <b>BT71</b>	Empty	Empty	Empty
2	6	2	0	2	2	No	No	No	ThinkSystem SR850 V3 x16/x8/x8 PCIe G5 Riser 2/A/B/C HHHL, <b>BT71</b>	ThinkSystem SR850 V3 x16/x8/x8 PCIe G5 Riser 2/A/B/C HHHL, <b>BT71</b>	Empty	Empty

Riser count	Slots				7mm support	DW GPU support	Serial port support	Riser 1	Riser 2	Riser 3	Riser 4	
	Total slots	G4 x8	G4 x16	G5 x8								G5 x16
2	6	2	0	2	2	No	No	No	ThinkSystem SR850 V3 x16/x8/x8 PCIe G5 Riser 2/A/B/C HHHL, <b>BT71</b>	Empty	ThinkSystem SR850 V3 x16/x8/x8 PCIe G5 Riser 2/A/B/C HHHL, <b>BT71</b>	Empty
2	5	2	0	2	2	No	No	Yes	ThinkSystem SR850 V3 x16/x8/x8 PCIe G5 Riser 2/A/B/C HHHL, <b>BT71</b>	Empty	ThinkSystem SR850 V3 x16/x8/Serial PCIe G5 Riser 2/C HHHL, <b>BT72</b>	Empty
2	6	2	2	1	1	No	No	No	ThinkSystem SR850 V3 x16/x8/x8 PCIe G5 Riser 2/A/B/C HHHL, <b>BT71</b>	Empty	Empty	ThinkSystem SR850 V3 x8/x16/x16 PCIe G4 Riser D HHHL, <b>BU8N</b>
2	6	1	1	2	2	No	No	No	ThinkSystem SR850 V3 x16/x8/x8 PCIe G5 Riser 2/A/B/C HHHL, <b>BT71</b>	Empty	Empty	ThinkSystem SR850 V3 x8/x16/x16 PCIe G5 Riser D HHHL, <b>BT74</b>
3	9	3	0	3	3	No	No	No	ThinkSystem SR850 V3 x16/x8/x8 PCIe G5 Riser 2/A/B/C HHHL, <b>BT71</b>	ThinkSystem SR850 V3 x16/x8/x8 PCIe G5 Riser 2/A/B/C HHHL, <b>BT71</b>	ThinkSystem SR850 V3 x16/x8/x8 PCIe G5 Riser 2/A/B/C HHHL, <b>BT71</b>	Empty
3	8	2	0	3	3	No	No	Yes	ThinkSystem SR850 V3 x16/x8/x8 PCIe G5 Riser 2/A/B/C HHHL, <b>BT71</b>	ThinkSystem SR850 V3 x16/x8/x8 PCIe G5 Riser 2/A/B/C HHHL, <b>BT71</b>	ThinkSystem SR850 V3 x16/x8/Serial PCIe G5 Riser 2/C HHHL, <b>BT72</b>	Empty
3	9	3	2	2	2	No	No	No	ThinkSystem SR850 V3 x16/x8/x8 PCIe G5 Riser 2/A/B/C HHHL, <b>BT71</b>	ThinkSystem SR850 V3 x16/x8/x8 PCIe G5 Riser 2/A/B/C HHHL, <b>BT71</b>	Empty	ThinkSystem SR850 V3 x8/x16/x16 PCIe G4 Riser D HHHL, <b>BU8N</b>
3	9	2	1	3	3	No	No	No	ThinkSystem SR850 V3 x16/x8/x8 PCIe G5 Riser 2/A/B/C HHHL, <b>BT71</b>	ThinkSystem SR850 V3 x16/x8/x8 PCIe G5 Riser 2/A/B/C HHHL, <b>BT71</b>	Empty	ThinkSystem SR850 V3 x8/x16/x16 PCIe G5 Riser D HHHL, <b>BT74</b>

Riser count	Slots				7mm support	DW GPU support	Serial port support	Riser 1	Riser 2	Riser 3	Riser 4	
	Total slots	G4 x8	G4 x16	G5 x8								G5 x16
4	12	4	2	3	3	No	No	No	ThinkSystem SR850 V3 x16/x8/x8 PCIe G5 Riser 2/A/B/C HHHL, <b>BT71</b>	ThinkSystem SR850 V3 x16/x8/x8 PCIe G5 Riser 2/A/B/C HHHL, <b>BT71</b>	ThinkSystem SR850 V3 x16/x8/x8 PCIe G5 Riser 2/A/B/C HHHL, <b>BT71</b>	ThinkSystem SR850 V3 x8/x16/x16 PCIe G5 Riser D HHHL, <b>BU8N</b>
4	11	3	2	3	3	No	No	Yes	ThinkSystem SR850 V3 x16/x8/x8 PCIe G5 Riser 2/A/B/C HHHL, <b>BT71</b>	ThinkSystem SR850 V3 x16/x8/x8 PCIe G5 Riser 2/A/B/C HHHL, <b>BT71</b>	ThinkSystem SR850 V3 x16/x8/Serial PCIe G5 Riser 2/C HHHL, <b>BT72</b>	ThinkSystem SR850 V3 x8/x16/x16 PCIe G4 Riser D HHHL, <b>BU8N</b>
4	12	3	1	4	4	No	No	No	ThinkSystem SR850 V3 x16/x8/x8 PCIe G5 Riser 2/A/B/C HHHL, <b>BT71</b>	ThinkSystem SR850 V3 x16/x8/x8 PCIe G5 Riser 2/A/B/C HHHL, <b>BT71</b>	ThinkSystem SR850 V3 x16/x8/x8 PCIe G5 Riser 2/A/B/C HHHL, <b>BT71</b>	ThinkSystem SR850 V3 x8/x16/x16 PCIe G5 Riser D HHHL, <b>BT74</b>
4	11	2	1	4	4	No	No	Yes	ThinkSystem SR850 V3 x16/x8/x8 PCIe G5 Riser 2/A/B/C HHHL, <b>BT71</b>	ThinkSystem SR850 V3 x16/x8/x8 PCIe G5 Riser 2/A/B/C HHHL, <b>BT71</b>	ThinkSystem SR850 V3 x16/x8/Serial PCIe G5 Riser 2/C HHHL, <b>BT72</b>	ThinkSystem SR850 V3 x8/x16/x16 PCIe G5 Riser D HHHL, <b>BT74</b>

**Physically x16 slots:** All of the x8 slots have a physical x16 connector. This means that the slot mechanically accepts an adapter that has the longer x16 edge connector. However since the slot is electrically x8, it only has eight PCIe lanes for data transfer and only has the performance of a x8 slot.

## Network adapters

The SR850 V3 has two dedicated OCP 3.0 SFF slots with PCIe 5.0 x16 host interfaces. See [Figure 3](#) for the location of the OCP slots.

The following table lists the supported OCP adapters. One port of each adapter can optionally be shared with the XCC management processor for Wake-on-LAN and NC-SI support.



Table 33. OCP adapters

Part number	Feature code	Description	Maximum supported
Gigabit Ethernet			
4XC7A08235	B5T1	ThinkSystem Broadcom 5719 1GbE RJ45 4-port OCP Ethernet Adapter	2
4XC7A88428	BW97	ThinkSystem Intel I350 1GbE RJ45 4-Port OCP Ethernet Adapter V2	2
4XC7A08277	B93E	ThinkSystem Intel I350 1GbE RJ45 4-port OCP Ethernet Adapter	1
10 Gb Ethernet - 10GBASE-T			
4XC7A08236	B5ST	ThinkSystem Broadcom 57416 10GBASE-T 2-port OCP Ethernet Adapter	2
4XC7A08240	B5T4	ThinkSystem Broadcom 57454 10GBASE-T 4-port OCP Ethernet Adapter	2
4XC7A08278	BCD5	ThinkSystem Intel X710-T2L 10GBASE-T 2-port OCP Ethernet Adapter	2
4XC7A80268	BPPY	ThinkSystem Intel X710-T4L 10GBase-T 4-Port OCP Ethernet Adapter	2
25 Gb Ethernet			
4XC7A08237	BN2T	ThinkSystem Broadcom 57414 10/25GbE SFP28 2-Port OCP Ethernet Adapter	2
4XC7A80567	BPPW	ThinkSystem Broadcom 57504 10/25GbE SFP28 4-Port OCP Ethernet Adapter	2
4XC7A08294	BCD4	ThinkSystem Intel E810-DA2 10/25GbE SFP28 2-Port OCP Ethernet Adapter	2
4XC7A80269	BP8L	ThinkSystem Intel E810-DA4 10/25GbE SFP28 4-Port OCP Ethernet Adapter	1
4XC7A62582	BE4T	ThinkSystem Mellanox ConnectX-6 Lx 10/25GbE SFP28 2-Port OCP Ethernet Adapter	2
100 Gb Ethernet			
4XC7A08243	BPPX	ThinkSystem Broadcom 57508 100GbE QSFP56 2-Port OCP Ethernet Adapter	2

The following table lists additional supported network adapters that can be installed in the regular PCIe slots.

**Legacy Option ROM support:** The server does not support legacy option boot ROM on PCIe adapters connected to CPU 3 or 4. See the [I/O expansion](#) section for details on which slots connect to each CPU. For option ROM support, install the adapters in slots connected to CPU 1 or 2, or use UEFI boot mode on those adapters instead.

**Intel E810 adapter support:** The Intel E810 PCIe adapters are currently limited to quantity 1 in the SR850 V3. Support for larger quantities is planned for 4Q/2023.

Table 34. PCIe network adapters

Part number	Feature code	Description	Maximum supported
<b>Gigabit Ethernet</b>			
7ZT7A00484	AUZV	ThinkSystem Broadcom 5719 1GbE RJ45 4-Port PCIe Ethernet Adapter	11
7ZT7A00535	AUZW	ThinkSystem I350-T4 PCIe 1Gb 4-Port RJ45 Ethernet Adapter	11
<b>10 Gb Ethernet - 10GBASE-T</b>			
7ZT7A00496	AUKP	ThinkSystem Broadcom 57416 10GBASE-T 2-Port PCIe Ethernet Adapter	12
4XC7A08245	B5SU	ThinkSystem Broadcom 57454 10GBASE-T 4-port PCIe Ethernet Adapter	11
4XC7A80266	BNWL	ThinkSystem Intel X710-T2L 10GBase-T 2-Port PCIe Ethernet Adapter	12
4XC7A79699	BMXB	ThinkSystem Intel X710-T4L 10GBase-T 4-Port PCIe Ethernet Adapter	11
<b>25 Gb Ethernet</b>			
4XC7A08238	BK1H	ThinkSystem Broadcom 57414 10/25GbE SFP28 2-port PCIe Ethernet Adapter	12
4XC7A80566	BNWM	ThinkSystem Broadcom 57504 10/25GbE SFP28 4-Port PCIe Ethernet Adapter	4†
4XC7A08295	BCD6	ThinkSystem Intel E810-DA2 10/25GbE SFP28 2-Port PCIe Ethernet Adapter	1
4XC7A80267	BP8M	ThinkSystem Intel E810-DA4 10/25GbE SFP28 4-Port PCIe Ethernet Adapter	1†
4XC7A62580	BE4U	ThinkSystem Mellanox ConnectX-6 Lx 10/25GbE SFP28 2-Port PCIe Ethernet Adapter	5
<b>100 Gb Ethernet and HDR100 InfiniBand</b>			
4XC7A08297	BK1J	ThinkSystem Broadcom 57508 100GbE QSFP56 2-port PCIe 4 Ethernet Adapter	5
4XC7A08248	B8PP	ThinkSystem Mellanox ConnectX-6 Dx 100GbE QSFP56 2-port PCIe 4 Ethernet Adapter	5*
4C57A14178	B4RA	ThinkSystem Mellanox ConnectX-6 HDR100/100GbE QSFP56 2-port PCIe VPI Adapter	5*
4C57A14177	B4R9	ThinkSystem Mellanox ConnectX-6 HDR100/100GbE QSFP56 1-port PCIe VPI Adapter	5*
<b>HDR and NDR200 InfiniBand (200 GbE)</b>			
4XC7A81883	BQBK	ThinkSystem NVIDIA ConnectX-7 NDR200/200GbE QSFP112 2-port PCIe Gen5 x16 InfiniBand Adapter	5*
4C57A15326	B4RC	ThinkSystem Mellanox ConnectX-6 HDR/200GbE QSFP56 1-port PCIe 4 VPI Adapter	5*
4XC7A81089	BM0Q	ThinkSystem Mellanox ConnectX-6 HDR/200GbE QSFP56 2-port PCIe 4 VPI Adapter	5*
4C57A80293	BNDQ	ThinkSystem NVIDIA PCIe Gen4 x16 Passive Aux Kit (Supports Socket-Direct Mode)	1†
<b>NDR InfiniBand (400 GbE)</b>			
4XC7A80289	BQ1N	ThinkSystem NVIDIA ConnectX-7 NDR OSFP400 1-Port PCIe Gen5 x16 InfiniBand Adapter	5*

\* With this adapter installed, the server only supports 2x drive backplanes. See [Front drive bays](#) section  
 † Not supported with Base BT67, ThinkSystem SR850 V3 Standard 2U/4S Base with LP PCIe

For details about these adapters, see the relevant product guide:

- Ethernet adapters: <https://lenovopress.com/servers/options/ethernet>
- InfiniBand adapters: <https://lenovopress.com/servers/options/infiniband>

## Fibre Channel host bus adapters

The following table lists the Fibre Channel HBAs supported by the server.

**Legacy Option ROM support:** The server does not support legacy option boot ROM on PCIe adapters connected to CPU 3 or 4. See the [I/O expansion](#) section for details on which slots connect to each CPU. For option ROM support, install the adapters in slots connected to CPU 1 or 2, or use UEFI boot mode on those adapters instead.

Table 35. Fibre Channel HBAs

Part number	Feature code	Description	Maximum supported	Slots supported
<b>16Gb Fibre Channel</b>				
01CV840	ATZV	Emulex 16Gb Gen6 FC Dual-port HBA	12	All slots
01CV830	ATZU	Emulex 16Gb Gen6 FC Single-port HBA	12	All slots
01CV760	ATZC	QLogic 16Gb Enhanced Gen5 FC Dual-port HBA	12	All slots
01CV750	ATZB	QLogic 16Gb Enhanced Gen5 FC Single-port HBA	12	All slots
<b>32Gb Fibre Channel</b>				
4XC7A76498	BJ3G	ThinkSystem Emulex LPe35000 32Gb 1-port PCIe Fibre Channel Adapter v2	12	All slots
4XC7A76525	BJ3H	ThinkSystem Emulex LPe35002 32Gb 2-port PCIe Fibre Channel Adapter V2	12	All slots
4XC7A08279	BA1G	ThinkSystem QLogic QLE2770 32Gb 1-Port PCIe Fibre Channel Adapter	12	All slots
4XC7A08276	BA1F	ThinkSystem QLogic QLE2772 32Gb 2-Port PCIe Fibre Channel Adapter	12	All slots
<b>64Gb Fibre Channel</b>				
4XC7A77485	BLC1	ThinkSystem Emulex LPe36002 64Gb 2-port PCIe Fibre Channel Adapter	12	All slots

For more information, see the list of Lenovo Press Product Guides in the Host bus adapters category: <https://lenovopress.com/servers/options/hba>

## SAS adapters for external storage

The following table lists SAS HBAs and RAID adapters supported by the server for use with external storage.

**Legacy Option ROM support:** The server does not support legacy option boot ROM on PCIe adapters connected to CPU 3 or 4. See the [I/O expansion](#) section for details on which slots connect to each CPU. For option ROM support, install the adapters in slots connected to CPU 1 or 2, or use UEFI boot mode on those adapters instead.

Table 36. Adapters for external storage

Part number	Feature code	Description	Maximum supported	Slots supported
SAS HBA - PCIe 4.0				
4Y37A09724	B8P7	ThinkSystem 440-16e SAS/SATA PCIe Gen4 12Gb HBA	8	All slots
4Y37A78837	BNWK	ThinkSystem 440-8e SAS/SATA PCIe Gen4 12Gb HBA	8	All slots
RAID Adapter - PCIe 4.0				
4Y37A78836	BNWJ	ThinkSystem RAID 940-8e 4GB Flash PCIe Gen4 12Gb Adapter	2	All slots

For a comparison of the functions of the supported storage adapters, see the ThinkSystem RAID Adapter and HBA Reference:

<https://lenovopress.lenovo.com/lp1288#sr850-v3-support=SR850%2520V3&internal-or-external-ports=External>

The RAID 940-8e adapter uses a flash power module (supercap) and the server supports up to two supercaps. The number of 940-8e RAID adapters supported is based on how many supercaps can be installed in the server. For example, if your configuration uses a RAID 940/9350 adapter for internal storage, then you can only install one RAID 940-8e adapter, since there is only space for two supercaps total.

For details about these adapters, see the relevant product guide:

- SAS HBAs: <https://lenovopress.com/servers/options/hba>
- RAID adapters: <https://lenovopress.com/servers/options/raid>

## Flash storage adapters

The SR850 V3 currently does not support PCIe Flash Storage adapters.

## GPU adapters

The SR850 V3 supports the graphics processing units (GPUs) listed in the following table:

**GPU support:** For CTO orders, to support GPUs (single-wide or double-wide), you will need to select base BT69. See the [Models](#) section for details. When adding GPUs to an existing server, GPUs are only supported when the server is configured in the factory with full-length slots and low-profile heatsinks on the rear processors. Field upgrades of the heatsinks and slots are not available.

Table 37. GPU adapters

Part number	Feature code	Description	Maximum supported
Single-wide GPUs			
4X67A84824	BS2C	ThinkSystem NVIDIA L4 24GB PCIe Gen4 Passive GPU	4
Double-wide GPUs			
4X67A84823	BT87	ThinkSystem NVIDIA L40 48GB PCIe Gen4 Passive GPU	2
4X67A81102	BP04	ThinkSystem AMD Instinct MI210 PCIe Gen4 Passive Accelerator	2
4X67A82257	BR9U	ThinkSystem NVIDIA H100 80GB PCIe Gen5 Passive GPU (not available in China, Hong Kong, Macau)	2
4X67A76715	BLK1	ThinkSystem NVIDIA A100 80GB PCIe Gen4 Passive GPU (not available in China, Hong Kong, Macau)	2
CTO only	BQZP	ThinkSystem NVIDIA A100 80GB PCIe Gen4 Passive GPU w/o CEC	2
4X67A71310	BFT0	ThinkSystem NVIDIA RTX A6000 48GB PCIe Active GPU	2
4X67A76726	BNFD	ThinkSystem NVIDIA RTX A4500 20GB PCIe Active GPU	2

**Tip:** The SR850 V3 does not support the NVIDIA Ampere NVLink 2-Slot Bridge

For details about these GPUs, see the ThinkSystem and ThinkAgile GPU Summary:

<https://lenovopress.com/lp0768-thinksystem-thinkagile-gpu-summary>

The following rules apply when using GPUs:

- Installed GPUs must be identical
- Base feature code BT69 is required. See the [Models](#) section for details.
- For double-wide GPUs:
  - Only the 6416H processor (TDP ≤ 165W) is supported
  - 256GB 3DS RDIMMs are not supported (to be confirmed)
- Some NVIDIA A Series GPUs are available as two feature codes, one with a CEC chip and one without a CEC chip (ones without the CEC chip have "w/o CEC" in the name). The CEC is a secondary Hardware Root of Trust (RoT) module that provides an additional layer of security, which can be used by customers who have high regulatory requirements or high security standards. NVIDIA uses a multi-layered security model and hence the protection offered by the primary Root of Trust embedded in the GPU is expected to be sufficient for most customers. The CEC defeatured products still offer Secure Boot, Secure Firmware Update, Firmware Rollback Protection, and In-Band Firmware Update Disable. Specifically, without the CEC chip, the GPU does not support Key Revocation or Firmware Attestation. CEC and non-CEC GPUs of the same type of GPU can be mixed in field upgrades.

Double-wide GPUs require an auxiliary power cable. For CTO orders, the necessary auxiliary power cables are automatically selected as part of configuration. For field upgrades, you will need to also order the power cable separately, as listed in the following table. One part number is needed per GPU.

Table 38. Auxiliary power cables

Part number	Feature code	Description
4X97A88017	BW29	ThinkSystem SR850 V3/SR860 V3 A100/A6000/MI210 GPU Power Cable Option Kit
4X97A88016	BW28	ThinkSystem SR850 V3/SR860 V3 H100 GPU Power Cable Option Kit
4X97A88015	BW27	ThinkSystem SR850 V3/SR860 V3 A4500 GPU Power Cable Option Kit

## Cooling

The SR850 V3 server has six 60 mm hot-swap dual-rotor variable-speed fans and all six fans are standard in all models. The server offers N+1 redundancy, meaning that one fan can fail and the server still operates normally.

In addition, each power supply has an integrated fan and a fan is connected to each of the two upper riser units.

## Power supplies

The server supports up to two redundant hot-swap power supplies. Redundancy can be configured as N+1.

**Tip:** Use Lenovo Capacity Planner to determine exactly what power your server needs:  
<https://datacentersupport.lenovo.com/us/en/products/solutions-and-software/software/lenovo-capacity-planner/solutions/ht504651>

Table 39. Power supply options for SR850 V3

Part number	Feature code	Description	Connector	Supported quantities	110V support
<b>Titanium power supplies (available in all markets)</b>					
4P57A72666	BLKH	ThinkSystem 1100W 230V Titanium Hot-Swap Gen2 Power Supply	C13	2	No
4P57A78359	BPK9	ThinkSystem 1800W 230V Titanium Hot-Swap Gen2 Power Supply	C13	2	No
4P57A72667	BKTJ	ThinkSystem 2600W 230V Titanium Hot-Swap Gen2 Power Supply	C19	2	No
<b>Platinum power supplies (available in all markets)</b>					
4P57A72671	BNFH	ThinkSystem 1100W 230V/115V Platinum Hot-Swap Gen2 Power Supply v3	C13	2	Yes
4P57A26294	BMUF	ThinkSystem 1800W 230V Platinum Hot-Swap Gen2 Power Supply	C13	2	No
4P57A26295	B962	ThinkSystem 2400W 230V Platinum Hot-Swap Gen2 Power Supply	C19	2	No
<b>Power supplies for customers in China only</b>					
4P57A82017	BTTP	ThinkSystem 1600W 336V HVDC CRPS Hot-Swap Power Supply (PRC)	DC	2	No
4P57A78364	BTTN	ThinkSystem 1600W -48V DC CRPS Hot-Swap Power Supply (PRC)	DC	2	No
4P57A78363	BU4H	ThinkSystem 1300W 230V/115V Platinum CRPS Hot-Swap Power Supply (PRC)	C13	2	Yes
4P57A82024	BU4G	ThinkSystem 1300W 230V/115V Platinum CRPS Hot-Swap Power Supply v2 (PRC)	C13	2	Yes
4P57A82018	BU4J	ThinkSystem 2700W 230V Platinum CRPS Hot-Swap Power Supply (PRC)	C19	2	No
4P57A82025	BU4K	ThinkSystem 2700W 230V Platinum CRPS Hot-Swap Power Supply v2 (PRC)	C19	2	No

The 1100W Platinum power supply is auto-sensing and supports both 110V AC (100-127V 50/60 Hz) and 220V AC (200-240V 50/60 Hz) power. All other power supplies only supports 220V AC power. For China customers, all power supplies support 240V DC.

Configuration notes:

- Installed power supplies must be identical wattage. For CRPS power supplies, part numbers cannot be mixed.
- Power supply options do not include a line cord. For server configurations, the inclusion of a power cord is model dependent. Configure-to-order models can be configured without a power cord if desired.

## Power supply LEDs

The supported hot-swap power supplies have the following LEDs:

- Power input LED:
  - Green: The power supply is connected to the AC power source
  - Off: The power supply is disconnected from the AC power source or a power problem has occurred
- Power output LED:
  - Green: The server is on and the power supply is working normally
  - Off: The server is powered off, or the power supply is not working properly
- Power supply error LED:
  - Off: The power supply is working normally
  - Yellow: The power supply has failed

**Note:** The SR850 V3 does not support Zero-output mode (also known as Standby mode) with power supplies.

## Power cords

Line cords and rack power cables with C13 connectors can be ordered as listed in the following table.

**110V customers:** If you plan to use the 1100W power supply with a 110V power source, select a power cable that is rated above 10A. Power cables that are rated at 10A or below are not supported with 110V power.

Table 40. Power cords

Part number	Feature code	Description
Rack cables - C13 to C14		
SL67B08593	BPHZ	0.5m, 10A/100-250V, C13 to C14 Jumper Cord
00Y3043	A4VP	1.0m, 10A/100-250V, C13 to IEC 320-C14 Rack Power Cable
4L67A08367	B0N5	1.0m, 13A/100-250V, C13 to C14 Jumper Cord
39Y7937	6201	1.5m, 10A/100-250V, C13 to IEC 320-C14 Rack Power Cable
4L67A08368	B0N6	1.5m, 13A/100-250V, C13 to C14 Jumper Cord
4L67A08365	B0N4	2.0m, 10A/100-250V, C13 to IEC 320-C14 Rack Power Cable
4L67A08369	6570	2.0m, 13A/100-250V, C13 to C14 Jumper Cord
4L67A08366	6311	2.8m, 10A/100-250V, C13 to IEC 320-C14 Rack Power Cable
4L67A08370	6400	2.8m, 13A/100-250V, C13 to C14 Jumper Cord
39Y7932	6263	4.3m, 10A/100-250V, C13 to IEC 320-C14 Rack Power Cable
4L67A08371	6583	4.3m, 13A/100-250V, C13 to C14 Rack Power Cable
Rack cables - C13 to C14 (Y-cable)		
00Y3046	A4VQ	1.345m, 2X C13 to C14 Jumper Cord, Rack Power Cable
00Y3047	A4VR	2.054m, 2X C13 to C14 Jumper Cord, Rack Power Cable
Rack cables - C13 to C20		
39Y7938	6204	2.8m, 10A/100-250V, C13 to IEC 320-C20 Rack Power Cable
Rack cables - C13 to C20 (Y-cable)		
47C2491	A3SW	1.2m, 16A/100-250V, 2 Short C13s to Short C20 Rack Power Cable
47C2492	A3SX	2.5m, 16A/100-250V, 2 Long C13s to Short C20 Rack Power Cable



Part number	Feature code	Description
47C2493	A3SY	2.8m, 16A/100-250V, 2 Short C13s to Long C20 Rack Power Cable
47C2494	A3SZ	4.1m, 16A/100-250V, 2 Long C13s to Long C20 Rack Power Cable
Line cords		
39Y7930	6222	2.8m, 10A/250V, C13 to IRAM 2073 (Argentina) Line Cord
81Y2384	6492	4.3m 10A/220V, C13 to IRAM 2073 (Argentina) Line Cord
39Y7924	6211	2.8m, 10A/250V, C13 to AS/NZ 3112 (Australia/NZ) Line Cord
81Y2383	6574	4.3m, 10A/230V, C13 to AS/NZS 3112 (Aus/NZ) Line Cord
69Y1988	6532	2.8m, 10A/250V, C13 to NBR 14136 (Brazil) Line Cord
81Y2387	6404	4.3m, 10A/250V, C13 - 2P+Gnd (Brazil) Line Cord
39Y7928	6210	2.8m, 220-240V, C13 to GB 2099.1 (China) Line Cord
81Y2378	6580	4.3m, 10A/220V, C13 to GB 2099.1 (China) Line Cord
39Y7918	6213	2.8m, 10A/250V, C13 to DK2-5a (Denmark) Line Cord
81Y2382	6575	4.3m, 10A/230V, C13 to DK2-5a (Denmark) Line Cord
39Y7917	6212	2.8m, 10A/230V, C13 to CEE7-VII (Europe) Line Cord
81Y2376	6572	4.3m, 10A/230V, C13 to CEE7-VII (Europe) Line Cord
39Y7927	6269	2.8m, 10A/250V, C13(2P+Gnd) (India) Line Cord
81Y2386	6567	4.3m, 10A/240V, C13 to IS 6538 (India) Line Cord
39Y7920	6218	2.8m, 10A/250V, C13 to SI 32 (Israel) Line Cord
81Y2381	6579	4.3m, 10A/230V, C13 to SI 32 (Israel) Line Cord
39Y7921	6217	2.8m, 220-240V, C13 to CEI 23-16 (Italy/Chile) Line Cord
81Y2380	6493	4.3m, 10A/230V, C13 to CEI 23-16 (Italy/Chile) Line Cord
46M2593	A1RE	2.8m, 12A/125V, C13 to JIS C-8303 (Japan) Line Cord
4L67A08362	6495	4.3m, 12A/200V, C13 to JIS C-8303 (Japan) Line Cord
39Y7926	6335	4.3m, 12A/100V, C13 to JIS C-8303 (Japan) Line Cord
39Y7922	6214	2.8m, 10A/250V, C13 to SABS 164 (S Africa) Line Cord
81Y2379	6576	4.3m, 10A/230V, C13 to SABS 164 (South Africa) Line Cord
39Y7925	6219	2.8m, 220-240V, C13 to KETI (S Korea) Line Cord
81Y2385	6494	4.3m, 12A/220V, C13 to KSC 8305 (S. Korea) Line Cord
39Y7919	6216	2.8m, 10A/250V, C13 to SEV 1011-S24507 (Swiss) Line Cord
81Y2390	6578	4.3m, 10A/230V, C13 to SEV 1011-S24507 (Sws) Line Cord
23R7158	6386	2.8m, 10A/125V, C13 to CNS 10917-3 (Taiwan) Line Cord
81Y2375	6317	2.8m, 10A/240V, C13 to CNS 10917-3 (Taiwan) Line Cord
81Y2374	6402	2.8m, 13A/125V, C13 to CNS 60799 (Taiwan) Line Cord
4L67A08363	AX8B	4.3m, 10A 125V, C13 to CNS 10917 (Taiwan) Line Cord
81Y2389	6531	4.3m, 10A/250V, C13 to 76 CNS 10917-3 (Taiwan) Line Cord
81Y2388	6530	4.3m, 13A/125V, C13 to CNS 10917 (Taiwan) Line Cord
39Y7923	6215	2.8m, 10A/250V, C13 to BS 1363/A (UK) Line Cord
81Y2377	6577	4.3m, 10A/230V, C13 to BS 1363/A (UK) Line Cord
90Y3016	6313	2.8m, 10A/120V, C13 to NEMA 5-15P (US) Line Cord
46M2592	A1RF	2.8m, 10A/250V, C13 to NEMA 6-15P Line Cord
00WH545	6401	2.8m, 13A/120V, C13 to NEMA 5-15P (US) Line Cord

Part number	Feature code	Description
4L67A08359	6370	4.3m, 10A/125V, C13 to NEMA 5-15P (US) Line Cord
4L67A08361	6373	4.3m, 10A/250V, C13 to NEMA 6-15P (US) Line Cord
4L67A08360	AX8A	4.3m, 13A/120V, C13 to NEMA 5-15P (US) Line Cord

### Power cords (C19 connectors)

Line cords and rack power cables with C19 connectors can be ordered as listed in the following table.

Table 41. Power cords (C19 connectors)

Part number	Feature code	Description
Rack cables		
4L67A86677	BPJ0	0.5m, 16A/100-250V, C19 to IEC 320-C20 Rack Power Cable
4L67A86678	B4L0	1.0m, 16A/100-250V, C19 to IEC 320-C20 Rack Power Cable
4L67A86679	B4L1	1.5m, 16A/100-250V, C19 to IEC 320-C20 Rack Power Cable
4L67A86680	B4L2	2.0m, 16A/100-250V, C19 to IEC 320-C20 Rack Power Cable
39Y7916	6252	2.5m, 16A/100-240V, C19 to IEC 320-C20 Rack Power Cable
4L67A86681	B4L3	4.3m, 16A/100-250V, C19 to IEC 320-C20 Rack Power Cable
Line cords		
40K9777	6276	4.3m, 220-240V, C19 to IRAM 2073 (Argentina) Line cord
40K9773	6284	4.3m, 220-240V, C19 to AS/NZS 3112 (Aus/NZ) Line cord
40K9775	6277	4.3m, 250V, C19 to NBR 14136 (Brazil) Line Cord
40K9774	6288	4.3m, 220-240V, C19 to GB2099.1 (China) Line cord
40K9769	6283	4.3m, 16A/230V, C19 to IEC 309-P+N+G (Den/Sws) Line Cord
40K9766	6279	4.3m, 220-240V, C19 to CEE7-VII (European) Line cord
40K9776	6285	4.3m, 220-240V, C19 to IS6538 (India) Line cord
40K9771	6282	4.3m, 220-240V, C19 to SI 32 (Israel) Line cord
40K9768	6281	4.3m, 220-240V, C19 to CEI 23-16 (Italy) Line cord
40K9770	6280	4.3m, 220-240V, C19 to SABS 164 (South Africa) Line cord
41Y9231	6289	4.3m, 15A/250V, C19 to KSC 8305 (S. Korea) Line Cord
81Y2391	6549	4.3m, 16A/230V, C19 to SEV 1011 (Sws) Line Cord
41Y9230	6287	4.3m, 16A/250V, C19 to CNS 10917-3 (Taiwan) Line Cord
40K9767	6278	4.3m, 220-240V, C19 to BS 1363/A w/13A fuse (UK) Line Cord
40K9772	6275	4.3m, 16A/208V, C19 to NEMA L6-20P (US) Line Cord
00D7197	A1NV	4.3m, 15A/250V, C19 to NEMA 6-15P (US) Line Cord

## Systems management

The SR850 V3 contains an integrated service processor, XClarity Controller 2 (XCC), which provides advanced control, monitoring, and alerting functions. The XCC2 is based on the AST2600 baseboard management controller (BMC) using a dual-core ARM Cortex A7 32-bit RISC service processor running at 1.2 GHz.

Topics in this section:

- [System I/O Board](#)

- [Local management](#)
- [System status with XClarity Mobile](#)
- [Remote management](#)
- [XCC2 Platinum](#)
- [Lenovo XClarity Provisioning Manager](#)
- [Lenovo XClarity Administrator](#)
- [Lenovo XClarity Integrators](#)
- [Lenovo XClarity Essentials](#)
- [Lenovo XClarity Energy Manager](#)
- [Lenovo Capacity Planner](#)

## System I/O Board

The SR850 V3 implements a separate System I/O Board that connects to the Processor Board. The location of the System I/O Board is shown in the [Components and connectors](#) section. The System I/O Board contains all the connectors visible at the rear of the server as shown in the following figure.

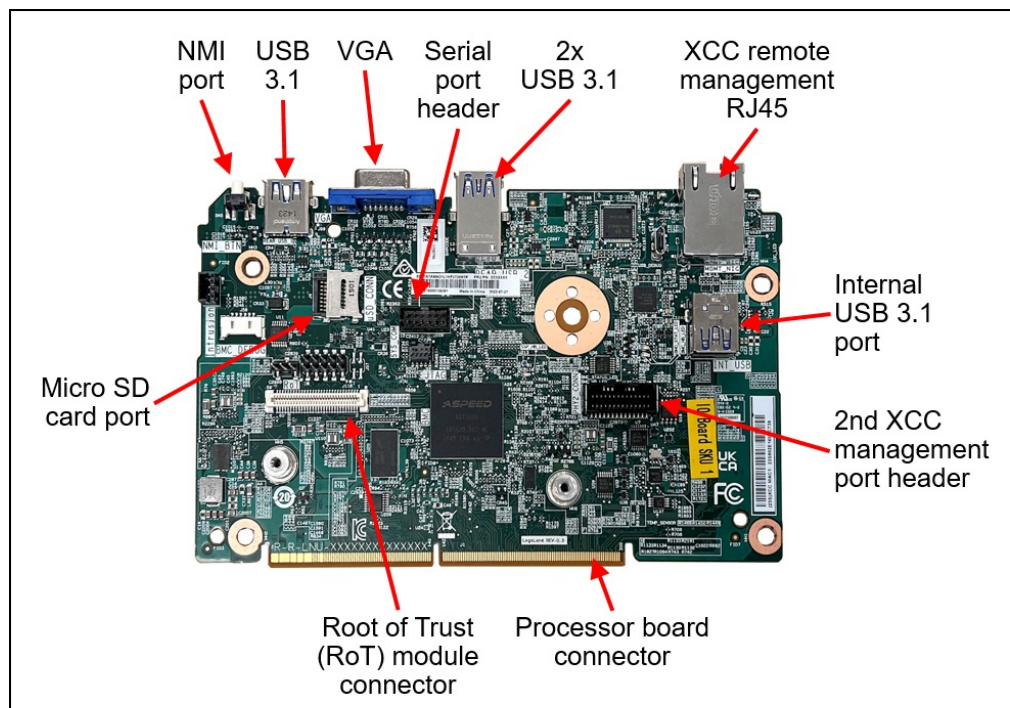

Figure 12. System I/O Board

The board also has the following components:

- XClarity Controller 2, implemented using the ASPEED AST2600 baseboard management controller (BMC).
- Root of Trust (RoT) module - a daughter card that implements Platform Firmware Resiliency (PFR) hardware Root of Trust (RoT) which enables the server to be NIST SP800-193 compliant. For more details about PFR, see the [Security](#) section.
- Connector to enable an additional redundant Ethernet connection to the XCC2 controller. The connector is used in conjunction with the ThinkSystem V3 Management NIC Adapter Kit (4XC7A85319). For details, see the [Remote management](#) section.
- Internal USB port - to allow the booting of an operating system from a USB key. The VMware ESXi preloads use this port for example. Preloads are described in the [Operating system support](#) section.

- MicroSD card port to enable the use of a MicroSD card for additional storage for use with the XCC2 controller. XCC2 can use the storage as a Remote Disc on Card (RDOC) device (up to 4GB of storage). It can also be used to store firmware updates (including N-1 firmware history) for ease of deployment.

**Tip:** Without a MicroSD card installed, the XCC2 controller will have 100MB of available RDOC storage.

Ordering information for the supported USB drive and Micro SD card are listed in the following table.

Table 42. Media for use with the System I/O Board

Part number	Feature code	Description
4X77A77065	BNWN	ThinkSystem USB 32GB USB 3.0 Flash Drive
4X77A77064	BNWP	ThinkSystem MicroSD 32GB Class 10 Flash Memory Card

### Local management

The server offers a front operator panel with key LED status indicators, as shown in the following figure.

**Tip:** The Network LED only shows network activity of an installed OCP network adapter. The LED shows activity from both OCP adapters if two are installed.

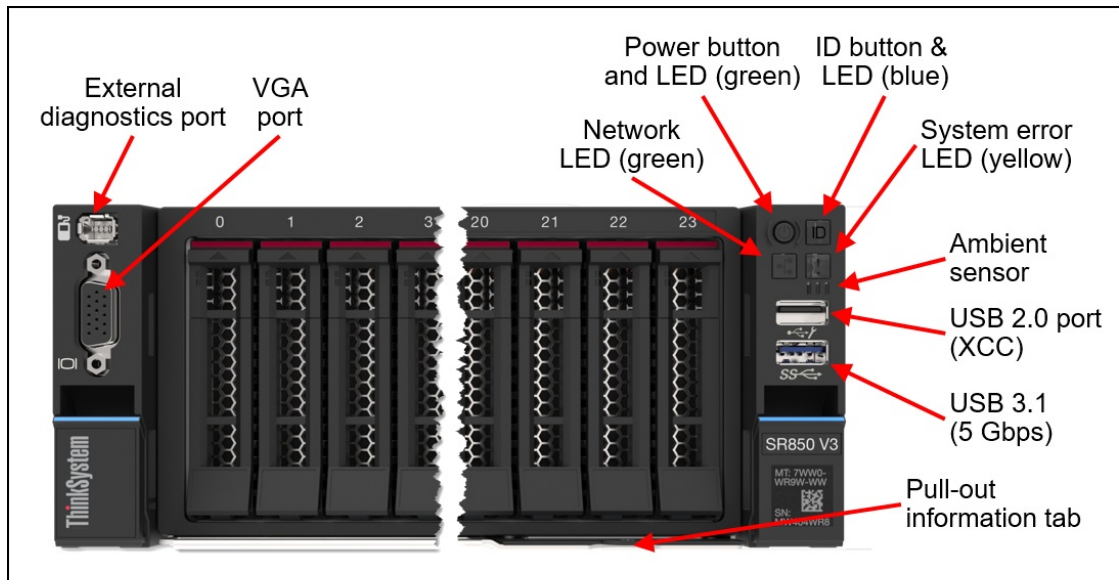

Figure 13. Front operator panel

### Light path diagnostics

The server offers light path diagnostics. If an environmental condition exceeds a threshold or if a system component fails, XCC lights LEDs inside the server to help you diagnose the problem and find the failing part. The server has fault LEDs next to the following components:

- Each memory DIMM
- Each drive bay
- Each power supply

### External Diagnostics Handset

The SR850 V3 has a port to connect an External Diagnostics Handset as described in the preceding section. The External Diagnostics Handset has the same functions as the Integrated Diagnostics Panel but has the advantages of not consuming space on the front of the server plus it can be shared among many servers in your data center. The handset has a magnet on the back of it to allow you to easily mount it on a convenient place on any rack cabinet.

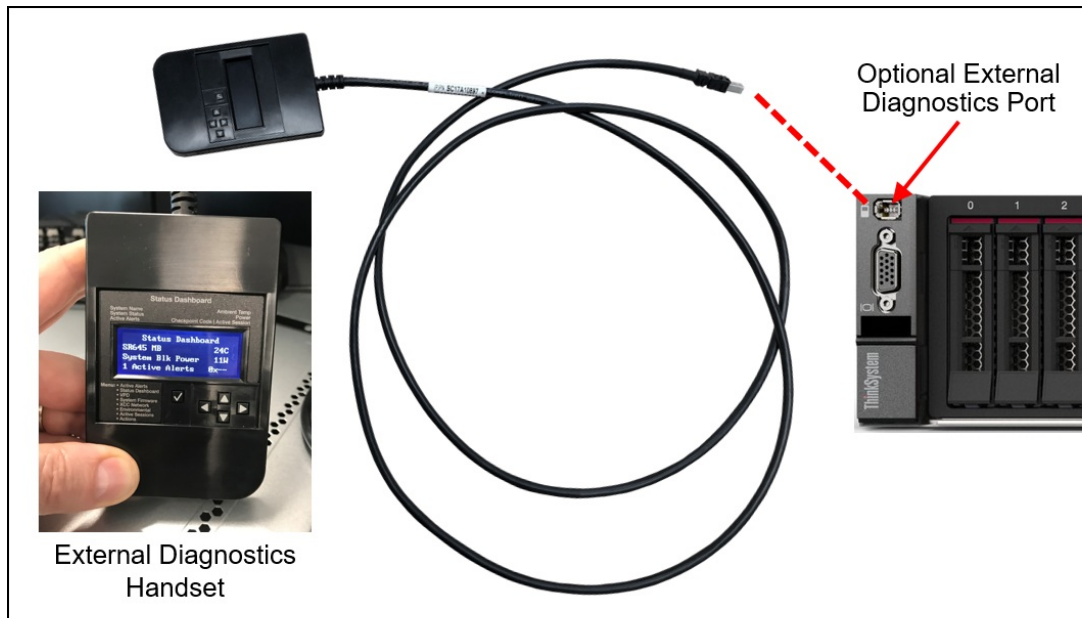

Figure 14. External Diagnostics Handset

Ordering information for the External Diagnostics Handset with is listed in the following table.

Table 43. External Diagnostics Handset ordering information

Part number	Feature code	Description
4TA7A64874	BEUX	ThinkSystem External Diagnostics Handset

### Information tab

The front of the server also houses an information pull-out tab (also known as the network access tag). See [Figure 2](#) for the location. A label on the tab shows the network information (MAC address and other data) to remotely access XClarity Controller.

### System status with XClarity Mobile

The XClarity Mobile app includes a tethering function where you can connect your Android or iOS device to the server via USB to see the status of the server.

The steps to connect the mobile device are as follows:

1. Enable USB Management on the server, by holding down the ID button for 3 seconds (or pressing the dedicated USB management button if one is present)
2. Connect the mobile device via a USB cable to the server's USB port with the management symbol 
3. In iOS or Android settings, enable Personal Hotspot or USB Tethering
4. Launch the Lenovo XClarity Mobile app

Once connected you can see the following information:

- Server status including error logs (read only, no login required)
- Server management functions (XClarity login credentials required)

## Remote management

The server offers a dedicated RJ45 port at the rear of the server for remote management via the XClarity Controller management processor. The port supports 10/100/1000 Mbps speeds.

Remote server management is provided through industry-standard interfaces:

- Intelligent Platform Management Interface (IPMI) Version 2.0
- Simple Network Management Protocol (SNMP) Version 3 (no SET commands; no SNMP v1)
- Common Information Model (CIM-XML)
- Representational State Transfer (REST) support
- Redfish support (DMTF compliant)
- Web browser - HTML 5-based browser interface (Java and ActiveX not required) using a responsive design (content optimized for device being used - laptop, tablet, phone) with NLS support

The SR850 V3 also supports the use of an OCP adapter that provides an additional redundant Ethernet connection to the XCC2 controller. Ordering information is listed in the following table.

Table 44. Redundant System Management Port Adapter

Part number	Feature code	Description	Maximum quantity
4XC7A85319	BTMQ	ThinkSystem V3 Management NIC Adapter Kit	1

The use of this adapter allows concurrent remote access using both the connection on the adapter and the onboard RJ45 remote management port provided by the server. The adapter and onboard port have separate IP addresses.

Configuration rules:

- In the SR850 V3, the ThinkSystem V3 Management NIC Adapter Kit is only supported in OCP slot 1

IPMI via the Ethernet port (IPMI over LAN) is supported, however it is disabled by default. For CTO orders you can specify whether you want the feature enabled or disabled in the factory, using the feature codes listed in the following table.

Table 45. IPMI-over-LAN settings

Feature code	Description
B7XZ	Disable IPMI-over-LAN (default)
B7Y0	Enable IPMI-over-LAN

## XCC2 Platinum

In the SR850 V3, XCC2 has the Platinum level of features built into the server. Compared to the XCC functions of ThinkSystem V2 and earlier systems, Platinum offers the same features as Enterprise and Advanced levels in ThinkSystem V2, plus additional features.

**DCSC tip:** Even though XCC2 Platinum is a standard feature of the SR850 V3, it does *not* appear in the list of feature codes for the configuration in DCSC.

XCC2 Platinum includes the following Enterprise and Advanced functions:

- Remotely viewing video with graphics resolutions up to 1600x1200 at 75 Hz with up to 23 bits per pixel, regardless of the system state
- Remotely accessing the server using the keyboard and mouse from a remote client
- International keyboard mapping support
- Syslog alerting
- Redirecting serial console via SSH
- Component replacement log (Maintenance History log)
- Access restriction (IP address blocking)
- Lenovo SED security key management
- Displaying graphics for real-time and historical power usage data and temperature
- Boot video capture and crash video capture
- Virtual console collaboration - Ability for up to 6 remote users to be log into the remote session simultaneously
- Remote console Java client
- Mapping the ISO and image files located on the local client as virtual drives for use by the server
- Mounting the remote ISO and image files via HTTPS, SFTP, CIFS, and NFS
- Power capping
- System utilization data and graphic view
- Single sign on with Lenovo XClarity Administrator
- Update firmware from a repository
- License for XClarity Energy Manager

XCC2 Platinum also includes the following features that are new to XCC2:

- System Guard - Monitor hardware inventory for unexpected component changes, and simply log the event or prevent booting
- Enterprise Strict Security mode - Enforces CNSA 1.0 level security
- Neighbor Group - Enables administrators to manage and synchronize configurations and firmware level across multiple servers

With XCC2 Platinum, for CTO orders, you can request that System Guard be enabled in the factory and the first configuration snapshot be recorded. To add this to an order, select feature code listed in the following table. The selection is made in the Security tab of the DCSC configurator.

Table 46. Enable System Guard in the factory (CTO orders)

Feature code	Description
BUT2	Install System Guard

For more information about System Guard, see [https://pubs.lenovo.com/xcc2/NN1ia\\_c\\_systemguard](https://pubs.lenovo.com/xcc2/NN1ia_c_systemguard)

## Lenovo XClarity Provisioning Manager

Lenovo XClarity Provisioning Manager (LXPM) is a UEFI-based application embedded in ThinkSystem servers and accessible via the F1 key during system boot.

LXPM provides the following functions:

- Graphical UEFI Setup
- System inventory information and VPD update
- System firmware updates (UEFI and XCC)
- RAID setup wizard
- OS installation wizard (including unattended OS installation)
- Diagnostics functions

## Lenovo XClarity Administrator

Lenovo XClarity Administrator is a centralized resource management solution designed to reduce complexity, speed response, and enhance the availability of Lenovo systems and solutions. It provides agent-free hardware management for ThinkSystem servers, in addition to ThinkServer, System x, and Flex System servers. The administration dashboard is based on HTML 5 and allows fast location of resources so tasks can be run quickly.

Because Lenovo XClarity Administrator does not require any agent software to be installed on the managed endpoints, there are no CPU cycles spent on agent execution, and no memory is used, which means that up to 1GB of RAM and 1 - 2% CPU usage is saved, compared to a typical managed system where an agent is required.

Lenovo XClarity Administrator is an optional software component for the SR850 V3. The software can be downloaded and used at no charge to discover and monitor the SR850 V3 and to manage firmware upgrades.

If software support is required for Lenovo XClarity Administrator, or premium features such as configuration management and operating system deployment are required, Lenovo XClarity Pro software subscription should be ordered. Lenovo XClarity Pro is licensed on a per managed system basis, that is, each managed Lenovo system requires a license.

The following table lists the Lenovo XClarity software license options.

Table 47. Lenovo XClarity Pro ordering information

Part number	Feature code	Description
00MT201	1339	Lenovo XClarity Pro, per Managed Endpoint w/1 Yr SW S&S
00MT202	1340	Lenovo XClarity Pro, per Managed Endpoint w/3 Yr SW S&S
00MT203	1341	Lenovo XClarity Pro, per Managed Endpoint w/5 Yr SW S&S
7S0X000HWW	SAYV	Lenovo XClarity Pro, per Managed Endpoint w/6 Yr SW S&S
7S0X000JWW	SAYW	Lenovo XClarity Pro, per Managed Endpoint w/7 Yr SW S&S



Lenovo XClarity Administrator offers the following standard features that are available at no charge:

- Auto-discovery and monitoring of Lenovo systems
- Firmware updates and compliance enforcement
- External alerts and notifications via SNMP traps, syslog remote logging, and e-mail
- Secure connections to managed endpoints
- NIST 800-131A or FIPS 140-2 compliant cryptographic standards between the management solution and managed endpoints
- Integration into existing higher-level management systems such as cloud automation and orchestration tools through REST APIs, providing extensive external visibility and control over hardware resources
- An intuitive, easy-to-use GUI
- Scripting with Windows PowerShell, providing command-line visibility and control over hardware resources

Lenovo XClarity Administrator offers the following premium features that require an optional Pro license:

- Pattern-based configuration management that allows to define configurations once and apply repeatedly without errors when deploying new servers or redeploying existing servers without disrupting the fabric
- Bare-metal deployment of operating systems and hypervisors to streamline infrastructure provisioning

For more information, refer to the Lenovo XClarity Administrator Product Guide:

<http://lenovopress.com/tips1200>

## **Lenovo XClarity Integrators**

Lenovo also offers software plug-in modules, Lenovo XClarity Integrators, to manage physical infrastructure from leading external virtualization management software tools including those from Microsoft and VMware.

These integrators are offered at no charge, however if software support is required, a Lenovo XClarity Pro software subscription license should be ordered.

Lenovo XClarity Integrators offer the following additional features:

- Ability to discover, manage, and monitor Lenovo server hardware from VMware vCenter or Microsoft System Center
- Deployment of firmware updates and configuration patterns to Lenovo x86 rack servers and Flex System from the virtualization management tool
- Non-disruptive server maintenance in clustered environments that reduces workload downtime by dynamically migrating workloads from affected hosts during rolling server updates or reboots
- Greater service level uptime and assurance in clustered environments during unplanned hardware events by dynamically triggering workload migration from impacted hosts when impending hardware failures are predicted

For more information about all the available Lenovo XClarity Integrators, see the Lenovo XClarity Administrator Product Guide: <https://lenovopress.com/tips1200-lenovo-xclarity-administrator>

## Lenovo XClarity Essentials

Lenovo offers the following XClarity Essentials software tools that can help you set up, use, and maintain the server at no additional cost:

- **Lenovo Essentials OneCLI**  
OneCLI is a collection of server management tools that uses a command line interface program to manage firmware, hardware, and operating systems. It provides functions to collect full system health information (including health status), configure system settings, and update system firmware and drivers.
- **Lenovo Essentials UpdateXpress**  
The UpdateXpress tool is a standalone GUI application for firmware and device driver updates that enables you to maintain your server firmware and device drivers up-to-date and help you avoid unnecessary server outages. The tool acquires and deploys individual updates and UpdateXpress System Packs (UXSPs) which are integration-tested bundles.
- **Lenovo Essentials Bootable Media Creator**  
The Bootable Media Creator (BOMC) tool is used to create bootable media for offline firmware update.

For more information and downloads, visit the Lenovo XClarity Essentials web page:  
<http://support.lenovo.com/us/en/documents/LNVO-center>

## Lenovo XClarity Energy Manager

Lenovo XClarity Energy Manager (LXEM) is a power and temperature management solution for data centers. It is an agent-free, web-based console that enables you to monitor and manage power consumption and temperature in your data center through the management console. It enables server density and data center capacity to be increased through the use of power capping.

LXEM is a licensed product. A single-node LXEM license is included with the XClarity Controller Platinum upgrade as described in the [XCC2 Platinum](#) section. If your server does not have the XCC Platinum upgrade, Energy Manager licenses can be ordered as shown in the following table.

Table 48. Lenovo XClarity Energy Manager

Part number	Description
4L40E51621	Lenovo XClarity Energy Manager Node License (1 license needed per server)

For more information about XClarity Energy Manager, see the following resources:

- **Lenovo Support page:**  
<https://datacentersupport.lenovo.com/us/en/solutions/Invo-lxem>
- **User Guide for XClarity Energy Manager:**  
<https://pubs.lenovo.com/lxem/>

## Lenovo Capacity Planner

Lenovo Capacity Planner is a power consumption evaluation tool that enhances data center planning by enabling IT administrators and pre-sales professionals to understand various power characteristics of racks, servers, and other devices. Capacity Planner can dynamically calculate the power consumption, current, British Thermal Unit (BTU), and volt-ampere (VA) rating at the rack level, improving the planning efficiency for large scale deployments.

For more information, refer to the Capacity Planner web page:  
<http://datacentersupport.lenovo.com/us/en/solutions/Invo-lcp>

## Security

Topics in this section:

- [Security features](#)
- [Platform Firmware Resiliency - Lenovo ThinkShield](#)
- [Intel Transparent Supply Chain](#)
- [Security standards](#)

### Security features

The SR850 V3 server offers the following electronic security features:

- Secure Boot function of the Intel Xeon processor
- Support for Platform Firmware Resiliency (PFR) hardware Root of Trust (RoT) - see the [Platform Firmware Resiliency](#) section
- Firmware signature processes compliant with FIPS and NIST requirements
- System Guard (part of [XCC2 Platinum](#)) - Proactive monitoring of hardware inventory for unexpected component changes
- Administrator and power-on password
- Integrated Trusted Platform Module (TPM) supporting TPM 2.0
- Self-encrypting drives (SEDs) with support for enterprise key managers - see the [SED encryption key management](#) section

The server is NIST SP 800-147B compliant.

The SR850 V3 server also offers the following physical security features:

- Chassis intrusion switch (standard on some models, otherwise available as a field upgrade)
- Optional lockable front security bezel

The dimensions of the security bezel are:

- Width: 437 mm (17.2 in.)
- Height: 87 mm (3.4 in.)
- Width: 23 mm (0.9 in.)

The following table lists the security options for the SR850 V3.

Table 49. Security options

Part number	Feature code	Description
4M27A11826	BCPG	ThinkSystem SR860 V3/SR850 V3/SR850 V2 Intrusion Cable Kit
4XH7A09886	B8M2	ThinkSystem V2 2U Security Bezel Option Kit

For SED drives and IBM Security Key Lifecycle Manager support see the [SED encryption key management with ISKLM](#) section.

### Platform Firmware Resiliency - Lenovo ThinkShield

Lenovo's ThinkShield Security is a transparent and comprehensive approach to security that extends to all dimensions of our data center products: from development, to supply chain, and through the entire product lifecycle.

The ThinkSystem SR850 V3 includes Platform Firmware Resiliency (PFR) hardware Root of Trust (RoT) which enables the system to be NIST SP800-193 compliant. This offering further enhances key platform subsystem protections against unauthorized firmware updates and corruption, to restore firmware to an integral state, and to closely monitor firmware for possible compromise from cyber-attacks.

PFR operates upon the following server components:

- UEFI image – the low-level server firmware that connects the operating system to the server hardware
- XCC image – the management “engine” software that controls and reports on the server status separate from the server operating system
- FPGA image – the code that runs the server’s lowest level hardware controller on the motherboard

The Lenovo Platform Root of Trust Hardware performs the following three main functions:

- Detection – Measures the firmware and updates for authenticity
- Recovery – Recovers a corrupted image to a known-safe image
- Protection – Monitors the system to ensure the known-good firmware is not maliciously written

These enhanced protection capabilities are implemented using a dedicated, discrete security processor whose implementation has been rigorously validated by leading third-party security firms. Security evaluation results and design details are available for customer review – providing unprecedented transparency and assurance.

The SR850 V3 includes support for Secure Boot, a UEFI firmware security feature developed by the UEFI Consortium that ensures only immutable and signed software are loaded during the boot time. The use of Secure Boot helps prevent malicious code from being loaded and helps prevent attacks, such as the installation of rootkits. Lenovo offers the capability to enable secure boot in the factory, to ensure end-to-end protection.

The following table lists the relevant feature code(s).

Table 50. Secure Boot options

Part number	Feature code	Description	Purpose
CTO only	BPKQ	TPM 2.0 with Secure Boot	Configure the system in the factory with Secure Boot enabled.

### Intel Transparent Supply Chain

Add a layer of protection in your data center and have peace of mind that the server hardware you bring into it is safe authentic and with documented, testable, and provable origin.

Lenovo has one of the world’s best supply chains, as ranked by Gartner Group, backed by extensive and mature supply chain security programs that exceed industry norms and US Government standards. Now we are the first Tier 1 manufacturer to offer Intel® Transparent Supply Chain in partnership with Intel, offering you an unprecedented degree of supply chain transparency and assurance.

To enable Intel Transparent Supply Chain for the Intel-based servers in your order, add the following feature code in the [DCSC configurator](#), under the Security tab.

Table 51. Intel Transparent Supply Chain ordering information

Feature code	Description
BB0P	Intel Transparent Supply Chain

For more information on this offering, see the paper *Introduction to Intel Transparent Supply Chain on Lenovo ThinkSystem Servers*, available from <https://lenovopress.com/lp1434-introduction-to-intel-transparent-supply-chain-on-thinksystem-servers>.

## Security standards

The SR850 V3 supports the following security standards and capabilities:

- **Industry Standard Security Capabilities**

- Intel CPU Enablement
  - AES-NI (Advanced Encryption Standard New Instructions)
  - CbT (Converged Boot Guard and Trusted Execution Technology)
  - CET (Control flow Enforcement Technology)
  - Hardware-based side channel attack resilience enhancements
  - MKTME/TME (Multi-Key Total Memory Encryption)
  - SGX (Software Guard eXtensions)
  - SGX-TEM (Trusted Environment Mode)
  - TDX (Trust Domain Extensions)
  - TXT (Trusted eXecution Technology)
  - VT (Virtualization Technology)
  - XD (eXecute Disable)
- Microsoft Windows Security Enablement
  - Credential Guard
  - Device Guard
  - Host Guardian Service
- TCG (Trusted Computing Group) TPM (Trusted Platform Module) 2.0
- UEFI (Unified Extensible Firmware Interface) Forum Secure Boot

- **Hardware Root of Trust and Security**

- Independent security subsystem providing platform-wide NIST SP800-193 compliant Platform Firmware Resilience (PFR)
- Management domain RoT supplemented by the Secure Boot features of XCC

- **Platform Security**

- Boot and run-time firmware integrity monitoring with rollback to known-good firmware (e.g., “self-healing”)
- Non-volatile storage bus security monitoring and filtering
- Resilient firmware implementation, such as to detect and defeat unauthorized flash writes or SMM (System Management Mode) memory incursions
- Patented IPMI KCS channel privileged access authorization (USPTO Patent# 11,256,810)
- Host and management domain authorization, including integration with CyberArk for enterprise password management
- KMIP (Key Management Interoperability Protocol) compliant, including support for IBM SKLM and Thales KeySecure

- Reduced “out of box” attack surface
- Configurable network services
- FIPS 140-3 (in progress) validated cryptography for XCC
- CNSA Suite 1.0 Quantum-resistant cryptography for XCC
- Lenovo System Guard

For more information on platform security, see the paper “How to Harden the Security of your ThinkSystem Server and Management Applications” available from <https://lenovopress.com/lp1260-how-to-harden-the-security-of-your-thinksystem-server>.

- **Standards Compliance and/or Support**

- NIST SP800-131A rev 2 “Transitioning the Use of Cryptographic Algorithms and Key Lengths”
- NIST SP800-147B “BIOS Protection Guidelines for Servers”
- NIST SP800-193 “Platform Firmware Resiliency Guidelines”
- ISO/IEC 11889 “Trusted Platform Module Library”
- Common Criteria TCG Protection Profile for “PC Client Specific TPM 2.0”
- European Union Commission Regulation 2019/424 (“ErP Lot 9”) “Ecodesign Requirements for Servers and Data Storage Products” Secure Data Deletion
- Optional FIPS 140-2 validated Self-Encrypting Disks (SEDs) with external KMIP-based key management

- **Product and Supply Chain Security**

- Suppliers validated through Lenovo’s Trusted Supplier Program
- Developed in accordance with Lenovo’s Secure Development Lifecycle (LSDL)
- Continuous firmware security validation through automated testing, including static code analysis, dynamic network and web vulnerability testing, software composition analysis, and subsystem-specific testing, such as UEFI security configuration validation
- Ongoing security reviews by US-based security experts, with attestation letters available from our third-party security partners
- Digitally signed firmware, stored and built on US-based infrastructure and signed on US-based Hardware Security Modules (HSMs)
- Manufacturing transparency via Intel Transparent Supply Chain (for details, see <https://lenovopress.com/lp1434-introduction-to-intel-transparent-supply-chain-on-lenovo-thinksystem-servers>)
- TAA (Trade Agreements Act) compliant manufacturing, by default in Mexico for North American markets with additional US and EU manufacturing options
- US 2019 NDAA (National Defense Authorization Act) Section 889 compliant

## Rack installation

The following table lists the rack installation options that are available for the server.

Table 52. Rack installation options

Option	Feature Code	Description
4XF7A86615	BT6H	ThinkSystem SR850 V3 Slide Rail
4XF7A86617	BT6J	ThinkSystem SR850 V3/SR860 V3 Cable Management Arm

The following table summarizes the rail kit features and specifications.

Table 53. Rail kit features and specifications summary

Feature	ThinkSystem SR850 V3 Slide Rail
Part number	4XF7A86615
Rail type	Full-out slide rail (ball bearing)
Toolless installation	Yes
Cable Management Arm (CMA) support	Optional (4XF7A86617)
In-rack server maintenance	Yes
1U PDU support	Yes
0U PDU support	Limited*
Rack type	Four-post IBM and Lenovo standard rack, complying with the IEC standard
Mounting holes	Square (9.5mm), round (7.1mm)
Mounting flange thickness	2.0-3.3 mm (0.08 - 0.13 inches)
Distance between front and rear mounting flanges	610-813 mm (24-32 inches)
Rail length***	918 mm (36.1 inches)

\* For 0U PDU support, the rack must be at least 1100 mm (43.31 in.) deep without the CMA, or at least 1200 mm (47.24 in.) deep if the CMA is used.

\*\*\* Measured when mounted on the rack, from the front surface of the front mounting flange to the rear most point of the rail.

For additional information, see the document *Rail and supported rack specifications for ThinkSystem servers*, available from:

<https://www.lenovo.com/us/en/resources/data-center-solutions/brochures/thinksystem-rail-support-matrix/>

## Operating system support

The server supports the following operating systems:

For a complete list of supported, certified and tested operating systems, plus additional details and links to relevant web sites, see the Operating System Interoperability Guide:

<https://lenovopress.lenovo.com/osig#servers=sr850-v3-7d97-7d96>

For configure-to-order configurations, the server can be preloaded with VMware ESXi installed on M.2 cards or 7mm drives. Ordering information is listed in the following table.

Table 54. VMware ESXi preload

Feature code	Description
BMEY	VMware ESXi 7.0 U3 (Factory Installed)
BQ8S	VMware ESXi 8.0 U1 (Factory Installed)
BYC7	VMware ESXi 8.0 U2 (Factory Installed)

Configuration rule:

- An ESXi preload cannot be selected if the configuration includes an NVIDIA GPU (ESXi preload cannot include the NVIDIA driver)

You can download supported VMware vSphere hypervisor images from the following web page and load it on the M.2 drives or 7mm drives using the instructions provided:

[https://vmware.lenovo.com/content/custom\\_iso/](https://vmware.lenovo.com/content/custom_iso/)

## Physical and electrical specifications

The SR850 V3 has the following overall physical dimensions, excluding components that extend outside the standard chassis, such as EIA flanges, front security bezel (if any), and power supply handles:

- Width: 447 mm (17.6 inches)
- Height: 87 mm (3.4 inches)
- Depth: 902 mm (35.5 inches)

The following table lists the detailed dimensions. See the figure below for the definition of each dimension.



Table 55. Detailed dimensions

Dimension	Description
482 mm	$X_a$ = Width, to the outsides of the front EIA flanges
435 mm	$X_b$ = Width, to the rack rail mating surfaces
447 mm	$X_c$ = Width, to the outer most chassis body feature
87 mm	$Y_a$ = Height, from the bottom of chassis to the top of the chassis
826 mm	$Z_a$ = Depth, from the rack flange mating surface to the rearmost I/O port surface
865 mm	$Z_b$ = Depth, from the rack flange mating surface to the rearmost feature of the chassis body
869 mm ( $\leq 1100W$ ) 897 mm (1800W) 923 mm (2400W)	$Z_c$ = Depth, from the rack flange mating surface to the rearmost feature such as power supply handle
37 mm	$Z_d$ = Depth, from the forwardmost feature on front of EIA flange to the rack flange mating surface
47 mm	$Z_e$ = Depth, from the front of security bezel (if applicable) or forwardmost feature to the rack flange mating surface

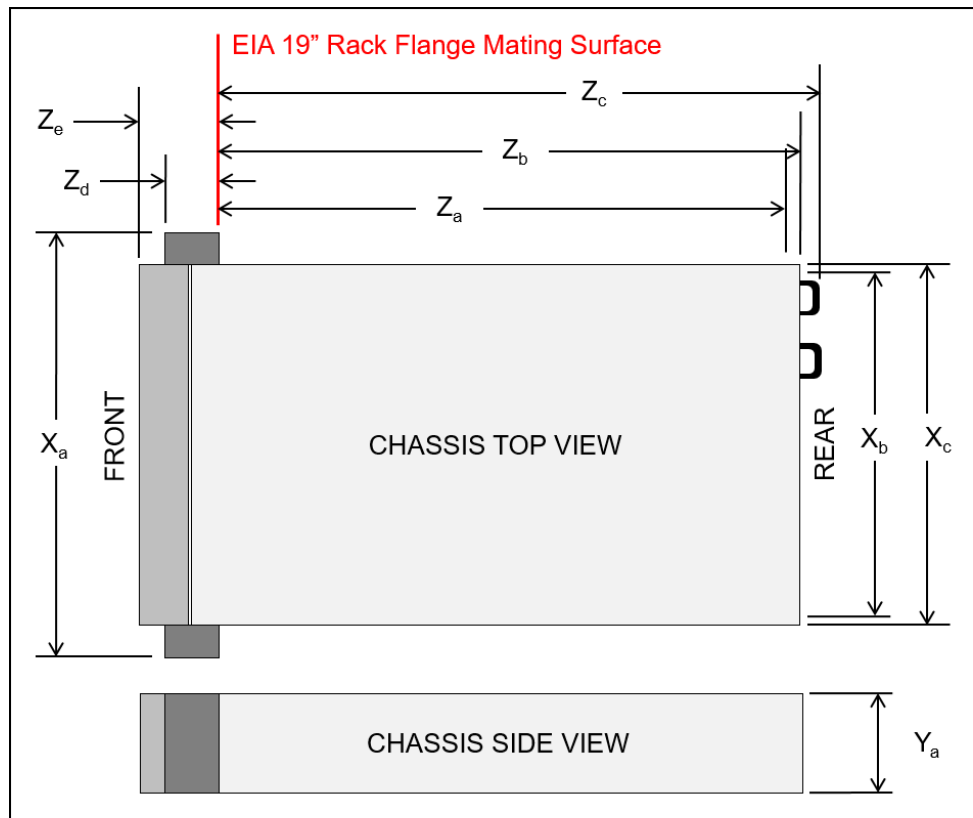

Figure 15. Server dimensions

The shipping dimensions (cardboard packaging) of the SR850 V3 are as follows:

- Width: 590 mm (23.2 inches)
- Height: 282 mm (11.1 inches)
- Depth: 1159 mm (45.6 inches)

The server has the following weight:

- Base configuration:
- Maximum weight: 36.7 kg (80.9 lb)

Electrical specifications for AC input power supplies:

- Input voltage:
  - 100 to 127 (nominal) Vac, 50 Hz or 60 Hz
  - 200 to 240 (nominal) Vac, 50 Hz or 60 Hz
  - 180 to 300 Vdc (China only)
- Inlet current: See the following table.

Table 56. Maximum inlet current

Part number	Description	100V AC	200V AC	220V AC	240V DC
<b>AC input power - 80 PLUS Titanium efficiency</b>					
4P57A72666	ThinkSystem 1100W 230V Titanium Hot-Swap Gen2 Power Supply	No support	5.9A	5.3A	5A
4P57A78359	ThinkSystem 1800W 230V Titanium Hot-Swap Gen2 Power Supply	No support	9.7A	8.7A	8.3A
4P57A72667	ThinkSystem 2600W 230V Titanium Hot-Swap Gen2 Power Supply	No support	13.2A	13A	11.9A
<b>AC input power - 80 PLUS Platinum efficiency</b>					
4P57A72671	ThinkSystem 1100W 230V/115V Platinum Hot-Swap Gen2 Power Supply v3	12A	6A	5.4A	5.1A
4P57A26294	ThinkSystem 1800W 230V Platinum Hot-Swap Gen2 Power Supply v2	No support	10A	9.1A	9A
4P57A26295	ThinkSystem 2400W 230V Platinum Hot-Swap Gen2 Power Supply	No support	14A	12.6A	12A

Electrical specifications for DC input power supply:

- Input voltage: -48 to -60 Vdc
- Inlet current (1100W power supply): 26 A

## Operating environment

The SR850 V3 server complies with ASHRAE Class A2 specifications with most configurations, and depending on the hardware configuration, also complies with ASHRAE Class A3 and Class A4 specifications.

Depending on the hardware configuration, the SR850 V3 server also complies with ASHRAE Class H1 specification. System performance may be impacted when operating temperature is outside ASHRAE H1 specification.

Topics in this section:

- [Temperature and humidity](#)
- [Ambient temperature requirements](#)
- [Acoustical noise emissions](#)
- [Shock and vibration](#)
- [Particulate contamination](#)

## Temperature and humidity

The server is supported in the following environment:

- Air temperature:
  - Operating
    - ASHRAE Class A2: 10°C to 35°C (50°F to 95°F); the maximum ambient temperature decreases by 1°C for every 300 m (984 ft) increase in altitude above 900 m (2,953 ft).
    - ASHRAE Class A3: 5°C to 40°C (41°F to 104°F); the maximum ambient temperature decreases by 1°C for every 175 m (574 ft) increase in altitude above 900 m (2,953 ft).
    - ASHRAE Class A4: 5°C to 45°C (41°F to 113°F); the maximum ambient temperature decreases by 1°C for every 125 m (410 ft) increase in altitude above 900 m (2,953 ft).
    - ASHRAE Class H1: 5 °C to 25 °C (41 °F to 77 °F); Decrease the maximum ambient temperature by 1°C for every 500 m (1640 ft) increase in altitude above 900 m (2,953 ft).
  - Server off: 5°C to 45°C (41°F to 113°F)
  - Shipment/storage: -40°C to 60°C (-40°F to 140°F)
- Maximum altitude: 3,050 m (10,000 ft)
- Relative Humidity (non-condensing):
  - Operating
    - ASHRAE Class A2: 8% to 80%; maximum dew point: 21°C (70°F)
    - ASHRAE Class A3: 8% to 85%; maximum dew point: 24°C (75°F)
    - ASHRAE Class A4: 8% to 90%; maximum dew point: 24°C (75°F)
    - ASHRAE Class H1: 8% to 80%; Maximum dew point: 17°C (63°F)
  - Shipment/storage: 8% to 90%

## Ambient temperature requirements

Adjust ambient temperature when specific components are installed:

- Keep ambient temperature to 45°C or lower when one or more of the following components are installed.
  - Processor with TDP less than or equal to 165W
  - Memory module with 64 GB or lower capacity
- Keep ambient temperature to 35°C or lower when one or more of the following components are installed.
  - Processors with TDP greater than 165W and less than or equal to 250W
  - ConnectX-7 NDR200 QSFP 2-port adapter without Active Optical Cable
  - ConnectX-7 NDR400 QSFP 1-port adapter without Active Optical Cable
- Keep ambient temperature to 30°C or lower when one or more of the following components are installed.
  - Processors with TDP greater than 250W
  - Single-wide GPU adapter and processor with TDP 270W <sup>1</sup>
  - Memory module with capacity 96 GB or 128 GB <sup>2</sup>
  - ConnectX-6 Dx 100GbE QSFP56 2-port adapter with Active Optical Cable <sup>2</sup>
  - ConnectX-6 HDR/200GbE QSFP56 2-port adapter with Active Optical Cable <sup>2</sup>
  - ConnectX-7 NDR200 QSFP 2-port adapter with Active Optical Cable <sup>2</sup>
  - ConnectX-7 NDR400 QSFP 1-port adapter with Active Optical Cable <sup>2</sup>
- Keep ambient temperature to 28°C or lower when single-wide GPU adapter and processor with TDP

165W are installed.<sup>3</sup>

- Keep ambient temperature to 25°C or lower when one or more of the following components are installed.
  - Double-wide GPU adapter and processor with TDP 165W<sup>3</sup>
  - Memory module with capacity 256 GB<sup>1</sup>

#### Note

- <sup>1</sup> The maximum number of supported 2.5-inch drives is eight.
- <sup>2</sup> The maximum number of supported 2.5-inch drives is sixteen.
- <sup>3</sup> The maximum number of supported 2.5-inch drives is four.

### Acoustical noise emissions

The server has the following acoustic noise emissions declaration:

- Sound power level ( $L_{WAd}$ )
  - Idling:
    - Typical: 6.8 Bel
    - Storage rich: 6.8 Bel
    - GPU: 7.8 Bel
  - Operating:
    - Typical: 8.0 Bel
    - Storage rich: 8.0 Bel
    - GPU: 9.0 Bel
- Sound pressure level ( $L_{pAm}$ ):
  - Idling:
    - Typical: 52.3 dBA
    - Storage rich: 52.3 dBA
    - GPU: 61.9 dBA
  - Operating:
    - Typical: 64.9 dBA
    - Storage: 64.9 dBA
    - GPU: 72.1 dBA

#### Notes:

- These sound levels were measured in controlled acoustical environments according to procedures specified by ISO7779 and are reported in accordance with ISO 9296.
- The declared acoustic sound levels are based on the specified configurations, which may change depending on configuration/conditions.
  - Typical configuration: four 205W CPUs, thirty-two 64GB RDIMMs, eight SAS HDDs, RAID 940-8i, Intel X710-T2L 10GBASE-T 2-port OCP, two 1100W PSUs.
  - GPU configuration: four 165W CPUs, two A100 GPUs, thirty-two 64GB RDIMMs, twenty-four SAS HDDs, RAID 940-16i, Intel X710-T2L 10GBASE-T 2-port OCP, two 1800W PSUs.
  - Storage rich configuration: four 205W CPUs, thirty-two 64GB RDIMMs, twenty-four SAS HDDs, RAID 940-8i, Intel X710-T2L 10GBASE-T 2-port OCP, two 2600W PSUs.
- Government regulations (such as those prescribed by OSHA or European Community Directives) may govern noise level exposure in the workplace and may apply to you and your server installation. The actual sound pressure levels in your installation depend upon a variety of factors, including the number of racks in the installation; the size, materials, and configuration of the room; the noise levels from other equipment; the room ambient temperature, and employee's location in relation to the equipment. Further, compliance with such government regulations depends on a variety of additional factors, including the duration of employees' exposure and whether employees wear hearing protection. Lenovo recommends that you consult with qualified experts in this field to determine whether you are in compliance with the applicable regulations.

## Shock and vibration

The server has the following vibration and shock limits:

- Vibration:
  - Operating: 0.21 G rms at 5 Hz to 500 Hz for 15 minutes across 3 axes
  - Non-operating: 1.04 G rms at 2 Hz to 200 Hz for 15 minutes across 6 surfaces
- Shock:
  - Operating: 15 G for 3 milliseconds in each direction (positive and negative X, Y, and Z axes)
  - Non-operating:
    - 23 kg - 31 kg: 35 G for 152 in./sec velocity change across 6 surfaces
    - 32 kg - 68 kg: 35 G for 136 in./sec velocity change across 6 surfaces

## Particulate contamination

Airborne particulates (including metal flakes or particles) and reactive gases acting alone or in combination with other environmental factors such as humidity or temperature might damage the system that might cause the system to malfunction or stop working altogether.

The following specifications indicate the limits of particulates that the system can tolerate:

- Reactive gases:
  - The copper reactivity level shall be less than 200 Angstroms per month (Å/month)
  - The silver reactivity level shall be less than 200 Å/month
- Airborne particulates:
  - The room air should be continuously filtered with MERV 8 filters.
  - Air entering a data center should be filtered with MERV 11 or preferably MERV 13 filters.
  - The deliquescent relative humidity of the particulate contamination should be more than 60% RH
  - Environment must be free of zinc whiskers

For additional information, see the Specifications section of the documentation for the server, available from the Lenovo Documents site, <https://pubs.lenovo.com/>

## Warranty and Support

The SR850 V3 has a 1-year or 3-year warranty based on the machine type of the system:

- 7D97 - 1-year warranty
- 7D96 - 3-year warranty
- 7D98 - SAP HANA configurations with 3-year warranty

The standard warranty terms are customer-replaceable unit (CRU) and onsite (for field-replaceable units FRUs only) with standard call center support during normal business hours and 9x5 Next Business Day Parts Delivered.

Lenovo's additional support services provide a sophisticated, unified support structure for your data center, with an experience consistently ranked number one in customer satisfaction worldwide. Available offerings include:

- **Premier Support**

Premier Support provides a Lenovo-owned customer experience and delivers direct access to technicians skilled in hardware, software, and advanced troubleshooting, in addition to the following:

- Direct technician-to-technician access through a dedicated phone line
- 24x7x365 remote support
- Single point of contact service
- End to end case management
- Third-party collaborative software support
- Online case tools and live chat support
- On-demand remote system analysis

- **Warranty Upgrade (Preconfigured Support)**

Services are available to meet the on-site response time targets that match the criticality of your systems.

- 3, 4, or 5 years of service coverage
- 1-year or 2-year post-warranty extensions
- **Foundation Service:** 9x5 service coverage with next business day onsite response. YourDrive YourData is an optional extra (see below).
- **Essential Service:** 24x7 service coverage with 4-hour onsite response or 24-hour committed repair (available only in select markets). Bundled with YourDrive YourData.
- **Advanced Service:** 24x7 service coverage with 2-hour onsite response or 6-hour committed repair (available only in select markets). Bundled with YourDrive YourData.

- **Managed Services**

Lenovo Managed Services provides continuous 24x7 remote monitoring (plus 24x7 call center availability) and proactive management of your data center using state-of-the-art tools, systems, and practices by a team of highly skilled and experienced Lenovo services professionals.

Quarterly reviews check error logs, verify firmware & OS device driver levels, and software as needed. We'll also maintain records of latest patches, critical updates, and firmware levels, to ensure you systems are providing business value through optimized performance.

- **Technical Account Management (TAM)**

A Lenovo Technical Account Manager helps you optimize the operation of your data center based on a deep understanding of your business. You gain direct access to your Lenovo TAM, who serves as your single point of contact to expedite service requests, provide status updates, and furnish reports to track incidents over time. In addition, your TAM will help proactively make service recommendations and manage your service relationship with Lenovo to make certain your needs are met.

- **Enterprise Server Software Support**

Enterprise Software Support is an additional support service providing customers with software support on Microsoft, Red Hat, SUSE, and VMware applications and systems. Around the clock availability for critical problems plus unlimited calls and incidents helps customers address challenges fast, without incremental costs. Support staff can answer troubleshooting and diagnostic questions, address product comparability and interoperability issues, isolate causes of problems, report defects to software vendors, and more.

- **YourDrive YourData**

Lenovo's YourDrive YourData is a multi-drive retention offering that ensures your data is always under your control, regardless of the number of drives that are installed in your Lenovo server. In the unlikely event of a drive failure, you retain possession of your drive while Lenovo replaces the failed drive part. Your data stays safely on your premises, in your hands. The YourDrive YourData service can be purchased in convenient bundles and is optional with Foundation Service. It is bundled with Essential Service and Advanced Service.

- **Health Check**

Having a trusted partner who can perform regular and detailed health checks is central to maintaining efficiency and ensuring that your systems and business are always running at their best. Health Check supports Lenovo-branded server, storage, and networking devices, as well as select Lenovo-supported products from other vendors that are sold by Lenovo or a Lenovo-Authorized Reseller.

Examples of region-specific warranty terms are second or longer business day parts delivery or parts-only base warranty.

If warranty terms and conditions include onsite labor for repair or replacement of parts, Lenovo will dispatch a service technician to the customer site to perform the replacement. Onsite labor under base warranty is limited to labor for replacement of parts that have been determined to be field-replaceable units (FRUs). Parts that are determined to be customer-replaceable units (CRUs) do not include onsite labor under base warranty.

If warranty terms include parts-only base warranty, Lenovo is responsible for delivering only replacement parts that are under base warranty (including FRUs) that will be sent to a requested location for self-service. Parts-only service does not include a service technician being dispatched onsite. Parts must be changed at customer's own cost and labor and defective parts must be returned following the instructions supplied with the spare parts.

Lenovo Service offerings are region-specific. Not all preconfigured support and upgrade options are available in every region. For information about Lenovo service upgrade offerings that are available in your region, refer to the following resources:

- Service part numbers in Lenovo Data Center Solution Configurator (DCSC):  
<http://dcsc.lenovo.com/#/services>
- Lenovo Services Availability Locator  
<http://lenovolocator.com/>

For service definitions, region-specific details, and service limitations, please refer to the following documents:

- Lenovo Statement of Limited Warranty for Infrastructure Solutions Group (ISG) Servers and System Storage  
<http://pcsupport.lenovo.com/us/en/solutions/ht503310>
- Lenovo Data Center Services Agreement  
<http://support.lenovo.com/us/en/solutions/ht116628>

## Services

Lenovo Services is a dedicated partner to your success. Our goal is to reduce your capital outlays, mitigate your IT risks, and accelerate your time to productivity.

**Note:** Some service options may not be available in all markets or regions. For more information, go to <https://www.lenovo.com/services>. For information about Lenovo service upgrade offerings that are available in your region, contact your local Lenovo sales representative or business partner.

Here's a more in-depth look at what we can do for you:

- **Asset Recovery Services**

Asset Recovery Services (ARS) helps customers recover the maximum value from their end-of-life equipment in a cost-effective and secure way. On top of simplifying the transition from old to new equipment, ARS mitigates environmental and data security risks associated with data center equipment disposal. Lenovo ARS is a cash-back solution for equipment based on its remaining market value, yielding maximum value from aging assets and lowering total cost of ownership for your customers. For more information, see the ARS page, <https://lenovopress.com/lp1266-reduce-e-waste-and-grow-your-bottom-line-with-lenovo-ars>.

- **Assessment Services**

An Assessment helps solve your IT challenges through an onsite, multi-day session with a Lenovo technology expert. We perform a tools-based assessment which provides a comprehensive and thorough review of a company's environment and technology systems. In addition to the technology based functional requirements, the consultant also discusses and records the non-functional business requirements, challenges, and constraints. Assessments help organizations like yours, no matter how large or small, get a better return on your IT investment and overcome challenges in the ever-changing technology landscape.

- **Design Services**

Professional Services consultants perform infrastructure design and implementation planning to support your strategy. The high-level architectures provided by the assessment service are turned into low level designs and wiring diagrams, which are reviewed and approved prior to implementation. The implementation plan will demonstrate an outcome-based proposal to provide business capabilities through infrastructure with a risk-mitigated project plan.

- **Basic Hardware Installation**

Lenovo experts can seamlessly manage the physical installation of your server, storage, or networking hardware. Working at a time convenient for you (business hours or off shift), the technician will unpack and inspect the systems on your site, install options, mount in a rack cabinet, connect to power and network, check and update firmware to the latest levels, verify operation, and dispose of the packaging, allowing your team to focus on other priorities.

- **Deployment Services**

When investing in new IT infrastructures, you need to ensure your business will see quick time to value with little to no disruption. Lenovo deployments are designed by development and engineering teams who know our Products & Solutions better than anyone else, and our technicians own the process from delivery to completion. Lenovo will conduct remote preparation and planning, configure & integrate systems, validate systems, verify and update appliance firmware, train on administrative tasks, and provide post-deployment documentation. Customer's IT teams leverage our skills to enable IT staff to transform with higher level roles and tasks.

- **Integration, Migration, and Expansion Services**

Move existing physical & virtual workloads easily, or determine technical requirements to support increased workloads while maximizing performance. Includes tuning, validation, and documenting ongoing run processes. Leverage migration assessment planning documents to perform necessary migrations.



## Regulatory compliance

The SR850 V3 conforms to the following standards:

- ANSI/UL 62368-1
- IEC 62368-1 (CB Certificate and CB Test Report)
- CSA C22.2 No. 62368-1
- Argentina IEC 60950-1
- Mexico NOM-019
- India BIS 13252 (Part 1)
- Germany GS
- TUV-GS (EN62368-1, and EK1-ITB2000)
- Brazil INMETRO
- South Africa NRCS LOA
- Ukraine UkrCEPRO
- Morocco CMIM Certification (CM)
- Russia, Belorussia and Kazakhstan, TP EAC 037/2016 (for RoHS)
- Russia, Belorussia and Kazakhstan, EAC: TP TC 004/2011 (for Safety); TP TC 020/2011 (for EMC)
- CE, UKCA Mark (EN55032 Class A, EN62368-1, EN55024, EN55035, EN61000-3-2, EN61000-3-3, (EU) 2019/424, and EN IEC 63000 (RoHS))
- FCC - Verified to comply with Part 15 of the FCC Rules, Class A
- Canada ICES-003, issue 7, Class A
- CISPR 32, Class A, CISPR 35
- Korea KN32, Class A, KN35
- Japan VCCI, Class A
- Taiwan BSMI CNS15936, Class A; CNS15598-1; Section 5 of CNS15663
- Australia/New Zealand AS/NZS CISPR 32, Class A; AS/NZS 62368.1
- UL Green Guard, UL2819
- [Energy Star 4.0](#)
- EPEAT (NSF/ ANSI 426) Bronze
- Japanese Energy-Saving Act
- EU2019/424 Energy Related Product (ErP Lot9)
- China CELP certificate, HJ 2507-2011

## External drive enclosures

The server supports attachment to external drive enclosures using a RAID controller with external ports or a SAS host bus adapter. Adapters supported by the server are listed in the [SAS adapters for external storage](#) section.

**Note:** Information provided in this section is for ordering reference purposes only. For the operating system and adapter support details, refer to the interoperability matrix for a particular storage enclosure that can be found on the Lenovo Data Center Support web site:

<http://datacentersupport.lenovo.com>

Table 57. External drive enclosures

Model	Description
4587HC1	Lenovo Storage D1212 Disk Expansion Enclosure (2U enclosure with 12x LFF drive bays)
4587HC2	Lenovo Storage D1224 Disk Expansion Enclosure (2U enclosure with 24x SFF drive bays)
6413HC1	Lenovo Storage D3284 High Density Expansion Enclosure (5U enclosure with 84x LFF drive bays)
7DAHCTO1WW	Lenovo ThinkSystem D4390 Direct Attached Storage (4U enclosure with 90x LFF drive bays)

For details about supported drives, adapters, and cables, see the following Lenovo Press Product Guides:

- Lenovo Storage D1212 and D1224  
<http://lenovopress.lenovo.com/lp0512>
- Lenovo Storage D3284  
<http://lenovopress.lenovo.com/lp0513>
- Lenovo ThinkSystem D4390  
<https://lenovopress.lenovo.com/lp1681>

## External storage systems

Lenovo offers the ThinkSystem DE Series and ThinkSystem DM Series external storage systems for high-performance storage. See the DE Series and DM Series product guides for specific controller models, expansion enclosures and configuration options:

- ThinkSystem DE Series Storage  
<https://lenovopress.com/storage/thinksystem/de-series#rt=product-guide>
- ThinkSystem DM Series Storage  
<https://lenovopress.com/storage/thinksystem/dm-series#rt=product-guide>
- ThinkSystem DG Series Storage  
<https://lenovopress.com/storage/thinksystem/dg-series#rt=product-guide>

## External backup units

The following table lists the external backup options that are offered by Lenovo.

Table 58. External backup options

Part number	Description
External RDX USB drives	
4T27A10725	ThinkSystem RDX External USB 3.0 Dock
External SAS tape backup drives	
6160S7E	IBM TS2270 Tape Drive Model H7S

Part number	Description
6160S8E	IBM TS2280 Tape Drive Model H8S
6160S9E	IBM TS2290 Tape Drive Model H9S
External SAS tape backup autoloaders	
6171S7R	IBM TS2900 Tape Autoloader w/LTO7 HH SAS
6171S8R	IBM TS2900 Tape Autoloader w/LTO8 HH SAS
6171S9R	IBM TS2900 Tape Autoloader w/LTO9 HH SAS
External tape backup libraries	
6741A1F	IBM TS4300 3U Tape Library-Base Unit
6741A3F	IBM TS4300 3U Tape Library-Expansion Unit
Full High 8 Gb Fibre Channel for TS4300	
01KP938	LTO 7 FH Fibre Channel Drive
01KP954	LTO 8 FH Fibre Channel Drive
02JH837	LTO 9 FH Fibre Channel Drive
Half High 8 Gb Fibre Channel for TS4300	
01KP936	LTO 7 HH Fibre Channel Drive
01KP952	LTO 8 HH Fibre Channel Drive
02JH835	LTO 9 HH Fibre Channel Drive
Half High 6 Gb SAS for TS4300	
01KP937	LTO 7 HH SAS Drive
01KP953	LTO 8 HH SAS Drive
02JH836	LTO 9 HH SAS Drive

For more information, see the list of Product Guides in the Backup units category:  
<https://lenovopress.com/servers/options/backup>

## Fibre Channel SAN switches

Lenovo offers the ThinkSystem DB Series of Fibre Channel SAN switches for high-performance storage expansion. See the DB Series product guides for models and configuration options:

- ThinkSystem DB Series SAN Switches:  
<https://lenovopress.com/storage/switches/rack#rt=product-guide>

## Uninterruptible power supply units

The following table lists the uninterruptible power supply (UPS) units that are offered by Lenovo.

Table 59. Uninterruptible power supply units

Part number	Description
55941AX	RT1.5kVA 2U Rack or Tower UPS (100-125VAC)
55941KX	RT1.5kVA 2U Rack or Tower UPS (200-240VAC)
55942AX	RT2.2kVA 2U Rack or Tower UPS (100-125VAC)
55942KX	RT2.2kVA 2U Rack or Tower UPS (200-240VAC)
55943AX	RT3kVA 2U Rack or Tower UPS (100-125VAC)
55943KX	RT3kVA 2U Rack or Tower UPS (200-240VAC)
55945KX	RT5kVA 3U Rack or Tower UPS (200-240VAC)
55946KX	RT6kVA 3U Rack or Tower UPS (200-240VAC)
55948KX	RT8kVA 6U Rack or Tower UPS (200-240VAC)
55949KX	RT11kVA 6U Rack or Tower UPS (200-240VAC)
55948PX	RT8kVA 6U 3:1 Phase Rack or Tower UPS (380-415VAC)
55949PX	RT11kVA 6U 3:1 Phase Rack or Tower UPS (380-415VAC)
55943KT†	ThinkSystem RT3kVA 2U Standard UPS (200-230VAC) (2x C13 10A, 2x GB 10A, 1x C19 16A outlets)
55943LT†	ThinkSystem RT3kVA 2U Long Backup UPS (200-230VAC) (2x C13 10A, 2x GB 10A, 1x C19 16A outlets)
55946KT†	ThinkSystem RT6kVA 5U UPS (200-230VAC) (2x C13 10A outlets, 1x Terminal Block output)
5594XKT†	ThinkSystem RT10kVA 5U UPS (200-230VAC) (2x C13 10A outlets, 1x Terminal Block output)

† Only available in China and the Asia Pacific market.

For more information, see the list of Product Guides in the UPS category:

<https://lenovopress.com/servers/options/ups>

## Power distribution units

The following table lists the power distribution units (PDUs) that are offered by Lenovo.

Table 60. Power distribution units

Part number	Feature code	Description	ANZ	ASEAN	Brazil	EET	MEA	RUCIS	WE	HTK	INDIA	JAPAN	LA	NA	PRC
<b>0U Basic PDUs</b>															
00YJ776	ATZY	0U 36 C13/6 C19 24A 1 Phase PDU	N	Y	Y	N	N	N	N	N	N	Y	Y	Y	N
<b>0U Switched and Monitored PDUs</b>															
00YJ783	AU04	0U 12 C13/12 C19 Switched and Monitored 48A 3 Phase PDU	N	N	Y	N	N	N	Y	N	N	Y	Y	Y	N
00YJ781	AU03	0U 20 C13/4 C19 Switched and Monitored 24A 1 Phase PDU	N	N	Y	N	Y	N	Y	N	N	Y	Y	Y	N
<b>1U Switched and Monitored PDUs</b>															

Part number	Feature code	Description	ANZ	ASEAN	Brazil	EET	MEA	RUCIS	WE	HTK	INDIA	JAPAN	LA	NA	PRC
4PU7A81117	BNDV	1U 18 C19/C13 switched and monitored 48A 3P WYE PDU - ETL	N	N	N	N	N	N	N	N	N	N	N	Y	N
4PU7A77467	BLC4	1U 18 C19/C13 Switched and Monitored 80A 3P Delta PDU	N	N	N	N	N	N	N	N	N	Y	N	Y	N
4PU7A77469	BLC6	1U 12 C19/C13 switched and monitored 60A 3P Delta PDU	N	N	N	N	N	N	N	N	N	N	N	Y	N
4PU7A77468	BLC5	1U 12 C19/C13 switched and monitored 32A 3P WYE PDU	Y	Y	Y	Y	Y	Y	Y	Y	Y	N	Y	Y	Y
4PU7A81118	BNDW	1U 18 C19/C13 switched and monitored 48A 3P WYE PDU - CE	Y	Y	Y	Y	Y	Y	Y	Y	Y	N	Y	N	Y
<b>1U Ultra Density Enterprise PDUs (9x IEC 320 C13 + 3x IEC 320 C19 outlets)</b>															
71763NU	6051	Ultra Density Enterprise C19/C13 PDU 60A/208V/3PH	N	N	Y	N	N	N	N	N	N	Y	Y	Y	N
71762NX	6091	Ultra Density Enterprise C19/C13 PDU Module	Y	Y	Y	Y	Y	Y	Y	Y	Y	Y	Y	Y	Y
<b>1U C13 Enterprise PDUs (12x IEC 320 C13 outlets)</b>															
39Y8941	6010	DPI C13 Enterprise PDU Module (WW)	Y	Y	Y	Y	Y	Y	Y	Y	Y	Y	Y	Y	Y
<b>1U Front-end PDUs (3x IEC 320 C19 outlets)</b>															
39Y8938	6002	DPI Single-phase 30A/120V Front-end PDU (US)	Y	Y	Y	Y	Y	Y	Y	Y	Y	Y	Y	Y	Y
39Y8939	6003	DPI Single-phase 30A/208V Front-end PDU (US)	Y	Y	Y	Y	Y	Y	Y	Y	Y	Y	Y	Y	Y
39Y8934	6005	DPI Single-phase 32A/230V Front-end PDU (International)	Y	Y	Y	Y	Y	Y	Y	Y	Y	Y	Y	Y	Y
39Y8940	6004	DPI Single-phase 60A/208V Front-end PDU (US)	Y	N	Y	Y	Y	Y	Y	N	N	Y	Y	Y	N
39Y8935	6006	DPI Single-phase 63A/230V Front-end PDU (International)	Y	Y	Y	Y	Y	Y	Y	Y	Y	Y	Y	Y	Y
<b>1U NEMA PDUs (6x NEMA 5-15R outlets)</b>															
39Y8905	5900	DPI 100-127V NEMA PDU	Y	Y	Y	Y	Y	Y	Y	Y	Y	Y	Y	Y	Y
<b>Line cords for 1U PDUs that ship without a line cord</b>															
40K9611	6504	4.3m, 32A/380-415V, EPDU/IEC 309 3P+N+G 3ph wye (non-US) Line Cord	Y	Y	Y	Y	Y	Y	Y	Y	Y	Y	Y	Y	Y
40K9612	6502	4.3m, 32A/230V, EPDU to IEC 309 P+N+G (non-US) Line Cord	Y	Y	Y	Y	Y	Y	Y	Y	Y	Y	Y	Y	Y
40K9613	6503	4.3m, 63A/230V, EPDU to IEC 309 P+N+G (non-US) Line Cord	Y	Y	Y	Y	Y	Y	Y	Y	Y	Y	Y	Y	Y
40K9614	6500	4.3m, 30A/208V, EPDU to NEMA L6-30P (US) Line Cord	Y	Y	Y	Y	Y	Y	Y	Y	Y	Y	Y	Y	Y
40K9615	6501	4.3m, 60A/208V, EPDU to IEC 309 2P+G (US) Line Cord	N	N	Y	N	N	N	Y	N	N	Y	Y	Y	N
40K9617	6505	4.3m, 32A/230V, Souriau UTG Female to AS/NZ 3112 (Aus/NZ) Line Cord	Y	Y	Y	Y	Y	Y	Y	Y	Y	Y	Y	Y	Y

Part number	Feature code	Description	ANZ	ASEAN	Brazil	EET	MEA	RUCIS	WE	HTK	INDIA	JAPAN	LA	NA	PRC
40K9618	6506	4.3m, 32A/250V, Souriau UTG Female to KSC 8305 (S. Korea) Line Cord	Y	Y	Y	Y	Y	Y	Y	Y	Y	Y	Y	Y	Y

For more information, see the Lenovo Press documents in the PDU category:  
<https://lenovopress.com/servers/options/pdu>

## Rack cabinets

The following table lists the supported rack cabinets.

Table 61. Rack cabinets

Part number	Description
93072RX	25U Standard Rack (1000mm)
93072PX	25U Static S2 Standard Rack (1000mm)
7D6DA007WW	ThinkSystem 42U Onyx Primary Heavy Duty Rack Cabinet (1200mm)
7D6DA008WW	ThinkSystem 42U Pearl Primary Heavy Duty Rack Cabinet (1200mm)
1410-O42	Lenovo EveryScale 42U Onyx Heavy Duty Rack Cabinet
1410-P42	Lenovo EveryScale 42U Pearl Heavy Duty Rack Cabinet
93604PX	42U 1200mm Deep Dynamic Rack
93614PX	42U 1200mm Deep Static Rack
93634PX	42U 1100mm Dynamic Rack
93634EX	42U 1100mm Dynamic Expansion Rack
93074RX	42U Standard Rack (1000mm)
7D6EA009WW	ThinkSystem 48U Onyx Primary Heavy Duty Rack Cabinet (1200mm)
7D6EA00AWW	ThinkSystem 48U Pearl Primary Heavy Duty Rack Cabinet (1200mm)
1410-O48	Lenovo EveryScale 48U Onyx Heavy Duty Rack Cabinet
1410-P48	Lenovo EveryScale 48U Pearl Heavy Duty Rack Cabinet

For specifications about these racks, see the Lenovo Rack Cabinet Reference, available from:  
<https://lenovopress.com/lp1287-lenovo-rack-cabinet-reference>

For more information, see the list of Product Guides in the Rack cabinets category:  
<https://lenovopress.com/servers/options/racks>

**Installation restriction - 1100mm racks and the use of the CMA :** The SR850 V3 with the cable management arm (CMA) attached is supported in 1100mm rack cabinets, however there is insufficient clearance to route any cables between the CMA and the rear door. As a result, if you require cable access through the lower cable access panel of the rack and you have an SR850 V3 installed at the bottom position of the rack, then it is not supported to use a CMA with that server. Similarly, if you require cable access through the upper cable access panel of the rack and you have an SR850 V3 installed at the top position of the rack, then it is not supported to use a CMA with that server. This limitation does not exist with rack cabinets with 1200mm depth.

## KVM console options

The following table lists the supported KVM consoles.

Table 62. KVM console

Part number	Description
4XF7A84188	ThinkSystem 18.5" LCD Console (with US English keyboard)

The following table lists the available KVM switches and the options that are supported with them.

Table 64. KVM switches and options

Part number	Description
KVM Console switches	
1754D2X	Global 4x2x32 Console Manager (GCM32)
1754D1X	Global 2x2x16 Console Manager (GCM16)
1754A2X	Local 2x16 Console Manager (LCM16)
1754A1X	Local 1x8 Console Manager (LCM8)
Cables for GCM and LCM Console switches	
46M5383	Virtual Media Conversion Option Gen2 (VCO2)
46M5382	Serial Conversion Option (SCO)

For more information, see the list of Product Guides in the KVM Switches and Consoles category:

<http://lenovopress.com/servers/options/kvm>

## Lenovo Financial Services

Lenovo Financial Services reinforces Lenovo's commitment to deliver pioneering products and services that are recognized for their quality, excellence, and trustworthiness. Lenovo Financial Services offers financing solutions and services that complement your technology solution anywhere in the world.

We are dedicated to delivering a positive finance experience for customers like you who want to maximize your purchase power by obtaining the technology you need today, protect against technology obsolescence, and preserve your capital for other uses.

We work with businesses, non-profit organizations, governments and educational institutions to finance their entire technology solution. We focus on making it easy to do business with us. Our highly experienced team of finance professionals operates in a work culture that emphasizes the importance of providing outstanding customer service. Our systems, processes and flexible policies support our goal of providing customers with a positive experience.

We finance your entire solution. Unlike others, we allow you to bundle everything you need from hardware and software to service contracts, installation costs, training fees, and sales tax. If you decide weeks or months later to add to your solution, we can consolidate everything into a single invoice.

Our Premier Client services provide large accounts with special handling services to ensure these complex transactions are serviced properly. As a premier client, you have a dedicated finance specialist who manages your account through its life, from first invoice through asset return or purchase. This specialist develops an in-depth understanding of your invoice and payment requirements. For you, this dedication provides a high-quality, easy, and positive financing experience.

For your region-specific offers, please ask your Lenovo sales representative or your technology provider about the use of Lenovo Financial Services. For more information, see the following Lenovo website:

<https://www.lenovo.com/us/en/landingpage/lenovo-financial-services/>

## Seller training courses

The following sales training courses are offered for employees and partners (login required). Courses are listed in date order.

- 1. Partner Technical Webinar - ISG Portfolio Update**  
2024-04-15 | 60 minutes | Employees and Partners

In this 60-minute replay, Mark Bica, NA ISG Server Product Manager reviewed the Lenovo ISG portfolio. He covered new editions such as the SR680a \ SR685a, dense servers, and options that are strategic for any workload.

Published: 2024-04-15

Length: 60 minutes

Employee link: [Grow@Lenovo](#)

Partner link: [Lenovo Partner Learning](#)

Course code: 041224



2. **Partner Technical Webinar – StorMagic**  
2024-03-19 | 60 minutes | Employees and Partners

March 08, 2024 – In this 60-minute replay, Stuart Campbell and Wes Ganeko of StorMagic joined us and provided an overview of StorMagic on Lenovo. They also demonstrated the interface while sharing some interesting use cases.

Published: 2024-03-19  
Length: 60 minutes  
Employee link: [Grow@Lenovo](#)  
Partner link: [Lenovo Partner Learning](#)  
Course code: 030824

3. **Intel Transparent Supply Chain on Lenovo Servers**  
2024-01-29 | 12 minutes | Employees and Partners

This course introduces the Intel Transparent Supply Chain (TSC) program, explains how the program works, and discusses the benefits of the Intel TSC program to customers. Adding the Intel TSC feature to an order is explained.

Course objectives:

- Describe the Intel® Transparent Supply Chain program
- Explain how the Intel® Transparent Supply Chain program works
- Discuss the benefits of the Intel® Transparent Supply Chain program to Lenovo customers
- Explain how to add Intel® Transparent Supply Chain program feature to an order

Published: 2024-01-29  
Length: 12 minutes  
Employee link: [Grow@Lenovo](#)  
Partner link: [Lenovo Partner Learning](#)  
Course code: SXXW1230

4. **Family Portfolio: Storage Controller Options**  
2024-01-23 | 25 minutes | Employees and Partners

This course covers the storage controller options available for use in Lenovo servers. The classes of storage controller are discussed, along with a discussion of where they are used, and which to choose.

After completing this course, you will be able to:

- Describe the classes of storage controllers
- Discuss where each controller class is used
- Describe the available options in each controller class

Published: 2024-01-23  
Length: 25 minutes  
Employee link: [Grow@Lenovo](#)  
Partner link: [Lenovo Partner Learning](#)  
Course code: SXXW1111

**5. Lenovo-Intel Sustainable Solutions QH**  
2024-01-22 | 10 minutes | Employees and Partners

This Quick Hit explains how Lenovo and Intel are committed to sustainability, and introduces the Lenovo-Intel joint sustainability campaign. You will learn how to use this campaign to show customers what that level of commitment entails, how to use the campaign's unsolicited proposal approach, and how to use the campaign as a conversation starter which may lead to increased sales.

Published: 2024-01-22  
Length: 10 minutes  
Employee link: [Grow@Lenovo](#)  
Partner link: [Lenovo Partner Learning](#)  
Course code: SXXW2524a

**6. FY24Q3 Intel Servers Update**  
2023-12-11 | 15 minutes | Employees and Partners

This update is designed to help you discuss the features and customer benefits of Lenovo servers that use the 5th Gen Intel® Xeon® processors. Lenovo has also introduced a new server, the ThinkSystem SD650-N V3, which expands the supercomputer server family. Reasons to call your customer and talk about refreshing their infrastructure are also included as a guideline.

Published: 2023-12-11  
Length: 15 minutes  
Employee link: [Grow@Lenovo](#)  
Partner link: [Lenovo Partner Learning](#)  
Course code: SXXW2522a

**7. Lenovo Data Center Product Portfolio**  
2023-07-21 | 15 minutes | Employees and Partners

This course introduces the Lenovo data center portfolio, and covers servers, storage, storage networking, and software-defined infrastructure products. After completing this course about Lenovo data center products, you will be able to identify product types within each data center family, describe Lenovo innovations that this product family or category uses, and recognize when a specific product should be selected.

Published: 2023-07-21  
Length: 15 minutes  
Employee link: [Grow@Lenovo](#)  
Partner link: [Lenovo Partner Learning](#)  
Course code: SXXW1110r6

**8. VTT: SAP HANA Transition and Refresh Opportunity - July 2023**  
2023-07-14 | 60 minutes | Employees Only

In this session, we cover:

- What Next for SAP Clients?
- Lenovo Opportunity
- Lenovo Portfolio for SAP Solutions
- RISE with SAP

Published: 2023-07-14  
Length: 60 minutes  
Employee link: [Grow@Lenovo](#)  
Course code: DV DAT202

9. **Partner Technical Webinar - Data Center Limits and ISG TAA Compliance**

2023-05-16 | 60 minutes | Employees and Partners

In this 60-minute replay, we had two topics. First Vinod Kamath, Lenovo Distinguished Engineer for Data Center Cooling presented on the Systems Configuration and Data Center Ambient Limits. Second, Shama Patari, Lenovo Trade Council, and Glenn Johnson, Lenovo Principal Engineer for Supply Chain presented on ISG TAA Compliance.

Published: 2023-05-16

Length: 60 minutes

Employee link: [Grow@Lenovo](mailto:Grow@Lenovo)

Partner link: [Lenovo Partner Learning](#)

Course code: 051223

10. **Family Portfolio: ThinkSystem Intel Mission Critical Servers**

2023-01-09 | 10 minutes | Employees and Partners

This course is designed to give Lenovo sales and partner representatives the foundation of the Intel Mission Critical server family of products. As an introduction to the products, this course also includes Lenovo innovations and when to select a specific product.

When you finish this course, you should be able to identify products and features within the family, describe Lenovo innovations that this product family uses, and recognize when a specific product or products should be selected.

Published: 2023-01-09

Length: 10 minutes

Employee link: [Grow@Lenovo](mailto:Grow@Lenovo)

Partner link: [Lenovo Partner Learning](#)

Course code: SXXW1209r6

11. **Family Portfolio Intel Mission Critical Servers V3 Preview**

2023-01-04 | 3 minutes | Employees and Partners

This Quick Hit introduces two new servers, the SR850 V3 and SR860 V3, in the ThinkSystem Intel Mission Critical server family, and introduces new features.

Note: This course is presented as audio only. There are no slides or video.

Published: 2023-01-04

Length: 3 minutes

Employee link: [Grow@Lenovo](mailto:Grow@Lenovo)

Partner link: [Lenovo Partner Learning](#)

Course code: SXXW1209r6a

12. **Introduction to the Intel Xeon Scalable Gen4 Processors**

2022-12-30 | 10 minutes | Employees and Partners

When you complete this course, you should be able to define the Gen4 Intel Xeon Scalable processors and the four tiers used in the family. You should also be able to discuss the new features of the Gen4 processors and the family value proposition.

Published: 2022-12-30

Length: 10 minutes

Employee link: [Grow@Lenovo](mailto:Grow@Lenovo)

Partner link: [Lenovo Partner Learning](#)

Course code: SXXW2500

13. **Technical Champions Webinar: ThinkSystem V3 Servers using Intel Eagle Stream**  
2022-12-08 | 86 minutes | Employees Only

This webinar discusses the key new features of the Intel Eagle Stream platform and its implementation in the ThinkSystem Server portfolio. This webinar will cover what has changed from the previous generation of servers, and timeframes for availability.

Published: 2022-12-08  
Length: 86 minutes  
Employee link: [Grow@Lenovo](#)  
Course code: DTSP201

14. **Lenovo Infrastructure Solutions Launch**  
2022-09-16 | 8 minutes | Employees and Partners

This Quick Hit introduces a wealth of new products, solutions, and services announced as part of the Lenovo ThinkSystem 30th Anniversary celebration.

Published: 2022-09-16  
Length: 8 minutes  
Employee link: [Grow@Lenovo](#)  
Partner link: [Lenovo Partner Learning](#)  
Course code: FY23Q2a

15. **Lenovo Sustainable Computing**  
2022-09-16 | 4 minutes | Employees and Partners

This Quick Hit describes the Lenovo sustainable computing program, and the many ways in which Lenovo strives to respect and protect the environment.

Published: 2022-09-16  
Length: 4 minutes  
Employee link: [Grow@Lenovo](#)  
Partner link: [Lenovo Partner Learning](#)  
Course code: SXXW2504a

16. **Introduction to DDR5 Memory**  
2022-08-23 | 10 minutes | Employees and Partners

This course introduces DDR5 memory, describes new features of this memory generation, and discusses the advantages to customers of this new memory generation.

Published: 2022-08-23  
Length: 10 minutes  
Employee link: [Grow@Lenovo](#)  
Partner link: [Lenovo Partner Learning](#)  
Course code: SXXW2502

## Related publications and links

For more information, see these resources:

- Product web page for the ThinkSystem SR850 V3:  
<https://www.lenovo.com/us/en/p/mission-critical/len21ts0015>
- Datasheet for the SR850 V3  
<https://lenovopress.lenovo.com/DS0155>
- Interactive 3D Tour of the ThinkSystem SR850 V3:  
<https://lenovopress.lenovo.com/lp1625>
- ThinkSystem SR850 V3 drivers and support  
<http://datacentersupport.lenovo.com/products/servers/thinksystem/sr850-v3/7d96/downloads>
- Lenovo ThinkSystem SR850 V3 product publications:  
<http://thinksystem.lenovofiles.com/help/index.jsp>
  - Quick Start
  - Rack Installation Guide
  - Setup Guide
  - Hardware Maintenance Manual
  - Messages and Codes Reference
  - Memory Population Reference
- ServerProven hardware compatibility:  
<https://serverproven.lenovo.com/>

## Related product families

Product families related to this document are the following:

- [4-Socket Rack Servers](#)
- [Mission Critical Servers](#)
- [ThinkSystem SR850 V3 Server](#)

## Notices

Lenovo may not offer the products, services, or features discussed in this document in all countries. Consult your local Lenovo representative for information on the products and services currently available in your area. Any reference to a Lenovo product, program, or service is not intended to state or imply that only that Lenovo product, program, or service may be used. Any functionally equivalent product, program, or service that does not infringe any Lenovo intellectual property right may be used instead. However, it is the user's responsibility to evaluate and verify the operation of any other product, program, or service. Lenovo may have patents or pending patent applications covering subject matter described in this document. The furnishing of this document does not give you any license to these patents. You can send license inquiries, in writing, to:

Lenovo (United States), Inc.  
8001 Development Drive  
Morrisville, NC 27560  
U.S.A.  
Attention: Lenovo Director of Licensing

LENOVO PROVIDES THIS PUBLICATION "AS IS" WITHOUT WARRANTY OF ANY KIND, EITHER EXPRESS OR IMPLIED, INCLUDING, BUT NOT LIMITED TO, THE IMPLIED WARRANTIES OF NON-INFRINGEMENT, MERCHANTABILITY OR FITNESS FOR A PARTICULAR PURPOSE. Some jurisdictions do not allow disclaimer of express or implied warranties in certain transactions, therefore, this statement may not apply to you.

This information could include technical inaccuracies or typographical errors. Changes are periodically made to the information herein; these changes will be incorporated in new editions of the publication. Lenovo may make improvements and/or changes in the product(s) and/or the program(s) described in this publication at any time without notice.

The products described in this document are not intended for use in implantation or other life support applications where malfunction may result in injury or death to persons. The information contained in this document does not affect or change Lenovo product specifications or warranties. Nothing in this document shall operate as an express or implied license or indemnity under the intellectual property rights of Lenovo or third parties. All information contained in this document was obtained in specific environments and is presented as an illustration. The result obtained in other operating environments may vary. Lenovo may use or distribute any of the information you supply in any way it believes appropriate without incurring any obligation to you.

Any references in this publication to non-Lenovo Web sites are provided for convenience only and do not in any manner serve as an endorsement of those Web sites. The materials at those Web sites are not part of the materials for this Lenovo product, and use of those Web sites is at your own risk. Any performance data contained herein was determined in a controlled environment. Therefore, the result obtained in other operating environments may vary significantly. Some measurements may have been made on development-level systems and there is no guarantee that these measurements will be the same on generally available systems. Furthermore, some measurements may have been estimated through extrapolation. Actual results may vary. Users of this document should verify the applicable data for their specific environment.

© Copyright Lenovo 2024. All rights reserved.

This document, LP1605, was created or updated on January 26, 2024.

Send us your comments in one of the following ways:

- Use the online Contact us review form found at:  
<https://lenovopress.lenovo.com/LP1605>
- Send your comments in an e-mail to:  
[comments@lenovopress.com](mailto:comments@lenovopress.com)

This document is available online at <https://lenovopress.lenovo.com/LP1605>.

## Trademarks

Lenovo and the Lenovo logo are trademarks or registered trademarks of Lenovo in the United States, other countries, or both. A current list of Lenovo trademarks is available on the Web at <https://www.lenovo.com/us/en/legal/copytrade/>.

The following terms are trademarks of Lenovo in the United States, other countries, or both:

Lenovo®  
AnyBay®  
Bootable Media Creator  
Flex System  
Lenovo Services  
ServerProven®  
System x®  
ThinkAgile®  
ThinkShield®  
ThinkServer®  
ThinkSystem®  
UpdateXpress System Packs  
XClarity®

The following terms are trademarks of other companies:

Intel®, Intel Optane™, and Xeon® are trademarks of Intel Corporation or its subsidiaries.

Linux® is the trademark of Linus Torvalds in the U.S. and other countries.

Microsoft®, ActiveX®, Hyper-V®, PowerShell, Windows PowerShell®, Windows Server®, and Windows® are trademarks of Microsoft Corporation in the United States, other countries, or both.

SPECpower® is a trademark of the Standard Performance Evaluation Corporation (SPEC).

Other company, product, or service names may be trademarks or service marks of others.