

System x3750 M4 (8752) Product Guide (withdrawn product)

The System x3750 M4 is a 4-socket server featuring a streamlined design, optimized for price and performance, with best-in-class flexibility and expandability. Models of the x3750 M4, machine type 8752, are powered with Intel Xeon E5-4600 v2 processors, up to 12 cores each, for an entry-level 4-socket solution. The x3750 M4 provides maximum storage density, with flexible PCI and 10 Gb Ethernet networking options in a 2U form factor.

Suggested uses: High performance computing (HPC), workloads with floating-point computations, and small to medium databases requiring fast I/O; applications that require 4-socket performance without needing the scalability that the X6 systems provide.



Figure 1. The System x3750 M4

Did you know?

With a dense 2U design, the System x3750 M4 provides advanced features and capabilities. These include support for up to four sockets and 48 DIMMs, mix and match internal storage, up to 16 HDDs or 32 eXFlash solid-state drives (SSDs), six hot-swap, dual-rotor fans and two power supplies.

A Mezzanine LOM socket provides a choice of 1 Gigabit Ethernet (GbE) or 10 GbE networking options. Predictive Failure Analysis and light path diagnostics proactively monitor the system's sub-components and provide advanced warning on power supplies, fans, drives, processors and memory.

Key features

The System x3750 M4 blends outstanding flexibility and expandability. The x3750 M4 2+2 socket design enables pay-as-you-grow processing with the new Intel Xeon E5-4600 v2 series processors and memory scalability to help lower cost and manage growth. The 5+3 PCIe socket design allows you to pay for PCIe capabilities as needed.

With the capability to support up to 48 DIMMs, four sockets, mix and match internal storage with up to 16 HDDs or 32 eXFlash SSD drives, 6 hot-swap dual rotor fans, two power supplies, and a dedicated slot for Gigabit or 10 GbE networking with options, the x3750 M4 provides unmatched features and capabilities in a dense 2U design.

Scalability and performance

The x3750 M4 offers numerous features to boost performance, improve scalability, and reduce costs:

- The Intel Xeon processor E5-4600 v2 family improves productivity by offering superior system performance. It provides increased productivity by offering processors up to 12 cores each and processors with core speeds up to 3.3 GHz, L3 cache up to 30 MB, and two QuickPath Interconnect (QPI) interconnect links operating at up to 8 GTps.
- The x3750 M4 2+2 processor socket design enables pay-as-you-grow processing with the Intel Xeon E5-4600 v2 series processors and memory scalability to help lower cost and manage growth.
- Up to four processors, 48 cores, and 96 threads maximize the concurrent execution of multithreaded applications.
- Intelligent and adaptive system performance with Intel Turbo Boost Technology 2.0 allows processor cores to run at maximum speeds during peak workloads by temporarily going beyond processor TDP.
- Intel Hyper-Threading Technology boosts performance for multithreaded applications by enabling simultaneous multithreading within each processor core, up to two threads per core.
- Intel Virtualization Technology integrates hardware-level virtualization hooks that allow operating system vendors to better use the hardware for virtualization workloads.
- 48 Load Reduced DIMMs (LRDIMMs) of 1866 MHz DDR3 ECC memory provide speed, high availability, and a memory capacity of up to 1.5 TB.
- The use of eXFlash solid-state drives (SSDs) instead of, or along with, traditional spinning drives (HDDs), can improve I/O performance. An SSD can support up to 100 times more I/O operations per second (IOPS) than a typical HDD.
- Up to 16 HDDs or 32 eXFlash SSDs, together with an optical drive at the same time, provide a flexible and scalable all-in-one platform to meet your increasing demands.
- The server offers a SAS switch backplane option to allow up to 16x 2.5-inch drives to attach to a single controller.
- The 5+3 PCI Express socket design of the server allows you to pay for PCIe capabilities as needed.
- The server has a dedicated flexible mezzanine LOM slot offering a variety of 10 GbE or Gigabit Ethernet adapters that do not occupy one of the 8 standard PCIe slots .
- The server offers PCI Express 3.0 I/O expansion capabilities that improve the theoretical maximum bandwidth by almost 100% (8 GTps per link using 128b/130b encoding) compared to the previous generation of PCI Express 2.0 (5 GTps per link using 8b/10b encoding).
- With Intel Integrated I/O Technology, the PCI Express 3.0 controller is integrated into the Intel Xeon processor E5 family. This integration reduces I/O latency and increases overall system performance.

Availability and serviceability

The x3750 M4 provides many features to simplify serviceability and increase system uptime:

- The server offers Chipkill, memory mirroring, and memory rank sparing for redundancy in the event of a memory failure.
- The server provides restart recovery for any failed processor. If a failure of processor 1 occurs, the server connects the Southbridge to processor 2 for reboot.
- Tool-less cover removal provides easy access to upgrades and serviceable parts, such as the processor,

memory, and adapter cards.

- The server offers hot-swap drives, supporting RAID redundancy for data protection and greater system uptime.
- The server has up to two redundant hot-swap power supplies and six hot-swap dual-rotor N+N redundant fans to provide availability for business-critical applications.
- The power source independent light path diagnostics panel and individual light path LEDs lead the technician to failed (or failing) components, which simplifies servicing, speeds up problem resolution, and helps improve system availability.
- The x3750 M4 provides error checking, Predictive Failure Analysis (PFA), or both on the following components. Alerts are generated in advance of a possible failure, therefore increasing uptime.
 - Memory ECC correction (Chipkill technology)
 - Microprocessor built-in self test (BIST) and internal error checking
 - PCIe Bus parity checking
 - SAS Bus Parity
 - HDD and SSD drive CRC checking
 - Diskette CRC checking
 - USB CRC checking
 - Over temperature detection
 - Over/under voltage detection
 - Power supply error checking
 - Fan failure detection
 - Serial interface parity, overrun, and frame checking
- Solid-state drives (SSDs) offer more reliability than traditional mechanical HDDs for greater uptime.
- The built-in Integrated Management Module Version II (IMM2) continuously monitors system parameters, triggers alerts, and performs recovery actions in case of failures to minimize downtime.
- Built-in diagnostics, using Dynamic Systems Analysis (DSA) Preboot, speed up troubleshooting tasks to reduce service time.
- Three-year customer-replaceable unit and onsite limited warranty, 9 x 5 next business day. Optional service upgrades are available.

Manageability and security

Powerful systems management features simplify local and remote management of the x3750 M4:

- The server includes an Integrated Management Module II (IMM2) to monitor server availability and perform remote management. Remote presence support is standard.
- The integrated industry-standard Unified Extensible Firmware Interface (UEFI) enables improved setup, configuration, and updates, and simplifies error handling.
- Integrated Trusted Platform Module (TPM) 1.2 support enables advanced cryptographic functionality, such as digital signatures and remote attestation.
- Industry-standard Advanced Encryption Standard (AES) NI support for faster, stronger encryption.
- IBM Systems Director is included for proactive systems management. It offers comprehensive systems management tools that increases uptime, reduces costs, and improves productivity through advanced server management capabilities.
- Intel Execute Disable Bit functionality can prevent certain classes of malicious buffer overflow attacks when combined with a supported operating system.
- Intel Trusted Execution Technology provides enhanced security through hardware-based resistance to malicious software attacks, allowing an application to run in its own isolated space, protected from all other software running on a system.

Energy efficiency

The x3750 M4 offers the following energy-efficiency features to save energy, reduce operational costs, and increase energy availability:

- Energy-efficient planar components help lower operational costs.

- Highly efficient 750 W DC, 900 W AC, and 1400 W AC power supplies. 80 PLUS Platinum certification at high-voltage AC.
- The Intel Xeon processor E5-4600 v2 product family offers better performance over the previous generation E5-4600, although it fits into the same TDP limits.
- Intel Intelligent Power Capability powers individual processor elements on and off as needed to reduce power draw.
- Low-voltage Intel Xeon processors draw less energy to satisfy the demands of power and thermally constrained data centers and telecommunication environments.
- Low-voltage 1.35 V DDR3 memory RDIMMs consume 19% less energy compared to 1.5 V DDR3 RDIMMs.
- Solid-state drives (SSDs) consume as much as 80% less power than traditional spinning 2.5-inch HDDs.
- The server uses hexagonal ventilation holes, which are a part of Calibrated Vectors Cooling™ technology. Hexagonal holes can be grouped more densely than round holes, providing more efficient airflow through the system.
- IBM Systems Director Active Energy Manager™ provides advanced data center power notification and management to help achieve lower heat output and reduced cooling needs.

Locations of key components and connectors

Figure 2 shows the front of the server.

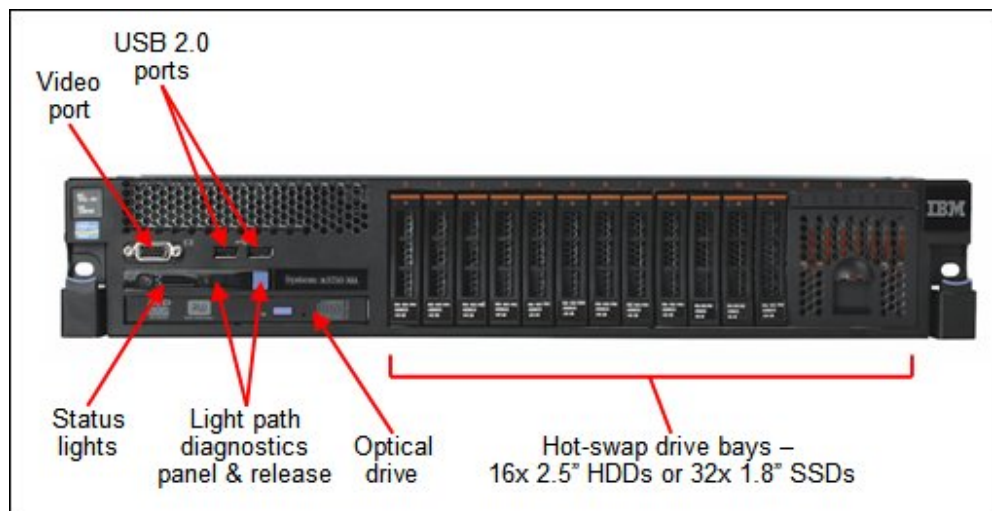

Figure 2. Front view of the System x3750 M4

Figure 3 shows the rear of the server.

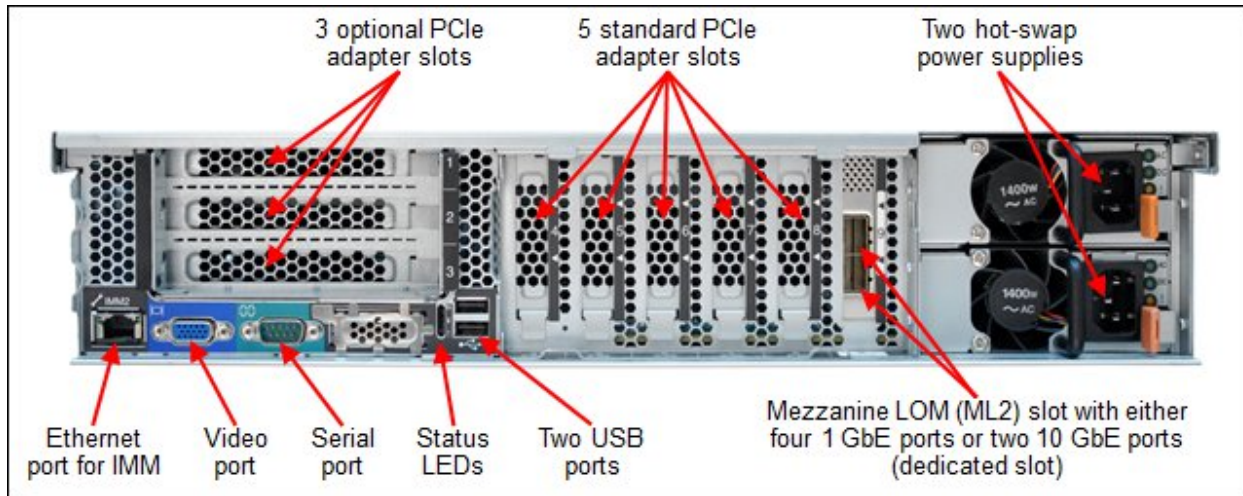

Figure 3. Rear view of the System x3750 M4 (machine type 8752)

Figure 4 shows the locations of key components inside the server.

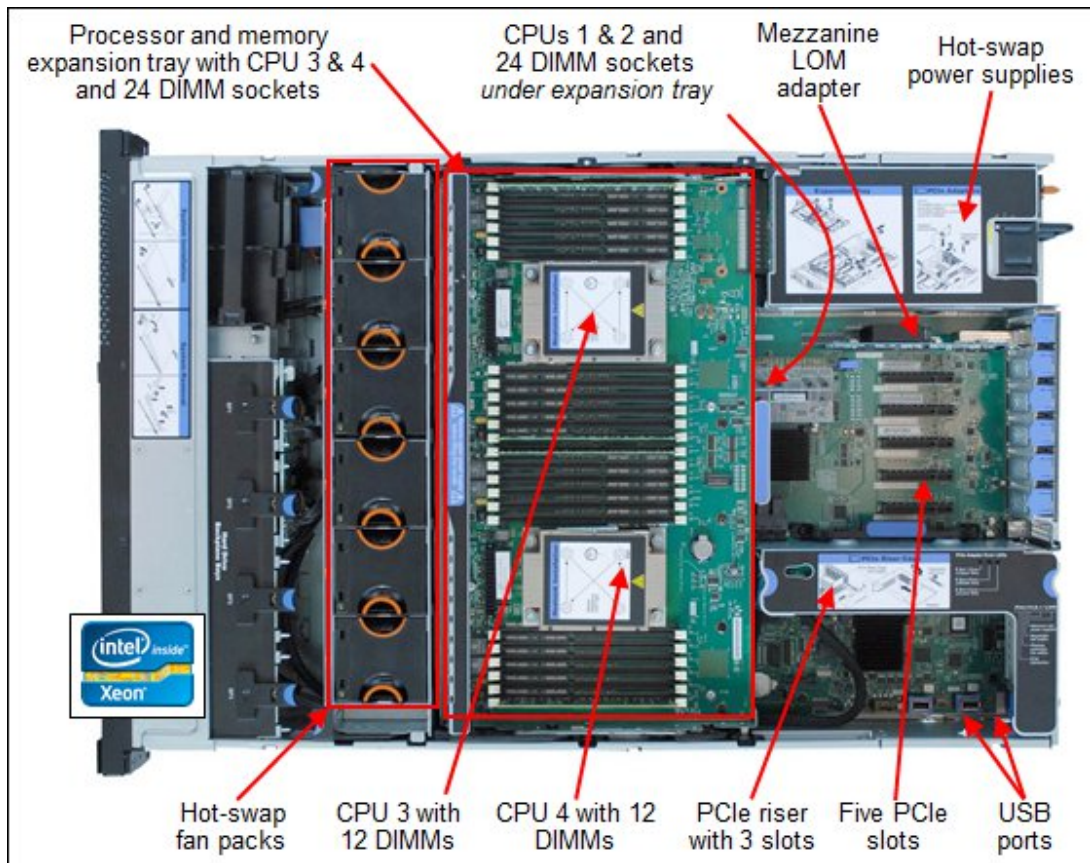

Figure 4. Inside view of the System x3750 M4 (machine type 8752)

Standard specifications

Table 1 lists the standard specifications.

Table 1. Standard specifications

Components	Specification
Machine type	8752
Form factor	2U rack
Processor	Up to four Intel Xeon E5-4600 v2 processors, each with 12 cores (2.4 GHz), ten cores (up to 2.4 GHz), eight cores (up to 3.3 GHz), six cores (2.6 GHz), or four cores (2.2 GHz). Up to 1866 MHz memory speed. Up to 30 MB L3 cache per processor. Two processor sockets on the system board and two processors on the processor and memory expansion tray (standard on most models). Two QPI links up to 8.0 GTps each.
Chipset	Intel C600 series.
Memory	Up to 48 DIMM sockets (12 DIMMs per processor). RDIMMs and LRDIMMs (Load Reduced DIMMs) are supported, but memory types cannot be intermixed. The memory speed is up to 1866 MHz. There are 24 DIMM sockets on the system board. There are an additional 24 DIMM sockets on the processor and memory expansion tray (standard on most models).
Memory maximums	With RDIMMs: Up to 768 GB with 48x 16 GB RDIMMs and four processors. With LRDIMMs: Up to 1.5 TB with 48x 32 GB LRDIMMs and four processors.
Memory protection	ECC, Chipkill (for x4-based memory DIMMs), memory mirroring, and memory sparing.
Disk drive bays	Up to 16 2.5-inch hot-swap SAS/SATA bays or up to 32 1.8-inch hot-swap solid-state drive (SSD) eXFlash bays. Drive bays can be in any combination of four 2.5-inch drives or eight 1.8-inch eXFlash SSD drives.
Maximum internal storage	Up to 28.8 TB with 1.8 TB 2.5" SAS HDDs, Up to 25.6 TB with 1.6 TB 2.5" SSDs, up to 16 TB with 1 TB 2.5" NL SAS/SATA HDDs. Intermix of SAS/SATA supported.
RAID support	RAID 0, 1, 10 with integrated ServerRAID M5210e with LSI SAS3108 RAID on Chip (ROC) controller. Optional upgrades to RAID 5 and 50 are available (1GB cache no battery, or 1 or 2 GB flash-backed cache). Optional upgrades to RAID 6 and 60 when cache is also installed.
Optical drive bays	There is one bay for an optional Multiburner drive.
Tape drive bays	None internal. Use a supported external tape drive.
Network interfaces	Dedicated mezzanine LOM adapter slot for a choice of 2-port 10 GbE (RJ45 or SFP+) or 4-port 1 GbE controller. One port can optionally be shared with the IMM2 management processor. Standard models include Intel I350-T4 ML2 Quad Port GbE Adapter (I350 based) except model C2x which includes Broadcom NetXtreme II ML2 Dual Port 10GbaseT (BCM57712 based)
Ports	Front: Two USB 2.0 and one DB-15 video on front. Rear: Two USB 2.0, one DB-15 video, one DB-9 serial, one RJ-45 systems management ports, mezzanine LOM adapter with either four 1 GbE network ports or two 10 GbE (RJ-45 or SFP+) network ports in dedicated slot. Internal: Two internal USB ports (for the embedded hypervisor).

Components	Specification
PCI Expansion slots	Up to eight slots, five on the system board, up to three on an optional riser card. Slots 1, 2, and 3 are physically x16 slots. Alternative 2-slot riser with one x16 and one x8 slot also available. The slots are as follows: <ul style="list-style-type: none"> • Slot 1: PCIe 3.0 x8; full-height, half-length (optional with riser card, requires processor 2) • Slot 2: PCIe 3.0 x8; full-height, half-length (optional with riser card, requires processor 2) • Slot 3: PCIe 3.0 x8; full-height, half-length (optional with riser card, requires processor 2) • Slot 4: PCIe 3.0 x8; low profile (requires processor 2) • Slot 5: PCIe 3.0 x8; low profile (requires processor 2) • Slot 6: PCIe 3.0 x8; low profile • Slot 7: PCIe 3.0 x8; low profile • Slot 8: PCIe 3.0 x8; low profile
Cooling	Calibrated Vectored Cooling with up to six N+N redundant hot swap fans (all six standard); each fan has two rotors.
Power supply	Up to two hot-swap redundant AC power supplies (80 PLUS Platinum certification). Standard models use 900W supplies; available 1400W AC and 750W DC options. Second power supply requires processor expansion tray (88Y7365) or the power interposer card (88Y7367) installed.
Video	Matrox G200eR2 with 16 MB memory integrated into the IMM2. Maximum resolution is 1600x1200 at 75 Hz with 16 M colors.
Hot-swap parts	Drives, power supplies, and fans.
Systems management	UEFI, Integrated Management Module II (IMM2), Predictive Failure Analysis, Light Path Diagnostics, Automatic Server Restart, IBM Systems Director and Active Energy Manager, and the ServerGuide. IMM Advanced Upgrade software feature for remote presence are standard with the x3750 M4.
Security features	Power-on password, administrator's password, Trusted Platform Module (TPM).
Operating systems supported	Microsoft Windows Server 2008 R2, 2012, 2012 R2; RHEL 6 x64; SLES 11 x64; VMware vSphere 5.1, 5.5
Limited warranty	Three-year customer-replaceable unit and onsite limited warranty with 9x5 next business day (NBD).
Service and support	Optional service upgrades are available through ServicePac® offerings: Four-hour or two-hour response time, eight-hour fix time, one-year or two-year warranty extension, remote technical support for Lenovo hardware and some Lenovo and third-party applications.
Dimensions	Height: 86 mm (3.4 in.), width: 445 mm (17.5 in.), depth: 746 mm (29.4 in.)
Weight	Minimum configuration: 25 kg (55 lb.), maximum: 30 kg (65 lb.)

The x3750 M4 servers are shipped with the following items:

- Statement of Limited Warranty
- Important Notices
- Rack Installation Instructions
- Documentation CD that contains the *Installation and User's Guide*
- System x Gen-III Slides Kit
- System x Gen-III Cable Management Arm (CMA)
- 2.8 m (9.2 ft.) C13-C14 power cord (one for models with one power supply, and two for models with two power supplies)

Standard models

Table 2 lists the standard models.

Table 2. Standard models

Model	Intel Xeon processor* (four maximum)**	Memory** (RDIMMs)	RAID controller	Hot-swap disk bays	Disks	PCIe	GbE‡	Power supply
Models announced March 2014								
8752-A1x	2x E5-4627 v2 8C 3.3GHz 16MB 1866MHz 130W	2x 8 GB 1866 MHz	M5210e	4x 2.5" 16 max	Open	5 / 8	4x 1GbE	1x 900W
8752-A2x	1x E5-4603 v2 4C 2.2GHz 10MB 1333MHz 95W	1x 8 GB** (1333 MHz)§	M5210e	Open	Open	5 / 8	4x 1GbE	1x 900W
8752-A3x	2x E5-4607 v2 6C 2.6GHz 15MB 1333MHz 95W	2x 8 GB (1333 MHz)§	M5210e	4x 2.5" 16 max	Open	5 / 8	4x 1GbE	1x 900W
8752-B1x	2x E5-4610 v2 8C 2.3GHz 16MB 1600MHz 95W	2x 8 GB 1600 MHz	M5210e	4x 2.5" 16 max	Open	5 / 8	4x 1GbE	1x 900W
8752-B2x	2x E5-4620 v2 8C 2.6GHz 20MB 1600MHz 95W	2x 8 GB 1600 MHz	M5210e	8x 1.8" 32 max	Open	8 / 8	4x 1GbE	1x 900W
8752-C1x	2x E5-4640 v2 10C 2.2GHz 20MB 1866MHz 95W	2x 8 GB 1600 MHz	M5210e (1GB,F,R5)†	4x 2.5" 16 max	Open	8 / 8	4x 1GbE	1x 900W
8752-C2x	2x E5-4650 v2 10C 2.4GHz 25MB 1866MHz 95W	2x 8 GB 1600 MHz	M5210e (1GB,F,R5)†	4x 2.5" 16 max	Open	5 / 8	2x 10GbE‡	1x 900W

* Processor detail: Processor quantity and model, cores, core speed, L3 cache, memory speed, and power consumption.

** All models except for 8752-A2x include the processor and memory expansion tray containing sockets for processors 3 and 4 and 24 DIMMs. For model A2x, order part number 88Y7365.

‡ Model 8752-C2x includes the Broadcom NetXtreme II ML2 Dual Port 10GbaseT adapter, 00D2026. All other models include the Intel I350-T4 ML2 Quad Port GbE Adapter, 00D1998

§ For these models, the standard DIMM is rated at 1600 MHz, but operates at up to 1333 MHz to match the processor memory speed

† Models C1x and C2x include the ServeRAID M5200 Series 1GB Flash/RAID 5 Upgrade (part number 47C8660) which is a 1 GB flash-backed cache with support for RAID 5.

See the Standards specifications section for information about the standard features of the server.

Processor options

The x3750 M4 supports the processor options listed in Table 3. The server supports up to four processors. Two processors are installed in sockets on the system board. Processors 3 and 4 are installed on the processor and memory expansion tray. Most models (with the exception of A2x, as listed in Table 2) have the expansion tray installed as standard. For model A2x, order part number 88Y7365 for the processor and memory expansion tray.

The following processor quantities are supported:

- One processor, installed in socket 1
- Two processors, installed in sockets 1 and 2
- Four processors, installed in all four sockets

Table 3 also shows which server models have each processor standard. If there is no corresponding *where-used* model for a particular processor, this processor is only available through CTO.

Table 3. Processor options

Part number	Feature code*	Description	Models where used
88Y7365	A29Z	System x3750 M4 processor and memory expansion tray	All except A2x
00D1948	A43K / A43U	Intel Xeon E5-4603 v2 4C 2.2GHz 10MB 1333MHz 95W	8752-A2x
00D1953	A43L / A43V	Intel Xeon E5-4607 v2 6C 2.6GHz 15MB 1333MHz 95W	8752-A3x
00D1958	A43M / A43W	Intel Xeon E5-4610 v2 8C 2.3GHz 16MB 1600MHz 95W	8752-B1x
00D1963	A43N / A43X	Intel Xeon E5-4620 v2 8C 2.6GHz 20MB 1600MHz 95W	8752-B2x
00D1978	A43R / A440	Intel Xeon E5-4627 v2 8C 3.3GHz 16MB 1866MHz 130W	8752-A1x
00D0574	A452 / A453	Intel Xeon E5-4624L v2 10C 1.9GHz 25MB 1866MHz 70W	-
00D1968	A43P / A43Y	Intel Xeon E5-4640 v2 10C 2.2GHz 20MB 1866MHz 95W	8752-C1x
00D1973	A43Q / A43Z	Intel Xeon E5-4650 v2 10C 2.4GHz 25MB 1866MHz 95W	8752-C2x
00D1988	A43T / A442	Intel Xeon E5-4657L v2 12C 2.4GHz 30MB 1866MHz 115W	-

* The first feature code corresponds to the first processor installed; the second feature is for all additional processors.

Memory options

Lenovo DDR3 memory is compatibility-tested and tuned for optimal System x performance and throughput. Lenovo memory specifications are integrated into the light path diagnostics for immediate system performance feedback and optimum system uptime. From a service and support standpoint, Lenovo memory automatically assumes the system warranty.

The System x3750 M4 supports DDR3 memory. The server supports up to 48 DIMMs when four processors are installed, with 12 DIMMs for each processor. There are 24 DIMM sockets (for processors 1 and 2) on the system board. The remaining DIMM sockets (for processors 3 and 4) are on the processor and memory expansion tray. Each processor has four memory channels, and there are three DIMMs per channel.

The x3750 M4 memory system has been carefully tuned so that the server supports higher memory frequencies than the Intel processor specification. You can, for example, use low-voltage DIMMs but still operate them at the rated speed.

Table 4 lists the memory options that are available for the x3750 M4 server.

Table 4. Memory options

Part number	Feature code	Description	Maximum supported	Models where used
RDIMMs - 1866 MHz				
00D5048	A3QL	16GB (1x16GB, 2Rx4, 1.5V) PC3-14900 CL13 ECC DDR3 1866MHz LP RDIMM	48 (12 per processor)	-
00D5032	A3QG	8GB (1x8GB, 1Rx4, 1.5V) PC3-14900 CL13 ECC DDR3 1866MHz LP RDIMM	48 (12 per processor)	8752-A1x
00D5020	A3QD	4GB (1x4GB, 1Rx4, 1.5V) PC3-14900 CL13 ECC DDR3 1866MHz LP RDIMM	48 (12 per processor)	-
RDIMMs - 1600 MHz				
46W0672	A3QM	16GB (1x16GB, 2Rx4, 1.35V) PC3L-12800 CL11 ECC DDR3 1600MHz LP RDIMM	48 (12 per processor)	-
00D5036	A3QH	8GB (1x8GB, 1Rx4, 1.35V) PC3L-12800 CL11 ECC DDR3 1600MHz LP RDIMM	48 (12 per processor)	All other 8752 models
00D5024	A3QE	4GB (1x4GB, 1Rx4, 1.35V) PC3L-12800 CL11 ECC DDR3 1600MHz LP RDIMM	48 (12 per processor)	-
LRDIMMs				
46W0761	A47K	32GB (1x32GB, 4Rx4, 1.5V) PC3-14900 CL13 ECC DDR3 1866MHz LP LRDIMM	48 (12 per processor)	-

The following rules apply when selecting the memory configuration:

- The server supports RDIMMs and LRDIMMs. UDIMMs are not supported.
- Mixing different types of memory (RDIMMs and LRDIMMs) is not supported.
- Mixing 1.5 V and 1.35 V DIMMs in the same server is supported; in such a case, all DIMMs operate at 1.5 V.
- The maximum number of ranks per one channel is eight (with the exception of Load Reduced DIMMs, where more than eight ranks are supported, because one quad-rank LRDIMM provides the same electrical load on a memory bus as a single-rank RDIMM).
- The maximum quantity of DIMMs that can be installed in the server depends on the number of processors installed. The table shows the maximum when all four processors are installed. When two processors are installed, the maximum quantity supported is a half of the quantity that is shown.
- All DIMMs in the server operate at the same speed, which is determined as the lowest value of:
 - Memory speed that is supported by the specific processor.
 - Lowest of maximum operating speeds for selected memory configuration that depends on rated speed, operating voltage, and quantity of DIMMs per channel, as shown under "Max. operating speed" section in the next table.

Table highlighting

- The memory speed entries highlighted in **bold text** in Table 5 indicate that the System x3750 M4 supports higher memory frequencies than the Intel processor specification. In some instances, this configuration also results larger memory capacity that the specification recommends.
- Tables cells highlighted with a gray background indicate when the specific combination of DIMM voltage and number of DIMMs per channel still allows the DIMMs to operate at rated speed

Table 5. Maximum memory speeds

DIMM specification	RDIMM						LRDIMM
	Single-rank DIMMs			Dual-rank DIMMs			Quad-rank LRDIMMs
Part numbers	00D5024 (4 GB) 00D5036 (8 GB)		00D5020 (4 GB) 00D5032 (8 GB)	46W0672(16 GB)		00D5048 (16 GB)	46W0761 (32 GB)
Rated speed	1600 MHz		1866 MHz	1600 MHz		1866 MHz	1866 MHz
Rated voltage	1.35 V		1.5 V	1.35 V		1.5 V	1.5 V
Operating voltage	1.35 V	1.5 V	1.5 V	1.35 V	1.5 V	1.5 V	1.5 V
Max. qty supported*	48	48	48	48	48	48	48
Max. DIMM capacity	8 GB	8 GB	8 GB	16 GB	16 GB	16 GB	32 GB
Max. mem. capacity	384 GB	384 GB	384 GB	768 GB	768 GB	768 GB	1.5 TB
Max memory at maximum speed	256 GB	256 GB	256 GB	512 GB	768 GB	512 GB	1.0 TB
Max operating speed (MHz)							
1 DIMM per channel	1333 MHz	1600 MHz	1866 MHz	1333 MHz	1600 MHz	1866 MHz	1866 MHz
2 DIMMs per channel	1600 MHz	1600 MHz	1866 MHz	1600 MHz	1600 MHz	1866 MHz	1866 MHz
3 DIMMs per channel	1066 MHz	1333 MHz	1333 MHz	1066 MHz	1333 MHz	1333 MHz	1333 MHz

* Maximum quantity supported is shown for four processors installed. When two processors are installed, the maximum quantity supported is a half of the quantity that is shown. When one processor is installed, the quantity is one quarter of that shown.

The following memory protection technologies are supported:

- ECC
- Chipkill (for x4-based memory DIMMs, look for "x4" in the DIMM description)
- Memory mirroring
- Memory rank sparing

If memory mirroring is used, then DIMMs must be installed in pairs (minimum of one pair per CPU), and both DIMMs in a pair must be identical in type and size.

If memory rank sparing is used, then a minimum of one quad-rank DIMM or two single-rank or dual-rank DIMMs must be installed per populated channel (the DIMMs do not need being identical). In rank sparing mode, one rank of a DIMM in each populated channel is reserved as spare memory. The size of a rank varies depending on the DIMMs installed.

Internal storage

The server can support up to 16x 2.5-inch drives, up to 32x 1.8-inch drives, or a combination of both 2.5-inch and 1.8-inch hot-swap drives, using the supported SAS/SATA backplane configurations. The server supports 2.5-inch hot-swap SAS or hot-swap SATA hard disk drives, 2.5-inch hot-swap SATA solid-state drives, or 1.8-inch hot-swap SATA solid-state drives. You can mix drives in the same server if you do not mix drives on the same array.

Backplanes

The System x3750 M4 server supports various internal storage configurations based on four different backplanes:

- 4-drive backplane for 2.5-inch drives: Up to four backplanes can be installed, each requiring one SAS connection to a supported controller. One RAID controller can connect to two of these backplanes.
- 8-drive backplane for 2.5-inch drives: Up to two backplanes can be installed, each requiring two SAS connections. One RAID controller per backplane.
- 8-drive backplane with a SAS expander for 2.5-inch drives: Use with the other 2.5-inch drive backplanes (8-drive or one 4-drive or two 4-drive backplanes) which will result in being able to connect up to 16 2.5-inch drive bays to the one RAID controller.
- 8-drive backplane for 1.8-inch solid-state drives (eXFlash Pack): Up to four backplanes can be installed, each requiring two SAS connections. One RAID controller per backplane. Cannot be connected to the 8-drive backplane with a SAS expander.

When building drive backplane configurations, all 1.8-inch SSD drive backplanes must be installed to the right of all 2.5-inch HDD or 2.5-inch SSD drive backplanes (when looking at the front of the server). Every four drives uses a SAS signal cable except when the 8-drive backplane with SAS expander is used. When the 8-drive backplane with SAS expander is used, the other backplanes connect to the SAS expander backplane with the supplied cables and then the SAS expander backplane is connected to the single RAID controller with two cables. All backplane options include the necessary cables.

See the *System x3750 M4 Installation and Service Guide* for a description of all supported backplane combinations.

Standard models (all models except A2x) ship with at least one backplane; see Table 2 for details. Table 6 shows the backplane options that are available for a x3750 M4 server.

Table 6. Internal storage expansion options

Part number	Feature code	Name	Maximum supported
00D2020	A4XA	4x 2.5" HS SAS/SATA/SSD HDD Backplane	4*
00D2022	A4XC	8x 2.5" HS SAS/SATA/SSD HDD Backplane	2
00D2011	A4XD	8x 2.5" HS SAS/SATA/SSD HDD Backplane with controller expansion (SAS expander)	1**
00D2024	A4XB	eXFlash 8x 1.8" HS SAS SSD Backplane	4

* When a server is ordered via CTO, only one 4-drive backplane can be selected. If the order has more than 4 drive bays, 8-drive backplanes will be selected instead.

** Only one backplane with SAS expander (00D2011) can be installed in a server and can be used connected to a single 8-drive backplane (00D2022), a single 4-drive backplane (00D2020), or two 4-drive backplanes (00D2020). The SAS expander backplane cannot be used with the eXFlash backplane.

Controllers for internal storage

Table 7 lists the RAID controllers and SAS HBAs used for the internal disk storage of the x3750 M4 server.

Table 7. RAID controllers for internal storage

Part number	Feature code	Description	Maximum supported	Models where used
None	A3QA	SeveRAID M5210e SAS/SATA Controller	1 (integrated)	All
46C9110	A3YZ	ServeRAID M5210 SAS/SATA Controller	3	-
46C9114	A45W	ServeRAID M1215 SAS/SATA Controller	3	-
47C8675	A3YY	N2215 SAS/SATA HBA for System x	3	-

The integrated ServeRAID M5210e SAS/SATA controller in a chip on the system board for machine type 8752. It has the following specifications:

- LSI SAS3108 RAID on Chip (ROC) controller.
- Eight internal SAS/SATA ports.
- Two internal x4 HD Mini-SAS connectors (SFF-8643).
- PCI Express 3.0 x8 host interface.
- Support for RAID 0, 1, and 10 standard
- Support for RAID 5, 50, 6, and 60 with optional upgrades.
- Optional onboard data cache: 1 GB (no battery backup), or 1 or 2 GB with flash backup
- Optional support for self-encrypting drives (SEDs) with MegaRAID SafeStore.

Note: The drives and backplanes currently supported in the x3750 M4 operate at 6 Gbps speeds, so the M5210e will also operate at 6 Gbps.

For more information, see the list of Lenovo Press Product Guides in the RAID adapters category: <http://lenovopress.com/systemx/raid>

Note: The supported adapters for internal storage need to be installed in slots 1, 2 and 3 because of cable routing requirements. One of the supported riser cards must be installed. These slots also require that Processor 2 be installed.

Table 8 lists the optional upgrades supported with the ServeRAID controllers.

Table 8. RAID controller upgrades

Part number	Feature code	Description	Upgrade type	Maximum supported
47C8656	A3Z0	ServeRAID M5200 Series 1GB Cache/RAID 5 Upgrade	Hardware	4
47C8660	A3Z1	ServeRAID M5200 Series 1GB Flash/RAID 5 Upgrade	Hardware	4
47C8664	A3Z2	ServeRAID M5200 Series 2GB Flash/RAID 5 Upgrade	Hardware	4
47C8668	A3Z3	ServeRAID M5200 Series 4GB Flash/RAID 5 Upgrade	Hardware	4
47C8706	A3Z5	ServeRAID M5200 Series RAID 6 Upgrade-FoD	FoD	1*
47C8708	A3Z6	ServeRAID M5200 Series Zero Cache/RAID 5-FoD	FoD	1
47C8710	A3Z7	ServeRAID M5200 Series Performance Accelerator-FoD	FoD	1*
47C8712	A3Z8	ServeRAID M5200 Series SSD Caching Enabler-FoD	FoD	1*
00AE930	A5H5	ServeRAID M1200 Zero Cache/RAID 5 Upgrade for Systems FOD	FoD	1

* These M5200 upgrades require one of the cache upgrades (47C8656, 47C8660, 47C8664, or 47C8668)

Internal drive options

Table 9 lists the hard disk drive options for the internal disk storage of the x3750 M4 server.

Table 9. Disk drive options for internal disk storage

Part number	Feature code	Description	Maximum supported
2.5-inch 10K SAS Hot-Swap HDDs			
90Y8877	A2XC	300GB 10K 6Gbps SAS 2.5" SFF G2HS HDD	16
90Y8872	A2XD	600GB 10K 6Gbps SAS 2.5" SFF G2HS HDD	16
81Y9650	A282	900GB 10K 6Gbps SAS 2.5" SFF HS HDD	16
00AD075	A48S	1.2TB 10K 6Gbps SAS 2.5" G2HS HDD	16
00NA441	ASCD	1.8TB 10K 6Gbps SAS 2.5" G2HS 512e HDD	16
2.5-inch 15K SAS Hot-Swap HDDs			
90Y8926	A2XB	146GB 15K 6Gbps SAS 2.5" SFF G2HS HDD	16
81Y9670	A283	300GB 15K 6Gbps SAS 2.5" G2HS HDD	16
00AJ300	A4VB	600GB 15K 6Gbps SAS 2.5" G2HS HDD	16
2.5-inch NL SATA Hot-Swap HDDs			
81Y9722	A1NX	250GB 7.2K 6Gbps NL SATA 2.5" SFF HS HDD	16
81Y9726	A1NZ	500GB 7.2K 6Gbps NL SATA 2.5" SFF HS HDD	16
81Y9730	A1AV	1TB 7.2K 6Gbps NL SATA 2.5" SFF HS HDD	16
2.5-inch NL SAS Hot-Swap HDDs			
90Y8953	A2XE	500GB 7.2K 6Gbps NL SAS 2.5" SFF G2HS HDD	16
81Y9690	A1P3	1TB 7.2K 6Gbps NL SAS 2.5" SFF HS HDD	16
2.5-inch SAS Hot-Swap SEDs			
90Y8944	A2ZK	146GB 15K 6Gbps SAS 2.5" SFF G2HS SED	16
90Y8913	A2XF	300GB 10K 6Gbps SAS 2.5" SFF G2HS SED	16
90Y8908	A3EF	600GB 10K 6Gbps SAS 2.5" SFF G2HS SED	16
81Y9662	A3EG	900GB 10K 6Gbps SAS 2.5" SFF G2HS SED	16
00AD085	A48T	1.2TB 10K 6Gbps SAS 2.5" G2HS SED	16
00NA476	ASCF	1.8TB 10K 6Gbps SAS 2.5" G2HS 512e SED	16
SAS-SSD hybrid drives			
00AD102	A4G7	600GB 10K 6Gbps SAS 2.5" G2HS Hybrid	16
2.5-inch SSDs - Enterprise			
49Y6134	A3EY	400GB SAS 2.5" MLC HS Enterprise SSD	16
49Y6139	A3F0	800GB SAS 2.5" MLC HS Enterprise SSD	16
49Y6195	A4GH	1.6TB SAS 2.5" MLC HS Enterprise SSD	16
41Y8331	A4FL	S3700 200GB SATA 2.5" MLC HS Enterprise SSD	16
41Y8336	A4FN	S3700 400GB SATA 2.5" MLC HS Enterprise SSD	16
41Y8341	A4FQ	S3700 800GB SATA 2.5" MLC HS Enterprise SSD	16
2.5-inch SSDs - Enterprise Value			
00AJ000	A4KM	S3500 120GB SATA 2.5" MLC HS Enterprise Value SSD	16
00AJ005	A4KN	S3500 240GB SATA 2.5" MLC HS Enterprise Value SSD	16
00AJ010	A4KP	S3500 480GB SATA 2.5" MLC HS Enterprise Value SSD	16
00AJ015	A4KQ	S3500 800GB SATA 2.5" MLC HS Enterprise Value SSD	16

Part number	Feature code	Description	Maximum supported
00FN268	A5U4	S3500 1.6TB SATA 2.5" MLC HS Enterprise Value SSD	16
2.5-inch SSDs - Entry			
00FN298	AS0D	240GB SATA 2.5" MLC HS Entry SSD	16
00FN327	AS0E	480GB SATA 2.5" MLC HS Entry SSD	16
00FN332	AS0F	960GB SATA 2.5" MLC HS Entry SSD	16
1.8-inch SSDs - Enterprise			
49Y6119	A3AN	200GB SATA 1.8" MLC Enterprise SSD	32
41Y8366	A4FS	S3700 200GB SATA 1.8" MLC Enterprise SSD	32
41Y8371	A4FT	S3700 400GB SATA 1.8" MLC Enterprise SSD	32
1.8-inch SSDs - Enterprise Value			
00AJ040	A4KV	S3500 80GB SATA 1.8" MLC Enterprise Value SSD	32
00AJ045	A4KW	S3500 240GB SATA 1.8" MLC Enterprise Value SSD	32
00AJ050	A4KX	S3500 400GB SATA 1.8" MLC Enterprise Value SSD	32
00AJ455	A58U	S3500 800GB SATA 1.8" MLC Enterprise Value SSD	32

Internal backup units

The server does not support any internal backup units, such as tape drives or RDX drives.

Optical drives

The server supports the optical drive options listed in Table 10.

Table 10. Optical drives

Part number	Feature code	Description	Maximum supported	Models where used
46M0902	4163	UltraSlim Enhanced SATA Multi-Burner	1	-

The UltraSlim Enhanced SATA Multi-Burner (46M0902) supports the following media and speeds for reading:

- CD-ROM 24X
- CD-DA (DAE) 20X
- CD-R 24X
- CD-RW 24X
- DVD-ROM (single layer) 8X
- DVD-ROM (dual layer) 8X
- DVD-R (4.7 GB) 6X
- DVD-R DL 4X
- DVD+R 6X
- DVD+R DL 4X
- DVD-RW (4.7 GB) 4X
- DVD+RW 4X
- DVD-RAM (4.7/9.4 GB) 4X

The drive also supports the following media and speeds for writing:

- CD-R 24X
- CD-RW 4X
- High Speed CD-RW 10X
- Ultra Speed CD-RW 16X
- Ultra Speed Plus CD-RW 16X
- DVD-R 8X
- DVD-R DL 6X
- DVD+R 8X
- DVD+R DL 6X
- DVD-RW 6X
- DVD+RW 8X
- DVD-RAM 5X

I/O expansion options

The server supports up to eight PCIe slots, not including the mezzanine LOM slot. Five slots are on the system board and three are through a riser card. A riser card is standard on some models as shown in the table below. It is optional on all other models. The use of slots 1 - 5 require processor 2 to be installed. Table 11 lists the ordering information for the riser cards.

Table 11. PCI riser card options

Part number	Feature code	Description	Standard models where used	Maximum supported
88Y7371	A2A1	x3750 M4 PCIe 3 x8 riser	B2x, C1x	1
00D2009	A419	x3750 M4 PCIe 1x16 and 1x8 riser	-	1

The three slots on the PCIe 3 x8 riser are as follows:

- Slot 1: PCIe 3.0 x8 (x16 mechanical): Full-height, half-length (requires processor 2)
- Slot 2: PCIe 3.0 x8 (x16 mechanical): Full-height, half-length (requires processor 2)
- Slot 3: PCIe 3.0 x8 (x16 mechanical): Full-height, half-length (requires processor 2)

The two slots on the PCIe 1x16 and 1x8 riser are as follows:

- Slot 1: PCIe 3.0 x16: Full-height, half-length (requires processor 2)
- Slot 2: PCIe 3.0 x8 (x16 mechanical): Full-height, half-length (requires processor 2)
- Slot 3: Not present

The five standard slots on the system board are as follows:

- Slot 4: PCIe 3.0 x8: Low profile, half-length (requires processor 2)
- Slot 5: PCIe 3.0 x8: Low profile, half-length (requires processor 2)
- Slot 6: PCIe 3.0 x8: Low profile, half-length
- Slot 7: PCIe 3.0 x8: Low profile, half-length
- Slot 8: PCIe 3.0 x8: Low profile, half-length

Network adapters

The x3750 M4, machine type 8752 (using Intel Xeon E5-4600 v2 processors) offers a dedicated Mezzanine LOM slot for integrated networking. In addition to the usual networking functions for the installed operating system, this adapter also supports shared access to the IMM2 service processor if so enabled in UEFI. Table 12 lists the supported ML2 adapters that are installed in this slot. Only one adapter is supported.

Table 12. Mezzanine LOM network adapters

Part number	Feature code	Description	Maximum supported
10 Gb Ethernet			
00D2026	A40S	Broadcom NetXtreme II ML2 Dual Port 10GbaseT for System x	1*
00D2028	A40T	Broadcom NetXtreme II ML2 Dual Port 10GbE SFP+ for System x	1*
00D1996	A40Q	Emulex VFA5 ML2 Dual Port 10GbE SFP+ Adapter for System x	1*
00D8544	A4NZ	Emulex VFA5 ML2 FCoE/iSCSI License for System x (FoD) (FCoE/iSCSI upgrade for 00D1996)	1
00D1994	A40P	Intel X540 ML2 Dual Port 10GbaseT Adapter for System x	1*
94Y5200	AS74	Intel X710 ML2 4x10GbE SFP+ Adapter for System x	1*
00FP650	A5RK	Mellanox ConnectX-3 Pro ML2 2x40GbE/FDR VPI Adapter	1*
1 Gb Ethernet			
00D1998	A40R	Intel I350-T4 ML2 Quad Port GbE Adapter for System x	1*

* These ML2 adapters occupy the same dedicated slot and are mutually exclusive.

Table 13 lists additional supported network adapters that can be installed in the eight regular PCIe slots.

Table 13. Network adapters

Part number	Feature code	Description	Maximum supported#
40 Gb Ethernet / InfiniBand			
00D9550	A3PN	Mellanox ConnectX-3 40GbE / FDR IB VPI Adapter for System x	8
10 Gb Ethernet			
94Y5180	A4Z6	Broadcom NetXtreme Dual Port 10GbE SFP+ Adapter for System x	8
49Y7910	A18Y	Broadcom NetXtreme II Dual Port 10GBaseT Adapter for System x	8
44T1370	A5GZ	Broadcom NetXtreme 2x10GbE BaseT Adapter for System x	8
00D8540	A4M9	Emulex Dual Port 10GbE SFP+ VFA IIIr for System x	8
95Y3760	A2U2	Emulex VFA III/IIIr FCoE/iSCSI License for System x (FoD) (FCoE/iSCSI upgrade for 00D8540)	8
00JY830	A5UU	Emulex VFA5 2x10 GbE SFP+ Adapter and FCoE/iSCSI SW	8
00JY820	A5UT	Emulex VFA5 2x10 GbE SFP+ PCIe Adapter for System x	8
00JY824	A5UV	Emulex VFA5 FCoE/iSCSI SW for PCIe Adapter for System x (FoD) (FCoE/iSCSI upgrade for 00JY820)	8
49Y7960	A2EC	Intel X520 Dual Port 10GbE SFP+ Adapter for System x	8
49Y7970	A2ED	Intel X540-T2 Dual Port 10GBaseT Adapter for System x	8
81Y3520	AS73	Intel X710 2x10GbE SFP+ Adapter for System x	8
00D9690	A3PM	Mellanox ConnectX-3 10 GbE Adapter for System x	8
90Y4600	A3MR	QLogic 8200 Dual Port 10GbE SFP+ VFA for System x	8
00Y5624	A3MT	QLogic 8200 VFA FCoE/iSCSI License for System x (FoD) (FCoE/iSCSI upgrade for 90Y4600)	8
47C9952	A47H	Solarflare SFN5162F 2x10GbE SFP+ Performant Adapter	8
47C9960	A47J	Solarflare SFN6122F 2x10GbE SFP+ Onload Adapter	8
Gigabit Ethernet			
90Y9352	A2V3	Broadcom NetXtreme I Quad Port GbE Adapter for System x	8
90Y9370	A2V4	Broadcom NetXtreme I Dual Port GbE Adapter for System x	8
49Y4230	5767	Intel Ethernet Dual Port Server Adapter I340-T2 for System x	8
49Y4240	5768	Intel Ethernet Quad Port Server Adapter I340-T4 for System x	8
00AG500	A56K	Intel I350-F1 1xGbE Fiber Adapter for System x	8
00AG510	A56L	Intel I350-T2 2xGbE BaseT Adapter for System x	8
00AG520	A56M	Intel I350-T4 4xGbE BaseT Adapter for System x	8

Maximum quantity is achieved with processor 2 installed and the 3-slot riser card (88Y7371). With one processor, the maximum quantity is three (this maximum does not apply to the 10 Gb cards in the dedicated slot).

For more information, see the list of Lenovo Press Product Guides in the Networking adapters category:
<http://lenovopress.com/systemx/networkadapters>

Storage HBAs and external RAID controllers

Table 14 lists storage HBAs supported by x3750 M4 server. The maximum quantity is achieved with processor 2 and the 3-slot riser card (88Y7371) installed. With one processor, the maximum quantity is three (this configuration does not apply to the 10 Gb cards in the dedicated slot).

Table 14. Storage adapters

Part number	Feature code	Description	Maximum supported#
Fibre Channel - 16 Gbps			
81Y1675	A2XV	Brocade 16Gb FC Dual-port HBA for System x	8
81Y1668	A2XU	Brocade 16Gb FC Single-port HBA for System x	8
81Y1662	A2W6	Emulex 16Gb FC Dual-port HBA for System x	8
81Y1655	A2W5	Emulex 16Gb FC Single-port HBA for System x	8
00Y3341	A3KX	QLogic 16Gb FC Dual-port HBA for System x	8
00Y3337	A3KW	QLogic 16Gb FC Single-port HBA for System x	8
Fibre Channel - 8 Gbps			
46M6050	3591	Brocade 8Gb FC Dual-port HBA for System x	8
46M6049	3589	Brocade 8Gb FC Single-port HBA for System x	8
42D0494	3581	Emulex 8Gb FC Dual-port HBA for System x	8
42D0485	3580	Emulex 8Gb FC Single-port HBA for System x	8
42D0510	3579	QLogic 8Gb FC Dual-port HBA for System x	8
42D0501	3578	QLogic 8Gb FC Single-port HBA for System x	8
SAS			
46C9010	A3MV	N2125 SAS/SATA HBA for System x	8
47C8675	A3YY	N2215 SAS/SATA HBA for System x	3

Maximum quantity is achieved with processor 2 and the 3-slot riser card (88Y7371) installed. With one processor, the maximum quantity is three.

For more information, see the list of Lenovo Press Product Guides in the Host bus adapters category:
<http://lenovopress.com/systemx/hba>

The following table shows the RAID controllers and options for external disk storage expansion. The RAID controllers listed in the following table are supported with external expansion enclosures.

Table 15. RAID controller and options for external storage expansion enclosures

Part number	Feature code	Description	Maximum supported
81Y4478	A1WX	ServeRAID M5120 SAS/SATA Controller	4*
00AE938	A5ND	ServeRAID M5225-2GB SAS/SATA Controller	4
Upgrades for the ServeRAID M5120			
81Y4487	A1J4	ServeRAID M5100 Series 512MB Flash/RAID 5 Upgrade	1 per one M5120
81Y4559	A1WY	ServeRAID M5100 Series 1GB Flash/RAID 5 Upgrade	1 per one M5120
81Y4546	A1X3	ServeRAID M5100 Series RAID 6 Upgrade	1 per server
90Y4273	A2MC	ServeRAID M5100 Series SSD Performance Accelerator	1 per server
90Y4318	A2MD	ServeRAID M5100 Series SSD Caching Enabler	1 per server
Upgrades for the ServeRAID M5225			
47C8710	A3Z7	ServeRAID M5200 Series Performance Accelerator	1 per server
47C8706	A3Z5	ServeRAID M5200 Series RAID 6 Upgrade	1 per server
47C8712	A3Z8	ServeRAID M5200 Series SSD Caching Enabler	1 per server

* Each M5120 controller must have either the 512MB Flash/RAID 5 or the 1GB Flash/RAID 5 upgrade installed.

The ServeRAID M5120 SAS/SATA Controller has the following specifications:

- Eight external 6 Gbps SAS/SATA ports
- Two external x4 mini-SAS connectors (SFF-8088)
- Supports RAID levels 0, 1, and 10
- Supports RAID levels 5 and 50 with the required M5100 Series RAID 5 upgrades
- Supports RAID 6 and 60 with the optional M5100 Series RAID 6 Upgrade
- Supports 512 MB battery-backed cache or 512 MB or 1 GB flash-backed cache
- 6 Gbps throughput per port
- PCIe 3.0 x8 host interface
- Based on the LSI SAS2208 6 Gbps ROC controller
- Supports connectivity to the EXP2512 and EXP2524 storage expansion enclosures

Cache upgrade required: The ServeRAID M5120 SAS/SATA Controller ships standard without a cache. One of the available cache upgrades (81Y4487, 81Y4559, or 81Y4546) is required for the M5120 adapter operations, and it must be purchased together with the controller.

For more information about the ServeRAID M5120, see the Lenovo Press Product Guide at <http://lenovopress.com/tips0858>

The ServeRAID M5225 SAS/SATA Controller has the following specifications:

- Eight external 12 Gbps SAS/SATA ports
- Supports 12, 6, and 3 Gbps SAS and 6 and 3 Gbps SATA data transfer rates
- Two external x4 mini-SAS HD connectors (SFF-8644)
- Includes 2 GB flash-backed cache (standard)
- Supports RAID levels 0, 1, 5, 10, and 50 (standard)
- Supports RAID 6 and 60 with the optional M5200 Series RAID 6 Upgrade
- Supports optional M5200 Series Performance Accelerator and SSD Caching upgrades
- PCIe x8 Gen 3 host interface
- Based on the LSI SAS3108 12 Gbps ROC controller
- Supports connectivity to the EXP2512 and EXP2524 storage expansion enclosures

For more information about the ServeRAID M5225, see the Lenovo Press Product Guide at <http://lenovopress.com/tips1258>

PCIe SSD adapters

The server supports the High IOPS SSD adapters listed Table 15.

Note: The server supports a maximum quantity of three of the full-height adapters, which must be installed in slots 1, 2, and 3. These slots require the second processor and the 3-slot riser card, 88Y7371.

Table 16. SSD adapters

Part number	Feature code	Description	Maximum supported
90Y4377	A3DY	1.2TB High IOPS MLC Mono Adapter	7
90Y4397	A3DZ	2.4TB High IOPS MLC Duo Adapter	3
46C9078	A3J3	365GB High IOPS MLC Mono Adapter	7
46C9081	A3J4	785GB High IOPS MLC Mono Adapter	7
90Y4361	A3MZ*	300GB High IOPS MLC Modular Adapter	3
90Y4365	A3N0*	600GB High IOPS MLC Modular Adapter	3
90Y4369	A3N1*	800GB High IOPS MLC Modular Adapter	3
90Y4373	A3N2*	300GB High IOPS SLC Modular Adapter	3

* These modular adapters are not available through CTO or Special build. The adapter cannot be shipped installed and instead must be shipped in its option box and configured at the final installation location. For more information, see <http://ibm.com/support/entry/portal/docdisplay?indocid=SERV-IOMA>

For details about these adapters, see the Lenovo Press Product Guide *High IOPS SSD PCIe Adapters*, found at the following address:

<http://lenovopress.com/tips0729>

Power supplies

The server supports up to two redundant power supplies. Standard models come with one or two 900 W power supplies (model dependent; see Table 2). 1400 W AC and 750 W DC power supplies also available through CTO or Special Bid.

Installing a second power supply requires that the processor and memory expansion tray (88Y7365) or the power interposer card (88Y7367) be installed. The power interposer card option enables redundancy power support when the processor and memory expansion tray is not installed. If you do not have the processor and memory expansion tray installed and want to install two power supplies, then the power interposer card must be installed.

Table 17. Power supplies

Part number	Feature code	Description	Maximum supported	Models where used
44X4150	A54D	1400W HE Redundant Power Supply for altitudes >5000 meters	2	-
44X4152	A54E	1400W HE Redundant Power Supply	2	-
88Y7431	A2A7	900 W Power Supply	2	All models
88Y7433	A2EA	System x 4S- 750W High Efficiency -48 V DC Power Supply	2	-
88Y7367	A2A0	Power Interposer for Redundant Power Supply	1*	-

* The power interposer is not needed if the processor and memory expansion tray (88Y7365) is installed.

Each AC power supply ships standard with one 2.8 m C13 - C14 power cord.

Two installed power supplies form a redundant pair. Under extreme configurations, with two 1400 W supplies installed, it might still be possible to exceed 1400 W DC output. If this condition exists and a power supply fails, the server caps power at 1400 W until the second power supply is back online.

Integrated virtualization

The server supports VMware ESXi installed on a USB memory key. The key is installed in a USB socket inside the server. Table 17 lists the virtualization options.

Table 18. Virtualization options

Part number	Feature code	Description	Maximum supported
41Y8298	A2G0	Blank USB Memory Key for VMware ESXi Downloads	1

Download a supported VMware vSphere hypervisor image from <http://ibm.com/systems/x/os/vmware/> and load it on the memory key using the instructions provided.

Remote management

The server contains Integrated Management Module II (IMM2), which provides advanced service-processor control, monitoring, and alerting functions. If an environmental condition exceeds a threshold or if a system component fails, the IMM2 lights LEDs to help you diagnose the problem, records the error in the event log, and alerts you to the problem. A virtual presence capability also comes standard in this server for remote server management.

Remote server management is provided through industry-standard interfaces:

- Intelligent Platform Management Interface (IPMI) Version 2.0
- Simple Network Management Protocol (SNMP) Version 3
- Common Information Model (CIM)
- Web browser

The server also supports virtual media and remote control features, which provide the following functions:

- Remotely viewing video with graphics resolutions up to 1600x1200 at 75 Hz with up to 23 bits per pixel, regardless of the system state
- Remotely accessing the server using the keyboard and mouse from a remote client
- Mapping the CD or DVD drive, diskette drive, and USB flash drive on a remote client, and mapping ISO and diskette image files as virtual drives that are available for use by the server
- Uploading a diskette image to the IMM2 memory and mapping it to the server as a virtual drive
- Capturing blue-screen errors

Supported operating systems

The server supports the following operating systems:

- Microsoft Windows Server 2008 R2
- Microsoft Windows Server 2012
- Microsoft Windows Server 2012 R2
- Red Hat Enterprise Linux 6 Server x64 Edition
- Red Hat Enterprise Linux 7
- SUSE Enterprise Linux Server (SLES) 12
- SUSE LINUX Enterprise Server 11 for AMD64/EM64T
- SUSE LINUX Enterprise Server 11 with Xen for AMD64/EM64T
- VMware vSphere 5.0 (ESXi)
- VMware vSphere 5.5 (ESXi)

For the latest information about the specific versions and service levels supported and any other prerequisites, see the Operating System Interoperability Guide:

<http://lenovopress.com/osig>

Physical and electrical specifications

Dimensions and weight:

Width: 446 mm (17.5 in.)

Depth: 734 mm (28.9 in.)

Height: 87 mm (3.4 in.)

Approximate weight, fully configured: 31.1 kg (68.5 lb.)

Supported environment:

- Air temperature:
 - 5 - 40 °C (41 - 104 °F) at 0 - 3048 m (10,000 ft); ASHRAE A3 compliant
- Humidity: 8% - 80%
- Electrical:
 - 100 - 127 (nominal) V AC, 50 Hz or 60 Hz, and System 20 A (10 A per power supply)
 - 200 - 208 (nominal) V AC, 50 Hz or 60 Hz, and System 10 A
 - 200 - 240 (nominal) V AC, 50 Hz or 60 Hz, and System 9 A
 - Minimum configuration: 0.20 kVA (one power supply)
 - Minimum configuration: 0.26 kVA (two power supplies)
 - Typical configuration: 1.12 kVA (two power supplies)
 - Maximum configuration: 2.16 kVA (two power supplies)
- BTU output:
 - Minimum configuration: 648 BTU/hr (190 watts)
 - Maximum configuration: 7,336 BTU/hr (2150 watts)
- Noise level:
 - Idle: 6.5 bels
 - Operating: 6.6 bels

Warranty options

The System x3750 M4 has a three-year warranty with 24x7 standard call center support and 9x5 Next Business Day onsite coverage. Also available are Lenovo Services warranty maintenance upgrades and post-warranty maintenance agreements, with a well-defined scope of services, including service hours, response time, term of service, and service agreement terms and conditions.

Lenovo warranty service upgrade offerings are country-specific. Not all warranty service upgrades are available in every country. For more information about Lenovo warranty service upgrade offerings that are available in your country, visit the Lenovo Services website:

<https://www-304.ibm.com/sales/gss/download/spst/servicepac/extProductSelectorWWW.do>

The following table explains warranty service definitions in more detail.

Table 19. Warranty service definitions

Term	Description
On-site service	A service technician will arrive at the client's location for equipment service.
24x7x2 hour	A service technician is scheduled to arrive at the client's location within two hours after remote problem determination is completed. Lenovo provides service around the clock, every day, including Lenovo holidays.
24x7x4 hour	A service technician is scheduled to arrive at the client's location within four hours after remote problem determination is completed. Lenovo provides service around the clock, every day, including Lenovo holidays.
9x5x4 hour	A service technician is scheduled to arrive at the client's location within four business hours after remote problem determination is completed. Lenovo provides service 8:00 am - 5:00 pm in the client's local time zone, Monday-Friday, excluding Lenovo holidays. For example, if a customer reports an incident at 3:00 pm on Friday, the technician will arrive by 10:00 am the following Monday.
9x5 next business day	A service technician is scheduled to arrive at the client's location on the business day after remote problem determination is completed. Lenovo provides service 8:00 am - 5:00 pm in the client's local time zone, Monday - Friday, excluding Lenovo holidays. Calls received after 4:00 pm local time require an extra business day for service dispatch. Next business day service is not guaranteed.
Committed Repair	Problems receive priority handling so that repairs are completed within the committed time of 6, 8, or 24 hours. Lenovo provides service 24 hours/day, every day, including Lenovo holidays.

The following Lenovo warranty service upgrades are available:

- Warranty and maintenance service upgrades:
 - Three, four, or five years of 9x5 or 24x7 service coverage
 - Onsite response from next business day to 2 or 4 hours
 - Committed repair service
 - Warranty extension of up to 5 years
 - Post warranty extensions
- Committed Repair Service

Committed Repair Services enhances the level of Warranty Service Upgrade or Post Warranty/Maintenance Service offering associated with the selected systems. Offerings vary and are available in select countries.

 - Priority handling to meet defined time frames to restore the failing machine to good working condition
 - Committed repair service levels are measured within the following coverage hours:
 - 24x7x6: Service performed 24 hours per day, 7 days per week, within 6 hours
 - 24x7x8: Service performed 24 hours per day, 7 days per week, within 8 hours
 - 24x7x24: Service performed 24 hours per day, 7 days per week, within 24 hours
- Hard Drive Retention

Lenovo's Hard Drive Retention service is a multi-drive hard drive retention offering that ensures your data is always under your control, regardless of the number of hard drives that are installed in your Lenovo server. In the unlikely event of a hard drive failure, you retain possession of your hard drive while Lenovo replaces the failed drive part. Your data stays safely on your premises, in your hands. The Hard Drive Retention service can be purchased in convenient bundles with our warranty upgrades and extensions.
- Microcode Support

Keeping microcode current helps prevent hardware failures and security exposure. There are two levels of service: analysis of the installed base and analysis and update where required. Offerings vary by country and can be bundled with other warranty upgrades and extensions.

- Remote Technical Support Services (RTS)

RTS provides comprehensive technical call center support for covered servers, storage, operating systems, and applications. Providing a single source for support of hardware and software issues, RTS can reduce problem resolution time, decreasing the cost to address technical problems and increasing uptime. Offerings are available for Windows, Linux, IBM Systems Director, VMware, Microsoft business applications, and Lenovo System x storage devices, and IBM OEM storage devices.

Regulatory compliance

The server conforms to the following standards:

- ASHRAE A3
- FCC - Verified to comply with Part 15 of the FCC Rules, Class A
- Canada ICES-003, issue 4, Class A
- UL/IEC 60950-1
- CSA C22.2 No. 60950-1
- NOM-019
- Argentina IEC60950-1
- Japan VCCI, Class A
- Australia/New Zealand AS/NZS CISPR 22, Class A
- IEC 60950-1(CB Certificate and CB Test Report)
- China CCC (GB4943), GB9254 Class A, GB17625.1
- Taiwan BSMI CNS13438, Class A; CNS14336-1
- Korea KN22, Class A; KN24
- Russia/GOST ME01, IEC-60950-1, GOST R 51318.22, GOST R 51318.24, GOST R 51317.3.2, and GOST R 51317.3.3
- IEC 60950-1 (CB Certificate and CB Test Report)
- CE Mark (EN55022 Class A, EN60950-1, EN55024, EN61000-3-2, and EN61000-3-3)
- CISPR 22, Class A
- TUV-GS (EN60950-1 /IEC60950-1,EK1-ITB2000)
- RoHS compliance (Directive 2002/95/EC)

External drive enclosures

The server supports attachment to external drive enclosures using a RAID controller with external ports or a SAS host bus adapter. Adapters supported by the server are listed in the [SAS adapters for external storage](#) section.

The following table lists the 6 Gbps SAS external drive enclosures that are offered by Lenovo that can be used with the server for storage expansion.

Table 20. E1012 and E1024 external drive enclosure models

Part number	Description
64111B1	Lenovo Storage E1012 LFF Disk Expansion Single SAS IO Module, Rail Kit, 9x5 NBD
64111B2	Lenovo Storage E1012 LFF Disk Expansion Dual SAS IO Module, Rail Kit, 9x5 NBD
64111B3	Lenovo Storage E1024 SFF Disk Expansion Single SAS IO Module, Rail Kit, 9x5 NBD
64111B4	Lenovo Storage E1024 SFF Disk Expansion Dual SAS IO Module, Rail Kit, 9x5 NBD

For details about supported drives and cables for the Lenovo Storage E1012 and E1024, see the Lenovo Press Product Guide:

<http://lenovopress.com/lp0043>

The following table lists the 12 Gbps SAS external drive enclosures offered by Lenovo that can be used with the server for storage expansion.

Note: Information provided in this section is for ordering reference purposes only. For the operating system and adapter support details, refer to the interoperability matrix for a particular storage enclosure that can be found on the Lenovo Data Center Support web site:

<http://datacentersupport.lenovo.com>

Table 21. External drive enclosures

Description	Part number		
	Worldwide	Japan	PRC
Lenovo Storage D1212 LFF Disk Expansion with Dual SAS IO Modules	4587A11	4587A1J	4587A1C
Lenovo Storage D1224 SFF Disk Expansion with Dual SAS IO Modules	4587A31	4587A3J	4587A3C
Lenovo Storage D3284 4TB x 84 HD Expansion Enclosure	641311F		
Lenovo Storage D3284 6TB x 84 HD Expansion Enclosure	641312F		
Lenovo Storage D3284 8TB x 84 HD Expansion Enclosure	641313F		
Lenovo Storage D3284 10TB x 84 HD Expansion Enclosure	641314F		

For details about supported drives, adapters, and cables, see the following Lenovo Press Product Guides:

- Lenovo Storage D1212 and D1224
<http://lenovopress.com/lp0512>
- Lenovo Storage D3284
<http://lenovopress.com/lp0513>

External disk storage systems

Lenovo offers the ThinkSystem DE Series, ThinkSystem DG Series and ThinkSystem DM Series external storage systems for high-performance storage. See the DE Series, DG Series and DM Series product guides for specific controller models, expansion enclosures and configuration options:

- ThinkSystem DE Series Storage
<https://lenovopress.com/storage/thinksystem/de-series#rt=product-guide>
- ThinkSystem DM Series Storage
<https://lenovopress.com/storage/thinksystem/dm-series#rt=product-guide>
- ThinkSystem DG Series Storage
<https://lenovopress.com/storage/thinksystem/dg-series#rt=product-guide>

External backup units

The following table lists the external backup options that are offered by Lenovo.

Table 22. External backup options

Part number	Description
External RDX USB drives	
4T27A10725	ThinkSystem RDX External USB 3.0 Dock
External SAS tape backup drives	
6160S7E	IBM TS2270 Tape Drive Model H7S
6160S8E	IBM TS2280 Tape Drive Model H8S
6160S9E	IBM TS2290 Tape Drive Model H9S
External SAS tape backup autoloaders	
6171S7R	IBM TS2900 Tape Autoloader w/LTO7 HH SAS
6171S8R	IBM TS2900 Tape Autoloader w/LTO8 HH SAS
6171S9R	IBM TS2900 Tape Autoloader w/LTO9 HH SAS
External tape backup libraries	
6741A1F	IBM TS4300 3U Tape Library-Base Unit
6741A3F	IBM TS4300 3U Tape Library-Expansion Unit
Full High 8 Gb Fibre Channel for TS4300	
01KP938	LTO 7 FH Fibre Channel Drive
01KP954	LTO 8 FH Fibre Channel Drive
02JH837	LTO 9 FH Fibre Channel Drive
Half High 8 Gb Fibre Channel for TS4300	
01KP936	LTO 7 HH Fibre Channel Drive
01KP952	LTO 8 HH Fibre Channel Drive
02JH835	LTO 9 HH Fibre Channel Drive
Half High 6 Gb SAS for TS4300	
01KP937	LTO 7 HH SAS Drive
01KP953	LTO 8 HH SAS Drive
02JH836	LTO 9 HH SAS Drive

For more information, see the list of Product Guides in the Backup units category:
<https://lenovopress.com/servers/options/backup>

Top-of-rack Ethernet switches

The following table lists the Ethernet LAN switches that are offered by Lenovo.

Table 23. Ethernet LAN switches

Part number	Description
1 Gb Ethernet Rack switches	
7Y810011WW	Lenovo ThinkSystem NE0152T RackSwitch (Rear to Front)
7Z320011WW	Lenovo ThinkSystem NE0152TO RackSwitch (Rear to Front, ONIE)
7159BAX	Lenovo RackSwitch G7028 (Rear to Front)
7159CAX	Lenovo RackSwitch G7052 (Rear to Front)
7159G52	Lenovo RackSwitch G8052 (Rear to Front)
7165H1X	Juniper EX2300-C PoE Switch
7165H2X	Juniper EX2300-24p PoE Switch
1 Gb Ethernet Campus switches	
7Z340011WW	Lenovo CE0128TB Switch (3-Year Warranty)
7Z360011WW	Lenovo CE0128TB Switch (Limited Lifetime Warranty)
7Z340012WW	Lenovo CE0128PB Switch (3-Year Warranty)
7Z360012WW	Lenovo CE0128PB Switch (Limited Lifetime Warranty)
7Z350021WW	Lenovo CE0152TB Switch (3-Year Warranty)
7Z370021WW	Lenovo CE0152TB Switch (Limited Lifetime Warranty)
7Z350022WW	Lenovo CE0152PB Switch (3-Year Warranty)
7Z370022WW	Lenovo CE0152PB Switch (Limited Lifetime Warranty)
10 Gb Ethernet switches	
7159A1X	Lenovo ThinkSystem NE1032 RackSwitch (Rear to Front)
7159B1X	Lenovo ThinkSystem NE1032T RackSwitch (Rear to Front)
7Z330011WW	Lenovo ThinkSystem NE1064TO RackSwitch (Rear to Front, ONIE)
7159C1X	Lenovo ThinkSystem NE1072T RackSwitch (Rear to Front)
7159CRW	Lenovo RackSwitch G8272 (Rear to Front)
7159GR6	Lenovo RackSwitch G8296 (Rear to Front)
7159BR6	Lenovo RackSwitch G8124E (Rear to Front)
25 Gb Ethernet switches	
7159E1X	Lenovo ThinkSystem NE2572 RackSwitch (Rear to Front)
7Z210021WW	Lenovo ThinkSystem NE2572O RackSwitch (Rear to Front, ONIE)
7Z330021WW	Lenovo ThinkSystem NE2580O RackSwitch (Rear to Front, ONIE)
100 Gb Ethernet switches	
7159D1X	Lenovo ThinkSystem NE10032 RackSwitch (Rear to Front)
7Z210011WW	Lenovo ThinkSystem NE10032O RackSwitch (Rear to Front, ONIE)

For more information, see the list of Product Guides in the following switch categories:

- 1 Gb Ethernet switches: <http://lenovopress.com/networking/tor/1gb?rt=product-guide>
- 10 Gb Ethernet switches: <http://lenovopress.com/networking/tor/10gb?rt=product-guide>
- 25 Gb Ethernet switches: <http://lenovopress.com/networking/tor/25gb?rt=product-guide>
- 40 Gb Ethernet switches: <http://lenovopress.com/networking/tor/40gb?rt=product-guide>
- 100 Gb Ethernet switches: <https://lenovopress.com/networking/tor/100Gb?rt=product-guide>

Uninterruptible power supply units

The following table lists the uninterruptible power supply (UPS) units that are offered by Lenovo.

Table 24. Uninterruptible power supply units

Part number	Description
Rack-mounted or tower UPS units - 100-125VAC	
7DD5A001WW	RT1.5kVA 2U Rack or Tower UPS-G2 (100-125VAC)
55941AX	RT1.5kVA 2U Rack or Tower UPS (100-125VAC)
55942AX	RT2.2kVA 2U Rack or Tower UPS (100-125VAC)
7DD5A003WW	RT3kVA 2U Rack or Tower UPS-G2 (100-125VAC)
55943AX	RT3kVA 2U Rack or Tower UPS (100-125VAC)
Rack-mounted or tower UPS units - 200-240VAC	
7DD5A002WW	RT1.5kVA 2U Rack or Tower UPS-G2 (200-240VAC)
55941KX	RT1.5kVA 2U Rack or Tower UPS (200-240VAC)
55942KX	RT2.2kVA 2U Rack or Tower UPS (200-240VAC)
7DD5A005WW	RT3kVA 2U Rack or Tower UPS-G2 (200-240VAC)
55943KX	RT3kVA 2U Rack or Tower UPS (200-240VAC)
7DD5A007WW	RT5kVA 3U Rack or Tower UPS-G2 (200-240VAC)
55945KX	RT5kVA 3U Rack or Tower UPS (200-240VAC)
7DD5A008WW	RT6kVA 3U Rack or Tower UPS-G2 (200-240VAC)
55946KX	RT6kVA 3U Rack or Tower UPS (200-240VAC)
55948KX	RT8kVA 6U Rack or Tower UPS (200-240VAC)
7DD5A00AWW	RT11kVA 6U Rack or Tower UPS-G2 (200-240VAC)
55949KX	RT11kVA 6U Rack or Tower UPS (200-240VAC)
55943KT†	ThinkSystem RT3kVA 2U Standard UPS (200-230VAC) (2x C13 10A, 2x GB 10A, 1x C19 16A outlets)
55943LT†	ThinkSystem RT3kVA 2U Long Backup UPS (200-230VAC) (2x C13 10A, 2x GB 10A, 1x C19 16A outlets)
55946KT†	ThinkSystem RT6kVA 5U UPS (200-230VAC) (2x C13 10A outlets, 1x Terminal Block output)
5594XKT†	ThinkSystem RT10kVA 5U UPS (200-230VAC) (2x C13 10A outlets, 1x Terminal Block output)
Rack-mounted or tower UPS units - 380-415VAC	
55948PX	RT8kVA 6U 3:1 Phase Rack or Tower UPS (380-415VAC)
55949PX	RT11kVA 6U 3:1 Phase Rack or Tower UPS (380-415VAC)

† Only available in China and the Asia Pacific market.

For more information, see the list of Product Guides in the UPS category:

<https://lenovopress.com/servers/options/ups>

Power distribution units

The following table lists the power distribution units (PDUs) that are offered by Lenovo.

Table 25. Power distribution units

Part number	Feature code	Description	ANZ	ASEAN	Brazil	EET	MEA	RUCIS	WE	HTK	INDIA	JAPAN	LA	NA	PRC
0U Basic PDUs															
4PU7A93176	C0QH	0U 36 C13 and 6 C19 Basic 32A 1 Phase PDU v2	Y	Y	Y	Y	Y	Y	Y	Y	Y	N	Y	Y	Y
4PU7A93169	C0DA	0U 36 C13 and 6 C19 Basic 32A 1 Phase PDU	Y	Y	Y	Y	Y	Y	Y	Y	Y	N	Y	Y	Y
4PU7A93177	C0QJ	0U 24 C13/C15 and 24 C13/C15/C19 Basic 32A 3 Phase WYE PDU v2	Y	Y	Y	Y	Y	Y	Y	Y	Y	Y	Y	Y	Y
4PU7A93170	C0D9	0U 24 C13/C15 and 24 C13/C15/C19 Basic 32A 3 Phase WYE PDU	Y	Y	Y	Y	Y	Y	Y	Y	Y	N	Y	Y	Y
00YJ776	ATZY	0U 36 C13/6 C19 24A 1 Phase PDU	N	Y	Y	N	N	N	N	N	N	Y	Y	Y	N
00YJ779	ATZX	0U 21 C13/12 C19 48A 3 Phase PDU	N	N	Y	N	N	N	Y	N	N	Y	Y	Y	N
00YJ777	ATZZ	0U 36 C13/6 C19 32A 1 Phase PDU	Y	Y	Y	Y	Y	Y	Y	Y	Y	N	N	Y	Y
00YJ778	AU00	0U 21 C13/12 C19 32A 3 Phase PDU	Y	Y	N	Y	Y	Y	Y	Y	Y	N	N	Y	Y
0U Switched and Monitored PDUs															
4PU7A93181	C0QN	0U 21 C13/C15 and 21 C13/C15/C19 Switched and Monitored 48A 3 Phase Delta PDU v2 (60A derated)	N	Y	N	N	N	N	N	Y	N	Y	N	Y	N
4PU7A93174	C0D5	0U 21 C13/C15 and 21 C13/C15/C19 Switched and Monitored 48A 3 Phase Delta PDU (60A derated)	N	Y	N	N	N	N	N	Y	N	N	N	Y	N
4PU7A93178	C0QK	0U 20 C13 and 4 C19 Switched and Monitored 32A 1 Phase PDU v2	Y	Y	Y	Y	Y	Y	Y	Y	Y	N	Y	Y	Y
4PU7A93171	C0D8	0U 20 C13 and 4 C19 Switched and Monitored 32A 1 Phase PDU	Y	Y	Y	Y	Y	Y	Y	Y	Y	N	Y	Y	Y
4PU7A93182	C0QP	0U 18 C13/C15 and 18 C13/C15/C19 Switched and Monitored 63A 3 Phase WYE PDU v2	Y	Y	Y	Y	Y	Y	Y	Y	Y	Y	Y	Y	Y
4PU7A93175	C0CS	0U 18 C13/C15 and 18 C13/C15/C19 Switched and Monitored 63A 3 Phase WYE PDU	Y	Y	Y	Y	Y	Y	Y	Y	Y	N	Y	Y	Y
4PU7A93180	C0QM	0U 18 C13/C15 and 18 C13/C15/C19 Switched and Monitored 32A 3 Phase WYE PDU v2	Y	Y	Y	Y	Y	Y	Y	Y	Y	Y	Y	Y	Y
4PU7A93173	C0D6	0U 18 C13/C15 and 18 C13/C15/C19 Switched and Monitored 32A 3 Phase WYE PDU	Y	Y	Y	Y	Y	Y	Y	Y	Y	N	Y	Y	Y
4PU7A93179	C0QL	0U 16 C13/C15 and 16 C13/C15/C19 Switched and Monitored 24A 1 Phase PDU v2 (30A derated)	N	Y	N	N	N	N	N	Y	N	Y	N	Y	N
4PU7A93172	C0D7	0U 16 C13/C15 and 16 C13/C15/C19 Switched and Monitored 24A 1 Phase PDU(30A derated)	N	Y	N	N	N	N	N	Y	N	N	N	Y	N
00YJ783	AU04	0U 12 C13/12 C19 Switched and Monitored 48A 3 Phase PDU	N	N	Y	N	N	N	Y	N	N	Y	Y	Y	N
00YJ781	AU03	0U 20 C13/4 C19 Switched and Monitored 24A 1 Phase PDU	N	N	Y	N	Y	N	Y	N	N	Y	Y	Y	N
00YJ782	AU02	0U 18 C13/6 C19 Switched and Monitored 32A 3 Phase PDU	Y	Y	Y	Y	Y	Y	Y	Y	Y	N	Y	N	Y
00YJ780	AU01	0U 20 C13/4 C19 Switched and Monitored 32A 1 Phase PDU	Y	Y	Y	Y	Y	Y	Y	Y	Y	N	Y	N	Y
1U Switched and Monitored PDUs															

Part number	Feature code	Description	ANZ	ASEAN	Brazil	EET	MEA	RUCIS	WE	HTK	INDIA	JAPAN	LA	NA	PRC
4PU7A90808	C0D4	1U 18 C19/C13 Switched and monitored 48A 3P WYE PDU V2 ETL	N	N	N	N	N	N	N	Y	N	Y	Y	Y	N
4PU7A81117	BNDV	1U 18 C19/C13 switched and monitored 48A 3P WYE PDU - ETL	N	N	N	N	N	N	N	N	N	N	N	Y	N
4PU7A90809	C0DE	1U 18 C19/C13 Switched and monitored 48A 3P WYE PDU V2 CE	Y	Y	Y	Y	Y	Y	Y	Y	Y	Y	Y	N	Y
4PU7A81118	BNDW	1U 18 C19/C13 switched and monitored 48A 3P WYE PDU – CE	Y	Y	Y	Y	Y	Y	Y	Y	Y	Y	Y	N	Y
4PU7A90810	C0DD	1U 18 C19/C13 Switched and monitored 80A 3P Delta PDU V2	N	N	N	N	N	N	N	Y	N	Y	Y	Y	N
4PU7A77467	BLC4	1U 18 C19/C13 Switched and Monitored 80A 3P Delta PDU	N	N	N	N	N	N	N	N	N	Y	N	Y	N
4PU7A90811	C0DC	1U 12 C19/C13 Switched and monitored 32A 3P WYE PDU V2	Y	Y	Y	Y	Y	Y	Y	Y	Y	Y	Y	Y	Y
4PU7A77468	BLC5	1U 12 C19/C13 switched and monitored 32A 3P WYE PDU	Y	Y	Y	Y	Y	Y	Y	Y	Y	Y	Y	Y	Y
4PU7A90812	C0DB	1U 12 C19/C13 Switched and monitored 60A 3P Delta PDU V2	N	N	N	N	N	N	N	Y	N	Y	Y	Y	N
4PU7A77469	BLC6	1U 12 C19/C13 switched and monitored 60A 3P Delta PDU	N	N	N	N	N	N	N	N	N	N	N	Y	N
46M4002	5896	1U 9 C19/3 C13 Switched and Monitored DPI PDU	Y	Y	Y	Y	Y	Y	Y	Y	Y	Y	Y	Y	Y
46M4004	5894	1U 12 C13 Switched and Monitored DPI PDU	Y	Y	Y	Y	Y	Y	Y	Y	Y	Y	Y	Y	Y
46M4003	5897	1U 9 C19/3 C13 Switched and Monitored 60A 3 Phase PDU	Y	Y	Y	Y	Y	Y	Y	Y	Y	Y	Y	Y	Y
46M4005	5895	1U 12 C13 Switched and Monitored 60A 3 Phase PDU	Y	Y	Y	Y	Y	Y	Y	Y	Y	Y	Y	Y	Y
1U Ultra Density Enterprise PDUs (9x IEC 320 C13 + 3x IEC 320 C19 outlets)															
71763NU	6051	Ultra Density Enterprise C19/C13 PDU 60A/208V/3PH	N	N	Y	N	N	N	N	N	N	Y	Y	Y	N
71762NX	6091	Ultra Density Enterprise C19/C13 PDU Module	Y	Y	Y	Y	Y	Y	Y	Y	Y	Y	Y	Y	Y
1U C13 Enterprise PDUs (12x IEC 320 C13 outlets)															
39M2816	6030	DPI C13 PDU+	Y	Y	Y	Y	Y	Y	Y	Y	Y	Y	Y	Y	Y
39Y8941	6010	Enterprise C13 PDU	Y	Y	Y	Y	Y	Y	Y	Y	Y	Y	Y	Y	Y
1U C19 Enterprise PDUs (6x IEC 320 C19 outlets)															
39Y8948	6060	Enterprise C19 PDU	Y	Y	Y	Y	Y	Y	Y	Y	Y	Y	Y	Y	Y
39Y8923	6061	Enterprise C19 3 phase PDU (60a)	N	N	Y	N	N	N	Y	N	N	N	Y	Y	N
1U Front-end PDUs (3x IEC 320 C19 outlets)															
39Y8938	6002	DPI 30amp/125V Front-end PDU with NEMA L5-30P	Y	Y	Y	Y	Y	Y	Y	Y	Y	Y	Y	Y	Y
39Y8939	6003	DPI 30amp/250V Front-end PDU with NEMA L6-30P	Y	Y	Y	Y	Y	Y	Y	Y	Y	Y	Y	Y	Y
39Y8934	6005	DPI 32amp/250V Front-end PDU with IEC 309 2P+Gnd	Y	Y	Y	Y	Y	Y	Y	Y	Y	Y	Y	Y	Y
39Y8940	6004	DPI 60amp/250V Front-end PDU with IEC 309 2P+Gnd connector	Y	N	Y	Y	Y	Y	Y	N	N	Y	Y	Y	N

Part number	Feature code	Description	ANZ	ASEAN	Brazil	EET	MEA	RUCIS	WE	HTK	INDIA	JAPAN	LA	NA	PRC
39Y8935	6006	DPI 63amp/250V Front-end PDU with IEC 309 2P+Gnd connector	Y	Y	Y	Y	Y	Y	Y	Y	Y	Y	Y	Y	Y
1U NEMA PDUs (6x NEMA 5-15R outlets)															
39Y8905	5900	DPI 100-127v PDU with Fixed Nema L5-15P line cord	Y	Y	Y	Y	Y	Y	Y	Y	Y	Y	Y	Y	Y
Line cords for 1U PDUs that ship without a line cord															
40K9611	6504	DPI 32a Cord (IEC 309 3P+N+G)	Y	Y	Y	Y	Y	Y	Y	Y	Y	Y	Y	Y	Y
40K9612	6502	DPI 32a Cord (IEC 309 P+N+G)	Y	Y	Y	Y	Y	Y	Y	Y	Y	Y	Y	Y	Y
40K9613	6503	DPI 63a Cord (IEC 309 P+N+G)	Y	Y	Y	Y	Y	Y	Y	Y	Y	Y	Y	Y	Y
40K9614	6500	DPI 30a Cord (NEMA L6-30P)	Y	Y	Y	Y	Y	Y	Y	Y	Y	Y	Y	Y	Y
40K9615	6501	DPI 60a Cord (IEC 309 2P+G)	N	N	Y	N	N	N	Y	N	N	Y	Y	Y	N
40K9617	6505	4.3m, 32A/230V, Souriau UTG to AS/NZS 3112 (Aus/NZ) Line Cord	Y	Y	Y	Y	Y	Y	Y	Y	Y	Y	Y	Y	Y
40K9618	6506	4.3m, 32A/250V, Souriau UTG Female to KSC 8305 (S. Korea) Line Cord	Y	Y	Y	Y	Y	Y	Y	Y	Y	Y	Y	Y	Y

For more information, see the Lenovo Press documents in the PDU category:
<https://lenovopress.com/servers/options/pdu>

Rack cabinets

The server supports the rack cabinets listed in the following table.

Table 26. Rack cabinets

Part number	Description
93072PX	25U Static S2 Standard Rack
93072RX	25U Standard Rack
93074RX	42U Standard Rack
93074XX	42U Standard Rack Extension
93084EX	42U Enterprise Expansion Rack
93084PX	42U Enterprise Rack
93604EX	42U 1200 mm Deep Dynamic Expansion Rack
93604PX	42U 1200 mm Deep Dynamic Rack
93614EX	42U 1200 mm Deep Static Expansion Rack
93614PX	42U 1200 mm Deep Static Rack
93624EX	47U 1200 mm Deep Static Expansion Rack
93624PX	47U 1200 mm Deep Static Rack
99564RX	S2 42U Dynamic Standard Rack
99564XX	S2 42U Dynamic Standard Expansion Rack

For more information, see the list of Lenovo Press Product Guides in the Rack cabinets and options category:
<http://lenovopress.com/systemx/rack>

KVM console options

The following table lists the supported KVM consoles, keyboards, and KVM switches.

Table 27. Console keyboards

Part number	Description
Consoles	
17238BX	1U 18.5" Standard Console (without keyboard)
Console keyboards	
00MW310	Lenovo UltraNav Keyboard USB - US Eng
46W6713	Keyboard w/ Int. Pointing Device USB - Arabic 253 RoHS v2
46W6714	Keyboard w/ Int. Pointing Device USB - Belg/UK 120 RoHS v2
46W6715	Keyboard w/ Int. Pointing Device USB - Chinese/US 467 RoHS v2
46W6716	Keyboard w/ Int. Pointing Device USB - Czech 489 RoHS v2
46W6717	Keyboard w/ Int. Pointing Device USB - Danish 159 RoHS v2
46W6718	Keyboard w/ Int. Pointing Device USB - Dutch 143 RoHS v2
46W6719	Keyboard w/ Int. Pointing Device USB - French 189 RoHS v2
46W6720	Keyboard w/ Int. Pointing Device USB - Fr/Canada 445 RoHS v2
46W6721	Keyboard w/ Int. Pointing Device USB - German 129 RoHS v2
46W6722	Keyboard w/ Int. Pointing Device USB - Greek 219 RoHS v2
46W6723	Keyboard w/ Int. Pointing Device USB - Hebrew 212 RoHS v2
46W6724	Keyboard w/ Int. Pointing Device USB - Hungarian 208 RoHS v2
46W6725	Keyboard w/ Int. Pointing Device USB - Italian 141 RoHS v2
46W6726	Keyboard w/ Int. Pointing Device USB - Japanese 194 RoHS v2
46W6727	Keyboard w/ Int. Pointing Device USB - Korean 413 RoHS v2
46W6728	Keyboard w/ Int. Pointing Device USB - LA Span 171 RoHS v2
46W6729	Keyboard w/ Int. Pointing Device USB - Norwegian 155 RoHS v2
46W6730	Keyboard w/ Int. Pointing Device USB - Polish 214 RoHS v2
46W6731	Keyboard w/ Int. Pointing Device USB - Portuguese 163 RoHS v2
46W6732	Keyboard w/ Int. Pointing Device USB - Russian 441 RoHS v2
46W6733	Keyboard w/ Int. Pointing Device USB - Slovak 245 RoHS v2
46W6734	Keyboard w/ Int. Pointing Device USB - Spanish 172 RoHS v2
46W6735	Keyboard w/ Int. Pointing Device USB - Swed/Finn 153 RoHS v2
46W6736	Keyboard w/ Int. Pointing Device USB - Swiss F/G 150 RoHS v2
46W6737	Keyboard w/ Int. Pointing Device USB - Thai 191 RoHS v2
46W6738	Keyboard w/ Int. Pointing Device USB - Turkish 179 RoHS v2
46W6739	Keyboard w/ Int. Pointing Device USB - UK Eng 166 RoHS v2
46W6740	Keyboard w/ Int. Pointing Device USB - US Euro 103P RoHS v2
46W6741	Keyboard w/ Int. Pointing Device USB - Slovenian 234 RoHS v2
Console switches	
1754D2X	Global 4x2x32 Console Manager (GCM32)
1754D1X	Global 2x2x16 Console Manager (GCM16)
1754A2X	Local 2x16 Console Manager (LCM16)
1754A1X	Local 1x8 Console Manager (LCM8)
Console switch cables	

Part number	Description
43V6147	Single Cable USB Conversion Option (UCO)
39M2895	USB Conversion Option (4 Pack UCO)
46M5383	Virtual Media Conversion Option Gen2 (VCO2)
46M5382	Serial Conversion Option (SCO)

For more information, see the list of Product Guides in the KVM Switches and Consoles category:
<http://lenovopress.com/servers/options/kvm>

Lenovo Financial Services

Why wait to obtain the technology you need now? No payments for 90 days and predictable, low monthly payments make it easy to budget for your Lenovo solution.

- **Flexible**

Our in-depth knowledge of the products, services and various market segments allows us to offer greater flexibility in structures, documentation and end of lease options.

- **100% Solution Financing**

Financing your entire solution including hardware, software, and services, ensures more predictability in your project planning with fixed, manageable payments and low monthly payments.

- **Device as a Service (DaaS)**

Leverage latest technology to advance your business. Customized solutions aligned to your needs. Flexibility to add equipment to support growth. Protect your technology with Lenovo's Premier Support service.

- **24/7 Asset management**

Manage your financed solutions with electronic access to your lease documents, payment histories, invoices and asset information.

- **Fair Market Value (FMV) and \$1 Purchase Option Leases**

Maximize your purchasing power with our lowest cost option. An FMV lease offers lower monthly payments than loans or lease-to-own financing. Think of an FMV lease as a rental. You have the flexibility at the end of the lease term to return the equipment, continue leasing it, or purchase it for the fair market value. In a \$1 Out Purchase Option lease, you own the equipment. It is a good option when you are confident you will use the equipment for an extended period beyond the finance term. Both lease types have merits depending on your needs. We can help you determine which option will best meet your technological and budgetary goals.

Ask your Lenovo Financial Services representative about this promotion and how to submit a credit application. For the majority of credit applicants, we have enough information to deliver an instant decision and send a notification within minutes.

Related publications and links

- US Announcement Letter
<http://ibm.com/common/ssi/cgi-bin/ssialias?infotype=dd&subtype=ca&&htmlfid=897/ENUS114-037>
- System x3750 M4 product page:
<http://www.ibm.com/systems/x/hardware/rack/x3750m4/index.html>
- *System x3750 M4 Installation and Service Guide* :
<http://ibm.com/support/entry/portal/docdisplay?Indocid=MIGR-5090828>
- *Integrated Management Module II User's Guide*
<http://ibm.com/support/entry/portal/docdisplay?Indocid=MIGR-5086346>
- xREF: System x Reference:
<http://lenovopress.com/xref>
- System x Support Portal:
<http://ibm.com/support/entry/portal/>
http://ibm.com/support/entry/portal/Downloads/Hardware/Systems/System_x/System_x3750_M4

Related product families

Product families related to this document are the following:

- [4-Socket Rack Servers](#)

Notices

Lenovo may not offer the products, services, or features discussed in this document in all countries. Consult your local Lenovo representative for information on the products and services currently available in your area. Any reference to a Lenovo product, program, or service is not intended to state or imply that only that Lenovo product, program, or service may be used. Any functionally equivalent product, program, or service that does not infringe any Lenovo intellectual property right may be used instead. However, it is the user's responsibility to evaluate and verify the operation of any other product, program, or service. Lenovo may have patents or pending patent applications covering subject matter described in this document. The furnishing of this document does not give you any license to these patents. You can send license inquiries, in writing, to:

Lenovo (United States), Inc.
8001 Development Drive
Morrisville, NC 27560
U.S.A.
Attention: Lenovo Director of Licensing

LENOVO PROVIDES THIS PUBLICATION "AS IS" WITHOUT WARRANTY OF ANY KIND, EITHER EXPRESS OR IMPLIED, INCLUDING, BUT NOT LIMITED TO, THE IMPLIED WARRANTIES OF NON-INFRINGEMENT, MERCHANTABILITY OR FITNESS FOR A PARTICULAR PURPOSE. Some jurisdictions do not allow disclaimer of express or implied warranties in certain transactions, therefore, this statement may not apply to you.

This information could include technical inaccuracies or typographical errors. Changes are periodically made to the information herein; these changes will be incorporated in new editions of the publication. Lenovo may make improvements and/or changes in the product(s) and/or the program(s) described in this publication at any time without notice.

The products described in this document are not intended for use in implantation or other life support applications where malfunction may result in injury or death to persons. The information contained in this document does not affect or change Lenovo product specifications or warranties. Nothing in this document shall operate as an express or implied license or indemnity under the intellectual property rights of Lenovo or third parties. All information contained in this document was obtained in specific environments and is presented as an illustration. The result obtained in other operating environments may vary. Lenovo may use or distribute any of the information you supply in any way it believes appropriate without incurring any obligation to you.

Any references in this publication to non-Lenovo Web sites are provided for convenience only and do not in any manner serve as an endorsement of those Web sites. The materials at those Web sites are not part of the materials for this Lenovo product, and use of those Web sites is at your own risk. Any performance data contained herein was determined in a controlled environment. Therefore, the result obtained in other operating environments may vary significantly. Some measurements may have been made on development-level systems and there is no guarantee that these measurements will be the same on generally available systems. Furthermore, some measurements may have been estimated through extrapolation. Actual results may vary. Users of this document should verify the applicable data for their specific environment.

© Copyright Lenovo 2025. All rights reserved.

This document, TIPS1159, was created or updated on June 8, 2015.

Send us your comments in one of the following ways:

- Use the online Contact us review form found at:
<https://lenovopress.lenovo.com/TIPS1159>
- Send your comments in an e-mail to:
comments@lenovopress.com

This document is available online at <https://lenovopress.lenovo.com/TIPS1159>.

Trademarks

Lenovo and the Lenovo logo are trademarks or registered trademarks of Lenovo in the United States, other countries, or both. A current list of Lenovo trademarks is available on the Web at <https://www.lenovo.com/us/en/legal/copytrade/>.

The following terms are trademarks of Lenovo in the United States, other countries, or both:

Lenovo®

System x®

ThinkSystem®

UltraNav®

The following terms are trademarks of other companies:

Onload™ and Solarflare™ are trademarks of Advanced Micro Devices, Inc.

Intel® and Xeon® are trademarks of Intel Corporation or its subsidiaries.

Linux® is the trademark of Linus Torvalds in the U.S. and other countries.

Microsoft®, Windows Server®, and Windows® are trademarks of Microsoft Corporation in the United States, other countries, or both.

IBM®, Interconnect®, ServicePac®, and ibm.com® are trademarks of IBM in the United States, other countries, or both.

Other company, product, or service names may be trademarks or service marks of others.